

Agriculture Studies

Class Six



NATIONAL CURRICULUM AND TEXTBOOK BOARD, BANGLADESH

**Prescribed by the National Curriculum and Textbook Board
as a Textbook for class six from the academic year-2013.**

Agriculture Studies

Class Six

Written by

Prof. Muhammad Ashrafuzzaman
Prof. Mohammad Hossain Bhuiyan
Prof. Dr. Md. Anwarul Haque Beg
Dr. Kazi Ahsan Habib
Anwara Khanum
Kh. Zulfikar Hossain
A.K.M. Mizanur Rahman

Edited by

Prof. Dr. Md. Sadrul Amin

Translated by

Md. Alauddin PK. Ph. D
Subhash Chandra Sarkar

Published by
National Curriculum and Textbook Board
69-70, Motijheel Commercial Area, Dhaka-1000

[All rights reserved by the publisher]

First Publication : December, 2012

Revised Edition : September, 2014

Reprint : August, 2019

Design

National Curriculum and Textbook Board, Bangladesh

For free distribution by the Government of the People's Republic of Bangladesh
Printed by :

Preface

The aim of secondary education is to make the learners fit for entry into higher education by flourishing their latent talents and prospects with a view to building the nation with the spirit of the Language Movement and the Liberation War. To make the learners skilled and competent citizens of the country based on the economic, social, cultural and environmental settings is also an important issue of secondary education.

The textbooks of secondary level have been written and compiled according to the revised curriculum 2012 in accordance with the aims and objectives of National Education Policy-2010. Contents and presentations of the textbooks have been selected according to the moral and humanistic values of Bengali tradition and culture and the spirit of Liberation War 1971 ensuring equal dignity for all irrespective of caste and creed of different religions and sex.

The present government is committed to ensure the successful implementation of Vision 2021. Honorable Prime Minister, Government of the People's Republic of Bangladesh, Sheikh Hasina expressed her firm determination to make the country free from illiteracy and instructed the concerned authority to give free textbooks to every student of the country. National Curriculum and Textbook Board started to distribute textbooks free of cost since 2010 according to her instruction.

Bangladesh is basically an agro based country. Keeping the challenge of 21st century ahead in mind this textbook has been developed to introduce a technique to build up modern agricultural system by capitalizing agricultural science and information technology, the best utilization of limited land, implementation of appropriate technology to bring out the highest amount of crops. It is expected that this textbook will develop students competency on both theoretical and applied agriculture as to help keeping positive role in socio-economic development.

I thank sincerely all for their intellectual labor who were involved in the process of revision, writing, editing, art and design of the textbook.

Prof. Narayan Chandra Saha

Chairman

National Curriculum and Textbook Board, Bangladesh

Contents

Chapter	Title	Page
One	Agriculture in our life	1-9
Two	Agricultural Technology and Equipments	10-28
Three	Agricultural Inputs	29-46
Four	Agriculture and Climate	47-59
Five	Agricultural Production	60-91
Six	Afforestation	92-112

Chapter One

Agriculture in our life

Bangladesh is an agricultural country. Agriculture is very important in our life. Agriculture produces and supplies almost all inputs of basic needs of our everyday life. Moreover agriculture supplies money, necessary for purchasing other commodities and services. Agriculture plays a vital role in our life to fulfill the requirements of food, clothes, shelter and health. The areas of agriculture cover crops, animals and birds, fisheries and forestry.



Figure : Field crop

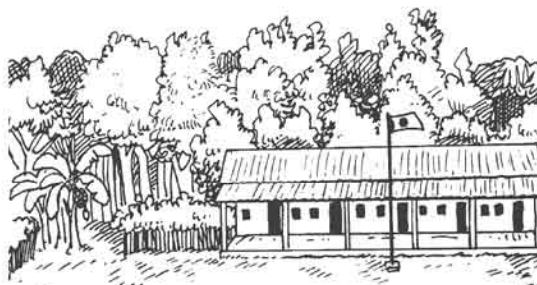

Figure : Social afforestation (School)

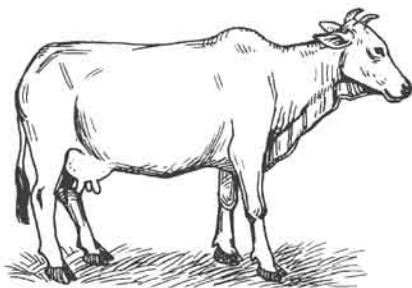

Figure : Cow

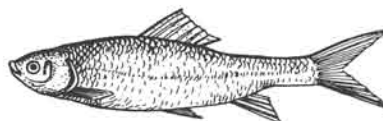

Figure : Rui fish

At the end of this chapter, we will be able to-

- explain areas and sectors of agriculture in Bangladesh.
- identify agriculture-related information and service providing sources.

Lesson-1: Areas and Sectors of Agriculture

Agriculture is old, yet modern and a very much honourable profession. Because through this, the basic needs of human beings are fulfilled. Basic needs of human beings mean food, clothes, shelter, health and education. So the agricultural sector is conveniently wide. Agriculture related subjects are crop production, livestock rearing, poultry rearing, fish culture and afforestation. Agriculture supplies us food. Rice, wheat, potato, maize, vegetables, fruits are foods that give us nutrition. We get fibers for cloth from jute, cotton and silk. We get house making materials and furniture from wood, bamboo, straw, thatching grass, big leaves etc. Bamboo, straw, cowdung, branches of trees, etc. are used as firewood. We get paper from wood, sugarcane trash, bamboo etc. We get medicine from amlaki, haritaki, triphala, patharchata leaves and vasoka. We also get milk, meat, egg, and nutrition from domestic animals and birds. These all are agriculture. Farmers produce food and supply clothing and building materials. The overall development of agro-based Bangladesh depends on agriculture. So there will be economic development, if we can ensure development in agriculture.

These basic needs are fulfilled through different types of crop production, animal and bird rearing, fish culture and afforestation. Different types of crops mean field crops, grains, oil, fiber, drinks, pulses and horticultural crops. Livestock rearing means rearing cattle in healthy condition, poultry rearing and production of cattle feed. Fish culture means different kinds of fish cultivation in closed and open water. And afforestation means natural afforestation, social afforestation and agriculture afforestation.



Figure : Rice field



Figure : Jute field



Figure : Wheat field

Task : Identify the areas of agricultural sector on the basis of the daily food taken by a family.

Lesson-2 : Crop production, Fisheries, Animals, Birds and Afforestation

We have discussed the areas of agriculture in the previous lesson. In that lesson we have known which things are included in agriculture. As a result, now we will discuss in details, the importance of crop production, fisheries, animals, birds and afforestation.

a) Crop production : Crop production is the principal matter of agricultural activities. People's livelihood i.e. fulfilling their need of food and clothing is closely related to crop production. On the basis of cultivation, crops are mainly classified into two groups-field crops and horticultural crops.



Figure : A basket of fruits

(i) Field crops: Paddy, wheat, maize, jute, cotton, etc. are field crops. Paddy, wheat and maize are cereals. Cereals are staple food for human beings. Cereals provide carbohydrate to our body. Pulse crops like lentil, mung bean, black gram, etc. supply protein. Sesame, mustard, lin seed sunflower, etc. fall under oil crops. These crops provide fat to our body. Jute is a fibre crop. It is our main crop. Beverages include tea, coffee, etc.

(ii) Horticultural crops : Farmers produce horticultural crops all the year round. Different kinds of vegetables, fruits, flowers, spices, etc. are related to horticultural crops. Gourd, bean, cauliflower, cabbage, tomato, potato, etc. are winter vegetables. Ash gourd, snake gourd, aroids, pointed gourd, bitter gourd, etc. are vegetables of the summer and rainy seasons. Mango, jack fruit, litchi, blackberry, etc. are seasonal fruits. Papaya, coconut, banana, etc. are found all the year round. We receive vitamins and mineral from vegetables and fruits. So, it can be said that we receive almost all nutrients we need through producing crops.

b) Fisheries : Fish is our silvery resource and principal source of protein. We receive the main part (60%) of animal protein from fish. Fish is our favourite food. So people say, Bangladeshes depend on fish and rice. The soil and water of Bangladesh are suitable for fish culture. Rui, katla, mrigel, shrimp, thai, pangas, silver carp, grass carp, sorputi, tilapia, etc. are the main cultivable fishes of the country. Many species of fish including shrimp are exported to foreign countries from Bangladesh. Different education and research institutions have invented many technologies of fish culture. Production of fish has increased because of the expansion of these technologies. At present

per person daily demand of fish is about 56 gm. But we receive about 52 gm per person daily.

c) Animals and Birds : Rearing animals and birds has occupied a major part of agricultural activities. Crop production and nutritional sides cannot be imagined without animals and birds. Cows, buffaloes, goats, sheep, etc are remarkable among the domestic animals. Among these, cows and buffaloes are used for ploughing and as beast of burden. Now mechanical power has occupied the place of animals, but in our country the necessity of animal power is not ended till today. Farmers are using cattle widely for ploughing. Cattle carts are used in villages for carrying goods. We are getting milk and meat by rearing cows, buffaloes, goats and sheep. On the other hand, from rearing poultry, pigeons, sand-piper etc. we are getting meat and eggs.

d) Forest and afforestation : An area which is covered with trees is called a forest. The method by which a forest is created is called afforestation. We know animals and plants are closely connected. Plants release oxygen and take carbon-di-oxide. Again animals release carbon-di-oxide and take oxygen. So for the survival of animals, plants need to be preserved. A country should have 25% of the total area covered with forest to maintain the ecological balance of that country. Different kinds of birds, animals and insects live in the forest. It fulfills the demand of wood and fuel and the environment also remains good.

Task : Prepare a list of horticultural crops, fish, animals and birds and trees of forests of your area in the agricultural sector.

New words: cereal, fibre crop, horticultural crop, field crop.

Lesson-3 : Agriculture-related necessary information and sources of getting services

Information on agricultural matters and services are given to farmers by an experienced farmers Agriculture Extension Officers and staff of Directorate of Agriculture, Directorate of Livestock and Directorate of Fisheries. Responsibilities of the respective officials and persons are discussed below:

a) Experienced farmers : An experienced farmer is a local leader and an adviser. He spontaneously keeps connection with local agriculture extension officers and enquires about new technologies. Moreover he collects information from mass-media. As a result, he becomes familiar as a local storehouse of information. When the extension officers visit an area, they seek the help of an experienced farmer and visits farmers' houses and farms

with him and sometimes sit at meetings at farmers' courtyard. Thus experienced farmers can increase their agricultural knowledge. Then they give advice to local farmers on agricultural matters.

Farmers suffer from many problems regarding crops e.g crop diseases, attack of insects, flood, drought, etc. For facing an unfavorable situation, farmers primarily seek the advice of an experienced farmer and he also sincerely gives advice to the primarily farmers as far as he knows.



Figure: Farmers meeting

b) Agriculture related directorates : Extension Officers of Directorate of Agriculture Extension, Directorate of Livestock, Directorate of Fisheries provide information and services from their own positions. They prepare posters, leaflets, booklets on specific technology and distribute among the farmers. Again agriculture information is circulated through radio and television. To circulate agricultural information, there is an organization named 'Agriculture Information Service'. Extension workers visit farmers' houses and farms. They conduct meetings with the farmers, demonstrate new technology or procedures and show the results of using new technology. They organize agricultural fairs and training for the farmers. The most attractive thing is that farmers identify their problems and solve some of them by themselves. The problems that cannot be solved are advised by the extension workers. Additionally farmers' field school has been established through the Directorate of Agricultural Extension. The farmers are being trained on integrated crop management through this school.

c) Local Agriculture Office : To give services to the farmers in each upazilla of Bangladesh, there is an agriculture office, a livestock office and a fishery office. These offices are operated by skilled agriculturists. Grassroot level official employees hold meetings with farmers. In the meetings farmers' problems are discussed and solutions are given.

d) Agricultural Fair : Modern agricultural technology, agricultural tools and produced agricultural products can be seen only through agriculture fairs. It is very important to organise such fairs in the cities as well as villages. It is possible to see at a glance the yield of

various crops in the fair. Seedlings, seed, fertilizers, agricultural technology equipments, etc. are displayed and sold in the fair. Agriculture related different leaflets, books, bulletins, magazines are also displayed in this fair and are distributed free among visitors. As a result, people who are involved in agricultural activities as well as those who are not involved are inspired in agricultural activities. So to get agricultural information there is no alternative to the agricultural fairs.



Figure : Agricultural Fair

Task: Discuss in groups and write about ‘agricultural information and sources of receiving services in your area’.

Lesson-4 : Agricultural Education and Research Institutions

a) Agricultural Education: Agricultural Education has been given at different levels of education system in Bangladesh for a long time in secondary schools. Agricultural education has been attached to Higher Secondary and Madrasha education. Dropped out learners use acquired knowledge in agricultural activities. There are 16 public and 154 private agricultural training institutes in Bangladesh.

Besides there are private Agricultural Training Institute (ATIs). The ATIs offer 4 year Agriculture Diploma under the academic control of Technical Education Board. There are 5 government agricultural universities for higher agricultural education. Agriculture Faculty is operated at two Science and Technology universities. Besides, there are agriculture faculties at Khulna and Rajshahi Universities. Graduation and post graduation degrees are offered from Agricultural Universities and faculty of agriculture.

b) Agriculture Research Institute : There are so many agricultural research institutes in Bangladesh. Most of the research institutes conduct researches on specific crops. Bangladesh Rice Research Institute researches on improved rice varieties and related technology for innovation. Bangladesh Jute Research Institute does all types of research for



Figure: Research institute

jute development. Bangladesh Sugarcane Research Institute does all types of research for sugarcane development. Bangladesh Agricultural Research Institute and Bangladesh Institute of Nuclear Agriculture carry out research on different crops.

After completing graduation or Post graduation from Agricultural Universities, meritorious agriculturists join research institutes. They are engaged in research to innovate technology. As a result farmers are capable of using many technologies on improved crop seeds, new varieties and protection from diseases and pests. Besides, research institutes conduct research on animal and fish. Bangladesh Livestock Research Institute and Fish Research Institute are there to do such types of research. Technologies have been innovated on animal and bird rearing and fish culture from research of the two institutions. As a result, the business of protein production has increased. People are informed about developments in agriculture through the publication of leaflets and booklets from all research institutes.

c) Agricultural Scientist : An agricultural scientist is one who works in an agricultural institution and innovates newer varieties. He can explain nicely the life cycle of a crop and he stores different types of agriculture information. Such scientists are developing new crops, animal breeds and preservation method of crops and it is bringing welfare to the country.

Task : Discuss in groups and present the contribution of agricultural research to the field of agriculture.

New words : Farmers' field school, experienced farmers' courtyard meeting, faculty, agricultural scientist, agricultural fair.

Exercise

Fill in the blanks

1. Crop production is the main subject of _____ activities.
2. Fish is the main source of _____ .
3. Pulse crops supply _____ .

Match the left column with the right column

Left column	Right column
1. In agro-based Bangladesh 2. Now-a-days daily fish availability per head. 3. This lion's share of protein	is about 56 gm. overall development depends on agriculture comes from fish

Short answer questions

1. What is called horticultural crop?
2. Who fulfill the basic demands of men?
3. Why are we called rice and fish eating Bangali?

Descriptive questions

1. Describe the areas of agriculture.
2. Explain why agriculture fairs are necessary for getting agriculture-related information and services.
3. Write five names of research institutions and their functions.

Multiple choice questions

1. **Jute Research Institute does research on which crop?**
 - a. Rice
 - b. Jute
 - c. Sugar cane
 - d. Cotton.
2. **If agricultural development occurs in our country**
 - i. living standard of people will increase
 - ii. local industry will be expanded
 - iii. communication system will be developed.

Which one is correct?

- a. i and ii
- b. ii and iii
- c. i and iii
- d. i, ii and iii

Creative questions

1.

**Figure : A****Figure : B**

- a. What is called a field crop?
 - b. Agriculture fulfills man's basic needs. Explain.
 - c. What type of crop is figure "A" crop? Give reason.
 - d. Which crop in the figures is more important in consideration to economy? Give your opinion about this.
2. Mr. Mir Hossain cultivates different kinds of vegetables, flowers and fruits in his house. He is not getting good yield from his garden because of various problems and lack of appropriate advice. Last year an agriculture fair was arranged in his district town, and he saw agriculture-related information leaflets and brought some for reading. By this, he solved problems existing in his garden. Next time he exchanged his experience with his neighbours.
- a. Write an agriculture related problem.
 - b. Agriculture is developing because of experienced farmers. Explain.
 - c. How did Mr. Mir Hossain use his experience learnt in the fair? Explain.
 - d. Analyse the result of Mr. Hossain's exchange of experiences with the neighbours.

Chapter Two

Agricultural Technology & Equipments

Agricultural technology is the combination of concepts, methods, equipments or materials used for agricultural activities. Agriculture has different branches, and so branch based technology is being invented. Some technologies have been used from ancient times. Again some new technologies have come replacing the technology which was available ten years ago. Plough-yoke is still used in Bangladesh though these are ancient agriculture equipments. Again new and more high yielding varieties of different types of rice have occupied the place of Mala, though it is a high yielding rice variety. Accordingly, technology will be being invented and used.



Figure : Tractor

Figure : Charo

Figure: Country Plough

Figure : Wicker

At the end of this Chapter, we will be able to-

- explain the ideas of agricultural technologies.
- explain the use of agricultural technologies.
- explain the use of agricultural equipments.
- explain the benefits of the use of easily available agricultural technology.
- analyze the effectiveness of a necessary agricultural equipments that are made from local available inputs.
- realize the contribution of agricultural technology and equipments.

Concepts and uses of agricultural technology

Lesson-I : Concepts of Agricultural technologies

World population is increasing. Population of Bangladesh is increasing more rapidly. Additional food is required for additional population. Again other agricultural products are required more. Man is always thinking to fulfill this additional demand. As a result, man is inventing newer techniques or technology for cultivation by using knowledge in every era . So what is technology? Men ate meat by hunting animals and birds when they did not learn agricultural work. They ate fruits and roots collecting from forests. When they observed that by collecting fruits-roots and by hunting animals and birds, they could not satisfy their hunger, they fell into a problem. Suddenly they observed that seed germinated if fallen into the soil, plants grew and bore flowers and fruits. There after, the fruits could be eaten. Accordingly they invented the first agriculture as agro-technology. As a result, they started crop production. After that they learnt the technique of rearing wild animals in their homes. It is understood that the fundamental technology of agriculture is crop production and livestock rearing.

How did primitive men do crop production? For this primitive men used pointed sticks to stir up the soil loose in a small place and produced crops. At that time, the pointed stick was the appropriate technology for land ploughing. Then man's food demand could not be fulfilled by ploughing small pieces of land by stirring them up with a pointed stick. Such a technology was necessary by which more land could be ploughed. Man started to think deeply. The result of thinking was the invention of wooden plough, iron plough, power tiller, tractor etc.

Knowledge and techniques gained from research to be used to resolve agricultural problems are called agricultural technologies. The main characteristics of agricultural technologies are:

1. Newness will be within this.
2. Make agricultural activities easy.
3. There will be certainty of more production.
4. Less cost but more profit and
5. Less time will be required.

Subject-wise classifications of agricultural technologies-

Now agriculture is not only the matter of crop production. It is not only animal-bird rearing. Agricultural development occurs with the association of

several production areas. Agriculture has direct relationship with these subjects. Agriculture consists of crop production, animal and bird rearing, fish cultivation and afforestation. Means of agriculture development is the innovation of appropriate technology and proper use of these subjects. Therefore subject wise techniques and technology of agriculture have been identified below in the following chart:

Agriculture subject	Technology
Crop production	High yielding varieties of different crops, salt tolerant variety, cow dung, bio-fertilizer, chemical fertilizer, doses of fertilizer use, insecticide, doses of insecticide use, inter crop, green manure, power tiller, low-lift pump, deep tube-well, bailing vessel, tub etc.
Rearing of domestic animals	improved livestock breeds, improved poultry breeds, Cow fattening, green grass preservation. Duck-fish-rice mixed cultivation, balanced food of poultry, improved incubating method, preservation of eggs through improved method, disease control of animals and birds, etc.
Fish culture	Fish culture in pane, different technology of fish catching, e.g. using wicker, net, hook, treatment of pond water, cultivation of <i>Telapia</i> & <i>Nilotica</i> , fish processing, etc.
Afforestation	Social forestry, agro-forestry, tree and field crop cultivation method, forest and fruit tree cultivation method, tree and fodder crop cultivation method, seedling production method, etc.

Task : Present subject wise-agricultural technologies on poster paper.

New words: Agriculture technology, crop production, rearing of domestic animals, bio-fertilizer, fish culture in pane, cow fattening, social forestry.

Lesson- 2 : Use of agricultural technologies

Agricultural technologies have made agricultural activities easier. So, agriculture is now a profitable profession. Now-a days farmers are ploughing the land by mechanical plough instead of country ploughs. As a result, farmers can save money, time and labour. Food shortage is a great problem of Bangladesh, farmers are trying to meet up the shortage by cultivating high yielding rice. Moreover, technologies have been developed for agricultural activities. Organic fertilizer, chemical fertilizer and green manure are being used for increasing land fertility. Different kinds of hand and energy driven machines are used to sow, harvest and winnow crops. Farmers can do all types of agriculture related work easily due to innovation of these technologies.

Agricultural technologies have many uses. Farmers have been using agricultural technology in every sector of agriculture from time immemorial. Agriculture technologies are being modernized day-by-day. Now-a-days most of the farmers are using power tillers, tractors instead of wooden country ploughs. Uses of some more agricultural technologies are mentioned below:

1. Homestead tree plantation technology:

Everybody plants trees around the homestead. But many of them don't know about the technology of which plants are to be planted in which place of the homestead. Several rules are to be maintained for homestead tree plantation. Sufficient light and air can be available if trees are planted at the homestead following these rules. We will be able to know about these in details in Chapter Six.



Figure : Homestead tree plantation.

2. Maize cultivation in zero tillage :

Maize can be cultivated without ploughing. The land remains muddy after the recession of rain water. If maize seeds are sown in that land, good yield may be expected. As a result, money is earned and less labour is required.

3. Egg preservation in an earthen pot :

Generally eggs do not remain good for more than 5-10 days. By making holes in the floor of a house, eggs may be kept by placing a pot in that hole. Charcoal is kept around the earthen pot in the hole and water is poured on the charcoal to make it wet. The eggs in the pot remain cold and good for 20-50 days.

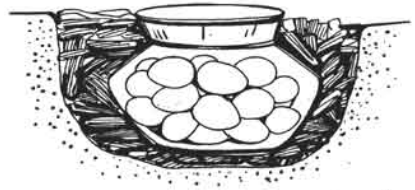

Figure : Egg preservation in an earthen pot

Task : 'There is no alternative to agricultural technology in developing Bangladesh's agriculture.' Discuss in groups and present it .

New words: Egg preservation in an earthen pot, maize cultivation in zero tillage, tree plantation in homestead.

Ideas of Agricultural equipments and Uses

Lesson 3 : Ideas of Agricultural Equipments

Agriculture work is a technical work. Major agricultural activities are done with the help of machinery. Agriculture work is not an individual work. It is a process, combination of many types of works. One piece of work has continuity with another piece of work- such as ploughing is the beginning of agricultural work and crop threshing, winnowing and storing are at the end of agricultural activity. From land ploughing to crop storing all sorts of work depend on machines. The machines that are used to do the agricultural work, are the agriculture machinery.

Population in Bangladesh is increasing, on the other hand land area is decreasing. More crop production from minimum land is a big challenge. Right use of right machinery is necessary to overcome this challenge. For crop production using only good seeds, fertilizers, irrigation or using pesticides are not sufficient. Side by side agricultural equipments are also necessary. The right use of agricultural equipment ensures more crop production.

The use of machinery in crop production is not a recent event, rather it was also used in ancient ages. At that time crop seeds were sown after cleaning weeds by digging soil with the help of wooden, bone or stone-made pointed tools. Men gradually started to use cows, buffaloes, horses and mechanical power for crop production. According to crop and type of agriculture work, uses of machineries are also different.

Agriculture activities for crop production are: land ploughing, seed sowing, seedling planting, fertilizer application, weed control, insect-pest and disease control, application of irrigation, crop harvesting, threshing, winnowing, drying and storing. Machineries are being used in every type of work.

The machines used for land ploughing, seed sowing, weed control, pest control, irrigation, crop harvesting, threshing, winnowing are called agricultural machinery. Some are hand operated and some are power operated among the agricultural equipments.

Task :

1. Make a list of those agricultural activities you have observed in your area. Then match with mentioned types of work in your lesson.
2. Make a list of machineries which are used for what works and present it.

New words : Agricultural machinery, hand operated agricultural machinery, power operated machinery.

Lesson-4 : Uses of hand operated agricultural machineries

In course of time hand-operated agriculture machineries have been improved. Uses of some hand-operated improved agricultural machineries are mentioned below.

BARI plough

Half time is required to prepare the whole land in comparison with the country plough and its advantage is no area of land is left without cultivation in the first plough.

1. BARI ploughs are used to cut and turn over the soil
2. Width and depth of cultivation is more than country plough.
3. Both wet and dry land can be cultivated.

Mould Board Plough

Mould board plough is more effective than country plough.

Its advantages :

1. Every part of this plough is made of iron.
2. This plough cultivates and turns the soil into rectangular chunks.

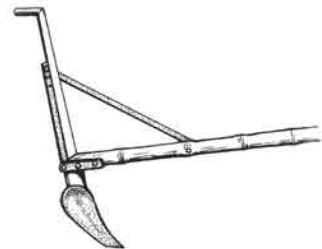

Figure : BARI plough



Figure : Mould Board Plough.

BARI seed sowing machine

It is a hand operated seed sowing machine. Its advantages are:

1. seeds can be sown in right distance and depth,
2. by it seed germination becomes good, and
3. less quantity of seeds are required .

Pesticide spraying machine : Napsak sprayer

A sprayer is used to control crop disease and insects. Water mixed pesticide is filled up and then sprayed having a striger hold at a fixed height. Main parts of the sprayers are :

1. Nozzle, 2. Trigger, 3. Pumping bulb, 4. Barrel, 5. Pesticide spraying hose pipe .

Paddle Thresher

It is an improved hand-operated paddy or wheat threshing machine. Its important parts are :

a drum with tine, a paddle attached to the drum. The drum is rotated with the help of paddle and crops are threshed by the strokes of the tines. It is used to thresh paddy or wheat. It is fully made with local technology.

BARI Pump

BARI pump is a low lift pump. It can be made locally. It is a modern irrigation technology.

Merits are-

1. more water can be raised;
2. water can be lifted from underground and sub-surface.

Task : Go to your village home. See whether the farmers are using the hand-operated improved agricultural equipments. If so, write down the merits of their uses.



Figure : BARI seed drill



Figure : Napsak sprayer.



Figure : Paddle thresher.



Figure : BARI Pump.

New words : BARI plough, Mould Board Plough, BARI seed sowing machine, Paddle thresher.

Lesson-5. Uses of power-operated agricultural equipments

Power-operated different agricultural machineries have been innovated to make agricultural activities easier. Uses of some equipments are given below :

Power tiller

Important parts of it are rotating ploughs. At the time of ploughing the ploughs are rotated at a great speed. As a result the land is ploughed deeply. The soil is well-pulverized and weeds are destroyed. The merits of operating rotating ploughs are that disc or tine ploughs can be used with it. Land can be ploughed quickly and deeply by the power tiller.



Figure : Power tiller.

BARI crop winnowing machine : It can be made locally. The following benefits are found in using BARI crop threshing machine :

1. During bad weather it can be used inside the home.
2. Threshing and cleaning are done in less time and less cost.
3. It is easy to operate.

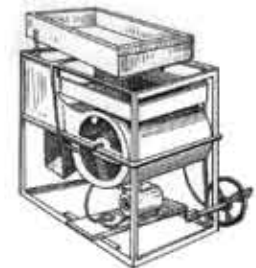

Figure : BARI crop winnower

Centrifugal Pump

It is a power driven irrigation equipment. Low lift pumps, shallow tube-wells and deep tube-wells are operated with the help of this pump. Irrigation is done in the crop field by lifting water from a river or a canal or a ditch with low lift pumps and from the underground with a shallow or deep tube-well.

Merits of Centrifugal Pump

1. Irrigation can be done by lifting water.
2. Water is lifted according to horse power.
3. Can be operated as per need.

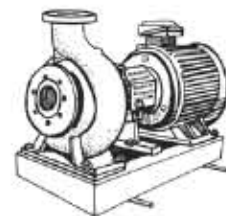

Figure : Centrifugal Pump

BARI Crop Threshing Machine

BARI crop threshing machine is a modern threshing technology. Different types of crops can be threshed by this. Its capacity is more than that of a paddle thresher.

Merits are as follows:

1. Rice, wheat and pulses can be threshed by crop thresher.
2. The equipment works well if crops are with low moisture.



Figure : BARI crop thresher

Task : Make a list of power driven agricultural equipments used by farmers. Write down which equipments are not mentioned in this lesson.

New words : Power tiller, Bari crop winnowing machine, Bari Crop threshing machine , Centrifugal pump

Available Agricultural Technology

Lesson-6 : Selection of Good Seeds

Good seeds bring good crops. That is to say, good crops grow from good quality of seeds. A proverb goes:

“A good child is born in a good family and good crops come from good seeds”. Good seeds are very important to produce good crops. Due to many reasons sometimes good or improved variety seeds may not be good. Many things may be present in the seeds, that may disqualify them an improved variety of seeds.

Characteristics of good seeds

1. They should be free from mixture of different breeds.
2. Seeds should be clean and matured.
3. Seeds colour should be normal.
4. Seeds should not be spotted or eaten by insect or broken.
5. Seeds should be free from the particles of bricks and stone and weeds .
6. Seeds germination rate will be minimum 80 percent.

The land must be disease and insect free to get good seeds. Seeds should be separated from other varieties of seeds, brick and stone particles, weed seeds, grains of paddy containing no rice etc. after harvesting in good manner and by clean threshing-winnowing. However, seeds may be adulterated. So seed selection is very essential.

Seed selection method

Seeds may be selected as follows

a) Selection of seed selecting inputs

1. One forcep, one magnifying glass, one sheet of white paper and a small balance.
2. Specific crop seed.

b) Quantity of seed

1. 10 gm small seeds,
2. 20 gm medium seeds,
3. 100 gm rice or wheat sized seeds.

c) Steps of work

1. Take 100 gm rice seeds by counting.
2. Keep rice seeds on the white paper.
3. Remove the following materials from the seeds.

- * Other variety seeds
- * Broken or insect affected seeds.
- * Immature seeds.
- * Weed seeds
- * Inert material

4. Now weigh, sort out and separate the materials and find out the percentage of selected seeds.

5. Formula : Percentage of selected seeds = $\frac{\text{total seed weight} - \text{separated materials weight}}{\text{Total seed weight}} \times 100$

The higher is the percentage of selected seeds, the better will be the quality of seeds e.g. the seeds will be more rectified. In this way we can identify good seeds by calculating the purity of percentage of seed.

New words: Seed selection, Seed moisture, Seed selection inputs.

Lesson-7 : Green grass preservation

Cattle feed shortage occurs during the dry season. But abundant grass grows in the rainy season, at that time we have to preserve cattle feed for the dry season. For this, green grass preservation method is used. Green grass preservation method is called silage. Nutrient quality of grass is not changed. Grass preserved in the specific place or pit is called silo pit. Silo pits are deficit in oxygen. And due to shortage of oxygen, lactic acid is produced in the grass. This lactic acid helps to preserve the green grass.

Green grass has great importance. Deficit of grass occurs in different places during the winter. Then it becomes difficult to give cattle or animals a standard food. So the shortage of cattle food can be met up by green grass preservation in the rainy season. The quality of silage is important. Milk production of cattle increases with silage having good quality green grass.

The grass that has more carbohydrate is good for silage. For silage or green grass preservation, improved green grass varieties such as Para, Napier, Garman, Gini, Maize etc are used. But silage of maize is much better. Silage may be prepared by mixing with 1 :5 ratio green rice straw and green grass.

Site selection for silo-pit preparation is an important subject. Silo pit should be prepared where rain water is not logged and there is no shortage of grass. Si-lo-pits may be of two types: raw and constructed. Silage preparation method in a raw pit is described below :

1. Firstly select a dry and high place for preserving green grass.
2. A pit should be prepared in a specific place with 1 m deep, 1 m width and 1 m length
3. 700 kg green grass can be preserved in a 1 cubic metre soil pit.
4. Take molasses in an earthen pot weighing 3-4 percent of green grass.
5. After that mix equal quantity of water with molasses.
6. At the bottom of the pit, polythene use is good. A thick layer of straw should be spread if polythene is not used and a layer of straw should be spread around it at the time of arranging grasses.
7. After that, step by step, 700 kg green grass and 20-30kg dry straw should be piled.
8. In every layer of grass, 15-20 kg molasses-water mixture is to be sprayed evenly.
9. Grass and straw are piled step by step in this way and after pressed by foot. As a result, air will go out.
10. When arrangement of grass will be completed, then after putting a layer straw, cover should be given with polythene.
11. Finally on the polythene, 7.5-10 cm thickness of soil should be deposited.

Preserved green grass or silage should be given to cows to eat during the shortage period from October to November. Grass should be pulled out gradually from one side of the pit. Cattle like much to eat green grass preserved by this method, because of good taste and flavour.

Task : According to the above description Make a pit 50cm deep, 50cm wide and 50cm long as per description in a group. Preserve green grass in the pit.

New words: Silage, Green grass preservation, Silo-pit, Molasses, Carbohydrate, Napier, Para, Gini.

Lesson- 8. Fish culture in pane

Demand of fish has been more due to increase of population. Supply of fishes in the market is decreasing due to different reasons. Fishery experts or specialists have given valuable advice to fulfil the demand of fishes. Fish culture in a pane is one among such advice. Now-a-days, in open water, fish culture in pane is getting popularity. Though fish culture in pane is new in our country, for a long time it has been in use in North America, Indonesia, Combodia, etc.

Fish culture in pane is an approved technology of fish specialists or experts. Farmers can cultivate fish in this method in areas having rivers, haors, canals and ditches. Anywhere in open water, river or canal, a pane is given a pond like shape. The most important thing is that fish culture in the pane can fulfill the family nutritional demand, and also a family can earn money by selling this fish in the market.

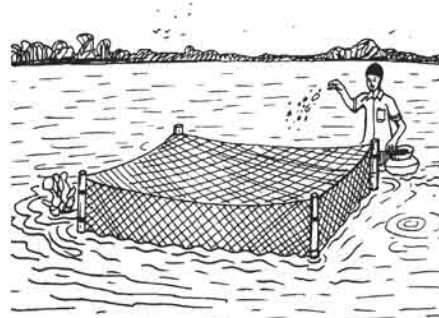

Figure : Fish culture in pane

Before making a pane, firstly place 4 poles at four sides and fasten crosswise bamboo pole sticks to make a rectangular shape. Then the pane is made of net covering the four sides, the top and the bottom of the frame.

In the river or marsh, the soil is to be dug, then bambo pole sticks should be set, binding the pane tightly with this. There is an arrangement on the upper side of the pane to supply food for fishes. The pane may be small, medium or big in size. Measurement of a small size pane is in length 3 m, width 2 m and depth 2 m. Pane size may be two or three times larger in size for the commercial purpose of fish culture. Fish pane may not be only rectangular in size. Again it may be round. Fish pane with many chambers may be prepared by setting net or thick holed net attached to a long bamboo frame. Different types of fish may be cultivated in different chambers.

Pane should be placed where the water flow is slow or flowless. Pane management is hard and costly in strong water flow. Pane should be set by a pole or platform. A platform is a better than a pole. A platform may be made with oil drum. In any depth, a pane may be set, when using a platform. Fish culture in pane is an intensive cultivation. For this, balanced food is very essential. In Bangladesh Tilapia, Nilotika and Carp fishes are cultivated in panes. Among these Tilapia cultivation is profitable. To cultivate Tilapia per 1 cubic meter pane 40-50 fry fish weighing 25-30gm should be released. As feed, wheat bran and fishmeal should be given in course of time by mixing at the rate of 85% and 15%. Food quantity per day will be 3-8% of fish body weight. The whole ground base area of pane will be covered with polythene and then food should be given. Pane net may be filled up with silt and algae. If so, net should be cleaned by brush or brush of bamboo sticks in proper time. From 1 cubic meter pane 20 kg Tilapia production is possible in every alternate 3 months.

New words : Fish culture in pane, Fish specialist, Platform, fishmeal.

Concepts of local agricultural equipments and their uses

Local agricultural equipments are well known to all. These local agricultural equipments are found in every village household. Among the local agricultural equipments, land ploughing equipments, such as country ploughs, yokes, ladders and spades are important. Among the animal rearing equipments such as poultry feeding trays and water pots are the main. Again fish catching equipments such as polos, hooks and nets are the main.

Lesson – 9 : Local agricultural equipments for crop production and uses

Among the local agricultural equipments for crop production, ploughs, yokes, ladders and spade are the main. They are described below :

Plough : The plough is more familiar as country plough. It is made of local materials. The plough is made by fixing an iron tine or sheet to the tip of a curved wood. The Plough with the help of this tine cultivates the land to make furrows. The upper side of the plough is called the handle. The farmers use the plough by pressing this handle. A hole is made in the centre of ploughs. About 8 feet long wood is attached to this hole, whose tip has 4-5 teeth or groves.

It is called the beam. The yoke is attached to the plough by binding a rope with the groove of beam. A small wooden peg is used to keep the beam closely in contact with the plough.



Figure : A country plough

Merits of plough use

- 1) Plough is available.
- 2) Plough is easy to make and operate.
- 3) Plough is easy to carry as it is light in weight.

Yoke : The yoke is kept on the shoulder of the ox or cows and it is attached to the plough. Two holes are prepared on the two ends of the yoke. As per size of the hole, two strong sticks are used through the holes. The yoke is kept on the shoulder of the cows, binding rope with two sticks to attach the plough.

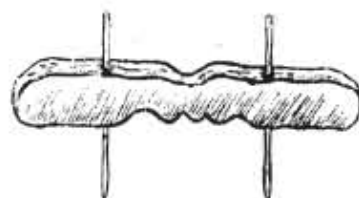

Figure : Yoke

Merits of yoke

- 1) Yoke can be made by bamboo or wood.
- 2) Yoke is easy to make.
- 3) Light in weight.

Ladder : A Ladder is mainly made of bamboo or wood. A fatty bamboo is divided lengthwise into two parts. Three pieces are used in many ladders. The ladder will be 5 feet in length for one pair of cows and 7.5 feet in length for two pairs of cows.

Uses of the ladder are:

- 1) breaks clods.
- 2) levels the land.
- 3) controls and separates weeds
- 4) makes seed germination easier.

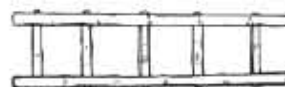

Figure : Ladder

Spade : A spade is a well known equipment for agricultural work. The spade is used to cultivate the land along the boarder lines or the corner where the shear of the plough cannot reach. Besides the spade is used to cultivate the soil of small plots or to cultivate vegetables. Fruit



Figure : Spade

saplings are planted by making pits with a spade. The spade is made of iron sheet. The front side of the sheet is 20 cm. in width and 28 cm in length. About 3 feet long wooden handle is used.

Merits of spade

- 1) It is locally made by the blacksmith.
- 2) The spade can be used to loosen the soil, break solid earth and control weed.

Rake or Harrow :

A rake or a harrow is made of iron spikes, wood and bamboo. A rake has an 1.5m long pole. There are holes after every 10cm in this pole. Bamboo or iron pegs are used in these holes. The handle and beam are used here. The main functions of a rake are:

- 1) crop thinning
- 2) weed control
- 3) loosening the soil

Weeder : The weeder is used to clean the weeds and loosening the soil. The front side of this is made up of a half-moon size iron plate. Again the basal side is narrow and is attached to a wooden handle.

Task : Make a list of equipments used in your house. Compare the prepared list with the equipments mentioned in this lesson.

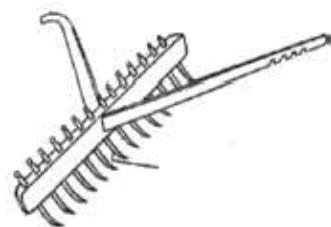

Figure : Rake

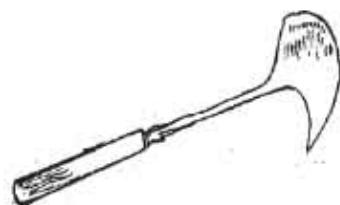

Figure : Weeder

New words: Plough, Yoke, Rake, Weeder, Beam.

Lesson- 10 : Local fishing equipments and their uses

There are many equipments for fishing locally. Among those, Net, Polo and fish hook are remarkable. Different kinds of net, polo, fish-hook for angling are found in almost every household of a farmer.

1. Net : The net is an ancient technique in this country for catching fish. The net is prepared with thread. Fish is caught with a net from pond, ditch, river, canal, khal-beel, even from seas. Fish is captured in the mesh of the net when the net is placed or thrown in to the water. Farmers use different kinds of nets, such as Flying Cast net (Jhaki Jal), Drag net (Thela Jal) and Drift net (Khora Jal)

a) **Flying cast net** : On the upper side of the cast net a narrow rope is used, the lower side of the net is attached to a small size iron stick or ball. A net may submerge quickly when it is thrown into the water. During catching fish, the rope is kept in hand from the bank of river or pond, canal and the net is thrown into water. After that, the net is picked up by pulling the rope. Different kinds of fishes are captured in the lower part of the net. Mini carp, Shrimp, Carp and Nola fish are mostly captured.

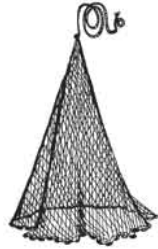

Figure : Flying cast net

b) **Drag net** : A drug net or pushing net has three comers. It is attached to a three - cornered bamboo frame. Generally small fishes are caught with drug net. In the water it is pushed into the front side by holding the handle of the drug net. Mini carp, Khalisha, Shrimp, Bele fish are captured in this net.



Figure : Drug net

Task : Make a list of equipments used by the villagers or your neighbours to catch fish.

c) **Drift Net** : It is a triangular net which is operated from a bamboo frame. The net is tied to a V-shape bamboo frame. The net is put on the path of fish under the water of a river or lake. At a regular interval, the bamboo base of the net is pressed to raise it. Then fish is collected the net.

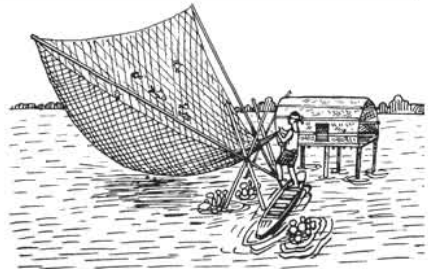

Figure : Drift net

2) **Wicker** : The wicker is an ancient method to catch fish. It is made of bamboo sticks and cane. The lower mouth of it is round or circular and big and the upper mouth is also circular, but small. Both mouths are open. The upper side of the wicker is held by hand and pressure is applied on to shallow water. If fish is blocked inside, it starts moving. Therefore by putting hand through the upper mouth, fish is caught. Big fishes like Shol, Gozar etc are caught with wicker.

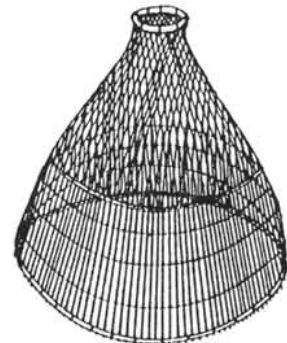

Figure : Wicker (Polo)

3) Hook : The hook is made of iron. About 200 cm long fishing rod is needed for a hook. Special types of fishing rod are found in the market, even in the town. One end of a piece of thread is tied on the tip of the rod and the other end is tied to hook.



Figure : Hook

Different kinds of bait are attached to hooks and thrown into the water. Fishes get caught by swallowing the bait at the time of eating it. Then by pulling the thread, fish is being collected. Hooks are of many kinds. Both a tiny fish and a large catfish are caught by the hook.

New words : Cast net, Drag net, drift net, wicker.

Exercise

Fill in the blanks

1. Agricultural equipments are of _____ kinds.
2. By power tiller, _____ land is ploughed.
3. The wicker is an ancient method to catch _____.

Match the left column with the right column

Left column	Right column
1. Plough	Egg preservation
2. Weed	Net
3. Paddle thresher	Weeder
4. Fish	Land ploughing
5. Earthen pot	Threshing machine

Short answer questions

1. What is called agricultural technology ?
2. Write down the name of five agricultural equipments.
3. Write the benefits of plough uses.

Descriptive questions

1. Describe the continuous changes of ploughs that have been invented to cultivate the land.
2. Explain "Fish culture in the pane is an agriculture tecehnology."
3. Describe green grass preservation method.

Multiple choice questions**1. Which one is crop thresher machine ?**

- a. Power tiller b. Paddle thresher
c. Napsak Sprayer d. Centrifugal pump

2. What is the percentage of germination rate of good seeds ?

- a. 50% b. 60%
c. 70% d. 80%

Read the following passage and answer questions 3 and 4

To meet up the shortage of green grass in his milk farm, Momtaj Miah prepared silage as per advice of Livestock Officer.

3. Momtaj Miah prepared silage in which season?

- a. Rainy season b. Autumn
c. Late autumn d. Winter season

4. The result of preparing silage in the farm of Momtaj Miah –

- i. round the year balanced food will be supplied
- ii. wastage of green grass will be checked.
- iii. cost will be less in the farm.

Which one is correct ?

- a. i and ii b. i and iii
c. ii and iii d. i, ii and iii

5. Which one is used to control crop insect pests ?

- a. Weeder b. Rake
c. Napsak Sprayer d. BARI pump.

Creative questions

1. Kasimpur is an agricultural-technology-dependent village. The farmers here are dependent on machine for agricultural work. In comparison to neighbouring villages, their crop yield is much higher. Agriculture officer, Mr. Rasel motivated the farmers of neighbouring villages Horipur like Kasimpur to use modern agricultural technology. He gives advice to Haripur farmers through house yard meeting and takes villagers to field visits to see the activities of farmers in Kasimpur.

- a. What is called agricultural technology ?
- b. In the agricultural sector modern technology saves the wastage of time. Explain.
- c. Explain the reason of getting more yield by the farmers of Kasimpur village.
- d. Analyse the initiatives of Mr. Rasel for the farmers of Horipur village.

2. Mr. Rafiq, a conscious farmer, always uses good quality selected seed for crop production. This year he purchased some seeds for wheat cultivation. From the seeds, he takes 100 gm seeds by selection and has got the following materials:

- * Other variety seeds- 5 gm.
- * Broken and insect eaten seeds- 6 gm.
- * Immature seeds- 3 gm.
- * Weed seeds- 1 gm.
- * Inert materials- 1 gm.

- a. What colour will good seeds be ?
- b. Mixing of different materials deteriorate the seed quality of improved breed seeds. Explain.
- c. Find out the good seed rate in percentage which is selected by Mr. Rafiq.
- d. Evaluate the work of Mr. Rafiq to produce more crops.

Chapter Three

Agricultural Inputs

Agricultural inputs are very important for crop production. Among the agricultural inputs, soil, water, seed, fertilizer are mentionable. In this chapter we will know in details which crops will grow in what soil, what the characteristics of food seeds are, if there is any need of irrigation in crops, if excess water damages crops and what kind of fertilizer is needed to apply in the land

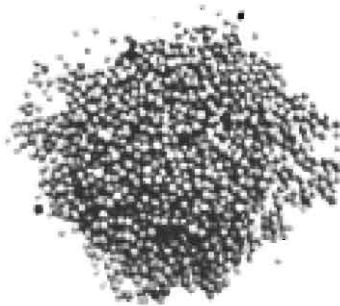

Figure : Loamy soil

Figure : Mustard seed

Figure : TSP fertilizer

At the end of this chapter, we will be able to:

- identify the suitable soil according to use.
- explain the necessity of soil for crop production.
- explain the necessity of water in the agricultural sector.
- describe the classifications and the characterizing properties of seeds.
- identify the uses of different kinds of fertilizers.
- explain the influences of chemical fertilizers on agricultural production.
- evaluate the suitability of fertilizers in agricultural activities.
- the necessity of using adequate water in agricultural activities.
- raise awareness about the bad effect of excess uses of chemical fertilizers.

Lesson 1 : Soil composition

Soil is a natural body and a mixed material. Man grows crops by ploughing this soil. Do we know how the soil has been formed? Scientists believe or think that the earth was like a burning ball in the beginning. For a long while by diffusing heat, this ball has become cold and formed a rocky, and hard earth surface. Soil is formed when rocks erode naturally with the passage of time.

At the end we can say- soil is :

- i. a natural substance, which is formed by integration of minerals and organic matters.
- ii. the uppermost layer of the earth surface, which gives support to the plants.
- iii. different layers are formed into different thickness and every layer has different physical, chemical and biological characteristics.

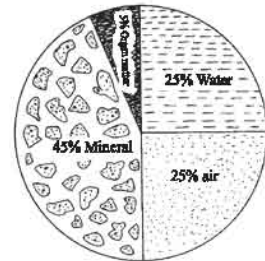

Figure : Component of soil

Components of soil : Soil consists of 4 major components: (1) inorganic material or mineral material, (2) organic material (3) water and (4) air.

1. Inorganic or mineral materials : We have learnt earlier that earth surface is basically created from rocks. The natural forces like temperature pressure, rainfall, wind, air and snowfall, etc. have crushed parent rocks and created inorganic or mineral materials in the passage of time. The sand, silt and clay particles are mineral material of soil.

Thus mineral material are mixed at various proportions and have formed different soil textures. On the basis of volume, mineral materials in this soil occupy maximum part of the soil is about 45%.

2. Organic material : Organic materials is an important element of the soil. Organic materials in the soil are created as a result of decomposition of plant and animal dead body, homestead plants, vegetable wastage, leaves, straws, stool of animals, etc.

On the basis of volume, 5% of such materials are present in the soil. Organic materials is called the life of soil. Because of the activities of soil, micro-organism increases in the presence of organic materials .

Moreover organic material :

- (1) improves physical, chemical and biological characteristics of the soil
- (2) prevents soil erosion
- (3) makes the air and water movement of the soil easier
- (4) increases number of earthworms and their activities in the soil and
- (5) controls soil moisture and temperature.

3. Water : Water is a very important component of the soil. Water retains between the pore spaces of soil particles. Water contained in the soil makes the

plants, nutrient elements soluble and keeps the soil moistened. The main sources of water in the soil are the rainfall, atmospheric moisture or clouds, underground water and irrigation. The ideal soil contains about 25% water.

4. Air : Air is an important component of the soil. Air exists between inter particle spaces of the soil. The noduler bacteria of plants, fungus and other micro-organism activities that require oxygen are provided by the soil air. The quantity of air in the soil is about 25%.

Task : Prepare a paper model according to the elemental percentage of soil components and hang that model in the class room.

Lesson-2 : Classifications of soil

Mineral particles whose diameter is 2 mm or less than that are called soil particles. We know that soil texture is formed by these particles. The comparative quantity or percentage of ratio of sand, silt and clay particles in the soil is called soil texture. These soil particles get mixed together at different proportions and make different types of soils. We need to remember that the size of particles are different.

Now, we will learn about the classifications of the soil. It is very important to know the classifications of soil, which crops grow in what soil. For agricultural purpose, the soil has been divided into 3 main categories depending on the textural variation. There are (a) sandy soil (b) loamy soil and (c) clayey soil.

(1) Sandy soil : The soil that contains 70% or more sand particles is called sandy soil. Crops cannot grow suitably in sandy soil, where particles are coarse. But by applying huge compost, cow-dung and green manure-crops like Indian millet, Italian millet, melon, potato, water melon, etc. can be grown in sandy soil.



Figure : Sandy soil

(2) Loamy soil : The soil that contains less than 70% sand particles, but more than 20%, is called loamy soil. However typical loamy soil should contain fifty percent sand particles and the rest half is composed of silt and clay. This soil is suitable for cultivation. All kinds of crops can grow well in this type of soil. Soil of majority areas of Bangladesh is of loamy type. Loamy soil is again divided into 3 categories such as- (1) sandy loam soil, (2) silty loam soil and (3) clay loam soil.



Figure : Loamy soil

(3) Clayey soil : The soil that contains minimum 40% of clay particles is called clayey soil. Silt particles are also present more in this soil. This soil is found in northern part of Dhaka district. Eastern part of Tangail district and South-western part of Mymensingh district. This soil is very difficult to be ploughed. This soil may be suitable for cultivation by applying organic fertilizers. Rice, jute, sugarcane and vegetables grow well in this soil.



Figure : Clay soil

Task 1 : Answer the following questions: (1) What is soil texture ? (2) How is the soil texture determined ? (3) How many types of soil are there depending on texture and what are they? (4) Which soil is suitable for cultivation ?

Task 2 : Make a list of ten crops, that grow in sandy, loamy and clayey soils.

Lesson-3 : Properties of soil

Soil properties influence crop production. What kind of crops can be produced on which types of soil depends on its characteristics. Properties of all soils are divided into 3 classes, such as: (i) physical properties (ii) chemical properties and (iii) biological properties.

a) Physical properties of soil : Physical properties of soil mean : (i) soil texture, (ii) structure, (iii) soil density, (iv) soil colour, (v) soil temperature, (vi) water holding capacity of soil (vii) air movement in soil, etc.

b) Chemical properties of soil : Chemical properties of soil mean - (i) acidity and alkalinity, (ii) quantity of available plant nutrient, (iii) salinity of soil etc.

(c) Biological properties of soil : Biological properties of soil mean - (i) type of micro-organisms, (ii) number of micro-organisms, (iii) functions of micro-organisms etc.

Importance of soil properties in crop yield : The importance of soil properties is unlimited for crop production. Soil texture, soil structure, soil density, etc. of the physical properties of soil influence crop production. The soil is classified into different categories according to differences of soil texture. Most of the crops grow well in loamy soil. Paddy grows well in clayey soil due to its high water holding capacity. Sandy soil grows ground nut, potato, water melon, etc. well. The arrangement of sand, silt and clay in a certain defined pattern is called soil

texture. Granular and crumby soil structure is more favourable to crop cultivation. Plate like soil structure has high water holding capacity. Among the chemical properties - soil acidity, alkalinity and salinity are very important. Most of the crops do not like high acidity, alkalinity or salinity in the soil that means neutral soil is more suitable for crop cultivation. This kind of soil contains higher amounts of available nutrient for plants and higher activity of micro-organisms.

Biological properties of soil are the quantity, category and activity of the living organisms and micro-organisms like worm, fungus, bacteria, algae etc. These organisms and micro-organisms do much good in producing humus in the soil and making them available as nutrients for crops.

Task : Write the properties of sandy, loamy and clayey soils and present in class

Lesson 4 : Irrigation

Do we know, which elements are maximum in a living body without which life cannot exist? What is called life of a living thing? The answer of all these questions is water. So where do living beings get water and where from? The plant is a living being and it gets water from irrigation or rainfall. When the water is comparatively more than the required amount, it needs to be removed and it is called drainage. Now we would discuss irrigation and drainage of water.

Artificial supply of water in the field for crop plant growth is called irrigation. Water is essential for the life of any living being and so it is necessary for crops. To give production and for normal growth of crops, plants absorb water soluble plant nutrients and the required amount of water contained in the soil. Due to drought, less rainfall or because of other reasons, water is essential in the crop field. Irrigation is necessary for modern agricultural system.

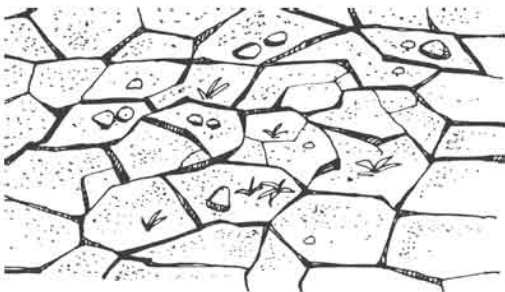

Figure : Drought affected field crop



Figure : Crop in normal field

Sources of irrigation water: Irrigation water is mainly found from two sources, such as (a) surface water (b) underground water.

Sources of surface water are rivers, canals, ditches, haor (marshes), baor, ponds, etc. This water is mainly stored from rainfall.

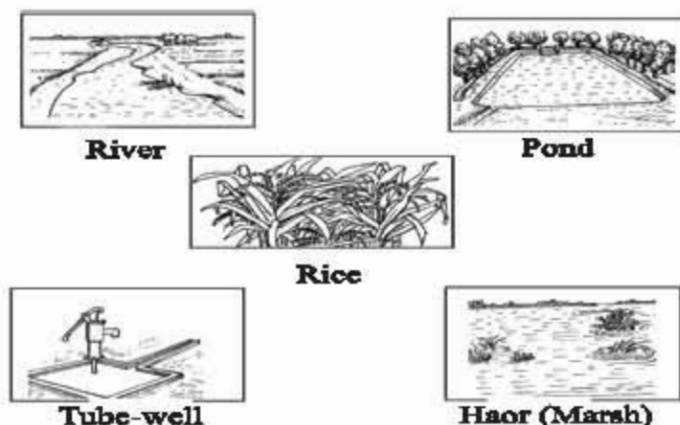

Figure : Different sources of irrigation water in rice field.

On the other hand irrigation is done by digging well or lifting underground water using shallow tube-well. This water is called underground water.

Lesson-5 : Necessity of irrigation

Bangladesh is an agricultural country. In this country there is sufficient rainfall. But this rainfall is not always used. So, good harvest can not always be got, if crop is cultivated depending on rain. In our country there is enough rain in the rainy season, but there is almost no rain in the winter season. Moreover, there is not enough rainfall during the monsoon season in the western region of the country. As a result, the production of crops decreases due to shortage of water. In this situation, irrigation is needed to increase crop yield. There are differences in the demand of water at different stages of growth for each crop. So irrigation is needed to provide water according to this demand.

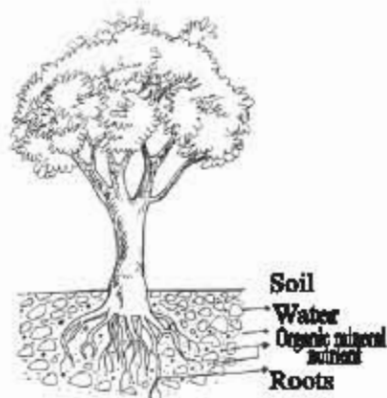

Figure : Water absorbed with roots

Merits of irrigation : (i) Plants absorb water using its roots. (ii) Plants absorb nutrients along with the water from the soil. (iii) Irrigation helps keeping the

soil temperature right. (iv) Effectiveness of micro-organisms and availability of nutrients are increased.

Draining excess water : Excess water should be drained away from the land. The activity of draining excess water from the land is called water draining. Plants lack oxygen if excess water gathers in the land. As a result many plants die.

Lesson 6 : Water for fish culture

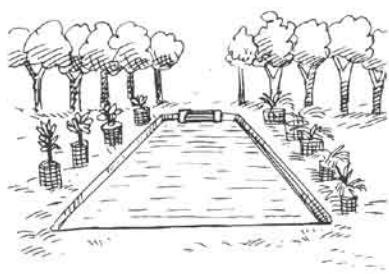

Figure : Pond

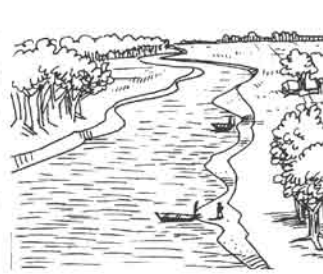

Figure : River



Figure : Canal.

We look at the above pictures. What can we see? We can see water in a pond, in a river and in a canal. We know which beings live in this water. We fulfill our need of protein by eating these beings. We call them fish. So to cultivate fish in water, we have to know something about it. We know, we need houses and good environment for our living; and also fishes need good environment for living. Let us discuss the quality of water and its impact on fish culture.

Physical properties of water and their influence on fish culture : The productive capacity of a pond can be assumed by observing the physical condition of water in it. The physical properties of water in fish culture is discussed below:

(1) Water colour : Light green coloured water indicates more productivity of a pond. Water colour is different because of different types of organic and inorganic materials. Productive capacity may be assumed by seeing the water colour. It should be understood that there is natural food for fish in water if the water is green or brown green. The colour of water can be maintained by applying fertilizer regularly into the pond.

(2) Clearness of water : The productive capacity of a pond is more when the clearness of water is upto 25 cm or below. Besides, it is understood that there is not enough food for fish if the palm can be seen when a hand is submerged up to elbow. So fertilizer should be applied in the pond.

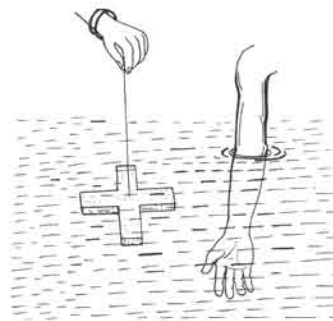

Figure : Test of Natural foods

(3) Depth of water : Depth of water is an important element for fish culture. For fish culture the depth of water of a pond ranges between 1.5-3 metre. So 2 meter depth is best for fish culture. Sunlight cannot reach in the deep water, if water depth is too much. Moreover, the water may warm up if the water depth is too short.

(4) Water temperature : The growth of fish also depends on the temperature of water. Growth of fish is less during winter and more in summer. For Rui (carp) culture the best temperature range is 25°C-30°C.

(5) Sunlight : Food production depends on sunlight. So, high trees on the bank of the pond should be cut for entrance of sunlight profusely into the water. The floating water hyacinth, algae and weeds create obstruction to enter the sunlight into the water.

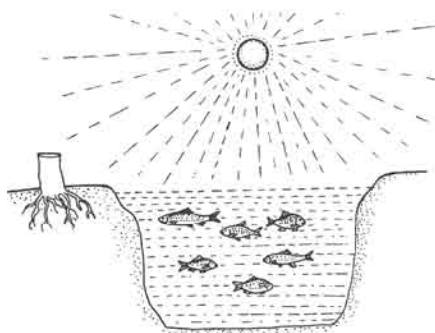

Figure : Sunlight in the pond

Chemicals properties of water and their influence on fish culture : Some chemical properties of water for fish culture are discussed.

(1) Dissolved Oxygen : Oxygen released by aquatic plants is dissolved in water. Some amount of oxygen from air is also mixed with water. The fish in the pond, aquatic plants, animals respire with the help of this oxygen. For lack of oxygen, fishes unitedly float on the water. It is called gasp of fish.

Causes of decreasing oxygen in the water :

(1) Decomposition of leaves and branches of plants. (2) Use of excess raw cow dung (3) Cloudy sky (4) Water being too muddy.

Recovering oxygen deficiency: Defficiency of oxygen in water can be recovered instantly by creating waves on the water surface. Waves can be created by swimming or stirring the water using bamboo.

(2) Dissolved carbon-dioxide : If the amount of carbon-dioxide is increased in

the water somehow, poisoning occurs. If the bottom of the pond contains too much organic matter and mud, there will be excess of gas due to high temperature.

(3) **Water p^H** : Whether the water is acidic or alkali can be determined by p^H metre. If p^H value is less than 7, it is acidic water, if more than 7, it is alkaline and if 7 it is neutral. Relatively alkaline water is good for fish culture. So the water p^H 6.5-8.5 is helpful to grow natural food in a pond.

(4) **Phosphorus** : Phosphorus increases the amount of fish food in water

(5) **Nitrogen** : Nitrogen is very beneficial to aquatic micro-organism. This micro-organism is the principal food for fish.

(6) **Potassium** : There is need to apply potas in the water to fulfill the demand of food for fishes.

We came to know from the above discussion that water is necessary for fish culture.

Fish production in a water body depends on the properties of water.

Task : Discuss in groups and present the impact of water quality on fish culture

Lesson 7 : Water for livestock

Water is called life. Without water man, animal-birds and plants cannot live. Water is essential to the translocation of nutrient elements from one place to another in the body. It is necessary for digestion, metabolic activities and to emit polluted matter from the body. Water has a role to control body temperature. Water is an essential element for living bodies. Water is maximum among the body building elements. The amount of water in the animal body is about 70%.

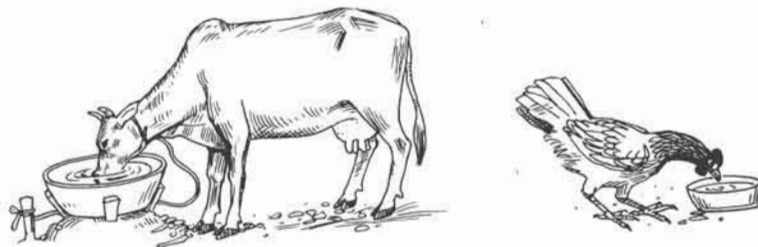

Figure : A domestic animal and a domestic bird are drinking water

Sources of drinking water for domestic animals and birds : Clean and pure water from a tube well, pacca dug well, pond, etc.

Functions of water in the bodies of animals and birds : Water helps to
 (1) absorb food, (2) control body temperature and digest food,

(3) transmit nutrients to the cell, (4) maintain body fluidity and (5) transport different types of enzymes.

Water deficiency problems of domestic animals and birds : There will be obstacle to taking other foods if sufficient amount of water is not taken.

The production of animal and birds, and their weight will decrease. The birth of a baby or laying of eggs may face danger from water deficiency during pregnancy of domestic animals and birds. They may die even due to shortage of water.

Solution : Cattle need to drink plenty of clean and pure water. Take special care so that animals and birds cannot drink polluted water. Water should be sterilized. Besides this, the necessity of water for animals and birds depends on food, weather and age. Water is more needed in summer than in winter. Water is required more if dry grass and granular feed are taken more.

Water requirement : Water is more essential for milking cows.

A milking cow daily drinks 30-40 litres of water. A hen drinks water double of its food taken. It is estimated that a hen daily drinks 200-300 ml. of water.

Task : Write down what will happen if insufficient water is drunk by a milking cow.

Lesson 8 : Characteristics of seeds

The seed is the medium of plant breeding. New plants grow from the seed. Seed means fertilized and mature ovule, for example, the seed of paddy, wheat, jute, etc. In broad sense, seed means any living part of plants which is used as the medium of propagation of paddy, stalk of sweet potato, stem of sugar cane, leaf of air plant, onion, potato, etc.



Figure : Soybean (Sohag)



Figure : Ground nut



Figure : Lady's finger



Figure : Maize



Figure : Black gram (BARI-3)

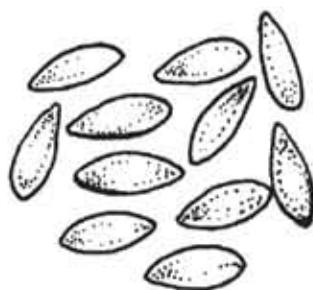

Figure : Cucumber

Task : In your class identify seeds by seeing some of them and in which plants they grow in Bangladesh .

Lesson 9 : Characteristics of good seeds

So far we have seen many seeds and can identify the names of seeds. Now we will know about the characteristics of a good seed.

1. Purity of seed : Any kind of other crop seed, weed seed, stone particles, etc should not be mixed with expected crop seeds and so care should be taken. The purity of seeds will not be maintained otherwise.

2. Variety purity : Purity of seed is lost, when any seed sample contains seeds of other varieties of the same crops. Such as if, Nazers hail rice seed is mixed with Binashail rice seed, the seed will not be varietally pure. Breed or variety purity will be maintained if the seed is produced and processed in a controlled environment.

3. Germination capacity : This matter is called the germination capacity of seed. The quality of seed is measured by determining the percentage of germination of seed in a particular sample. The germination capacity may be upto 100% of a good seed. But all the time all seeds do not germinate at this rate. If at least 80% of the seeds germinate, they may be called good quality seeds.

4. Vigorousness of seed : When the seedlings of the sample are vigorous, living and healthy and can grow under adverse conditions, the seeds are called as high vigorous seeds.

5. Humidity of seed : The percentage of moisture contained in the seeds of the sample is called seed moisture. Seed moisture keeps seeds living. 8-10% moisture is better to keep cereal seed grains well.

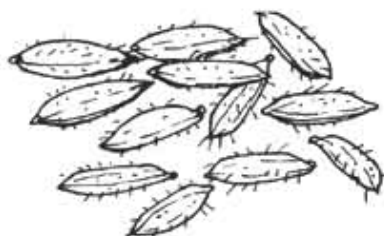

Figure : Rice seed (Normal)



Figure : Rice seed (abnormal)

(6) Seed colour : Seed of every variety has an independent colour. So a good seed should have normal bright colour. Normal bright colour is the primary symptom for identification of good seeds.

Lesson : 10 : Classification of Seeds

Classification of seeds will be discussed in this lesson. Seeds may be classified in different ways, such as :

1. According to use, seeds are divided into two division :

(a) Botanical seed : According to plant scientists fertilized and mature ovule is called seed for example- rice, jute, wheat etc. seeds .

(b) Agronomical seed : According to agronomical scientists, any plant part that under favorable conditions can produce new plants of self variety is called an agronomical seeds for example: zinger and turmeric bulb, vine of sweet potato, teasel gourd root, sugarcane stem, etc.

2. Seeds are divided into two categories based on the presence of seed coat, for example:

(a) Seeds without seed coat : There is no seed coat in this seed, such as pine, cycus, etc.

(b) Seed with seed coat : Seed coat is present in these seeds, such as rice, mustard, etc.

3. Seed is divided into 3 divisions according to cotyledon. For example:

(a) **Mono cotyledonous seed** : Only one cotyledon is in these seeds, such as- rice, wheat, maize, etc.

(b) **Di cotyledonous seed** : Two cotyledons are in these seeds, such as- gram, mango, jackfruit, etc.

(c) **Poly cotyledonous seed** : More than two cotyledons are in these seeds, such as pine.

Task : Classify seed samples from some sample mixture of various seeds.

Lesson- 11 : Classification of Fertilizers

Plants take food from the soil as similar we eat food. Plant needs 17 essential nutrients to complete its life cycle. But it does not need all the nutrients in equal quantity. It requires some of the nutrients more. We use these nutrients such as urea, TSP, MOP as fertilizer.

Fertilizers are classified into two categories based on its sources.

- a) Organic fertiliger
- b) Chemical fertilizer



Figure : Urea



Figure : TSP



Figure : MOP

a) **Organic Fertilizer** : The Fertilizer which is produced from bodies of living beings, that is, from debris of plants and animals is called organic fertilizer such as cow-dung, compost fertilizer, green manure, oil-cake etc. All necessary food elements of plants are available in the organic fertilizer.



Figure:Organic Fertilizer

Advantages of using organic fertilizer in the land

- All the necessary plant nutrients are available in the organic fertilizer.
- It increases fertility of the soil.
- It increases the activities of the soil micro-organisms.
- It develops soil structure.
- It increases water absorption capacity of soil.
- It increases air movement in the soil.

b) Chemical fertilizer

Fertilizer produced in the factories is called chemical fertilizer e.g. urea, DAP, zipsum, zinc etc.

The table below shows a list of some fertilizers and the nutrients :

Names of fertilizers	Names of nutrients
urea	nitrozen
TSP	Phosphorus, calcium
MOP	potassium
DAP	Nitrogen, phosphorus
Zipsum	Sulpher, calcium
Zinc	Zine, sulpher

Advantages of applying chemical fertilizer

1. Right amount of nutrients are added to the soil as the plants require.
2. Chemical fertilizer is very effective to meet plant nutrient deficiency.
3. It plays an important rule to increase crop production.

Disadvantages to apply chemical fertilizer

1. It can harm soil and crop if not applied evenly.
2. It increases production cost.
3. Excessive use of chemical fertilizer pollutes the environment.

Task : Prepare a list of organic and chemical fertilizers.

Lesson -12 : Use of fertilizer in agricultural activities

Bangladesh is a populous country. Population of the country is increasing every year but the quantity of cultivable land is decreasing. So it is essential to apply fertilizer to produce a large quantity of crops from a small area of land. The demand of fertilizers in Bangladesh is increasing day by day. Organic and inorganic fertilizers are mainly used in our country. But some factors are to be considered to apply the right quantity of any specific fertilizer, for example :

1. Condition of soil fertility
2. Type and variety of the crop
3. Time and methods of applying fertilizer
4. Degree of fertilizer loss
5. Level of soil moisture

Task : Discuss in group and present on "the role of fertilizers in crop production".

Exercise**Fill in the blanks**

1. Seeds are the medium of the _____ of plants.
2. In modern agriculture system _____ is essential.
3. Urea is a _____ fertilizer.
4. Organic fertilizer increases the fertility of _____ .

Match the left column with the right column

Left column	Right column
1. TSP fertilizer 2. Underground water irrigation 3. A seed is the chief medium 4. The large amount of soil composition is 5. Agronomical seed	Propagation Mineral matter Leaves of sweet potato Tube-well Phosphorus.

Short answer questions

1. What sort of crops can be cultivated in the sandy soil?
2. What are the qualities of a seed?
3. How can the purity of a seed variety be preserved?

Descriptive questions

1. Describe the elemental components of the soil.
2. Describe characteristics and classifications of seeds.
3. Describe classifications of fertilizers with examples.

Multiple choice questions**1. Which one is botanical seed ?**

- | | |
|-----------|------------|
| a. Ginger | b. Maize |
| c. Jute | d. Mustard |

2. Which element does a plant get from urea fertilizer?

- | | |
|-------------|---------------|
| a. Nitrogen | b. Phosphorus |
| c. Sulpher | d. Pottassium |

3. The function of water in the body of living beings

- i. transport nutrient elements to the cell
- ii. maintain body fluidity
- iii. help to transport enzymes

Which one is correct ?

- a. i & ii b. i & iii
- c. ii & iii d. i, ii & iii

4. Which crop can be bred by using body organs stem ?

- a. Rice, cucumber, wheat b. Jute, mustard, soybean
- c. Maize, black gram, ground nut d. Sugar-cane, Pointed Gourd, sweet potato.

Read the following passage and answer the questions 5 and 6

Marzia Begum, a resident by the river Dhaleswari, built a dairy farm and got the expected amount of milk production. Two of her cows are sound and they possess beautiful, soft skin. Among the different cares of farm management, she used to make the two cows drink sufficient water every day.

5. How many litres of water did Marzia Begum give the two cows ?

- a. 20-40 litres b. 60-80 litres
- c. 40-60 litres d. 80-100 litres

6. What is the reason of having soft skin of the two cows belonging to Marzia Begum?

- a. She makes them drink sufficient amount of water
- b. She feeds them necessary granular food
- c. She gives them a specific amount of grass
- d. She bathes cows on a regular basis

Creative Questions

1. The yard of a farmer named Majid, gets filled with straw, empty grains and leaves in every threshing season of crops. As a result, the environment surrounding the house becomes dirty and unhygienic. With the advice of the sub-assistant agriculture officer, Majid adopted the method of utilizing the wastage and applied these to his agricultural fields.

- What is called organic matter ?
- The crop production of a field depends on soil texture. Explain.
- How will Majid utilize the wastage of his house? Explain the method.
- Analyse how Majid's decision will influence his agricultural activity.

2.

Group	Nature of soil Particle	Classification of soil	Crop/Characteristics
A	70% sand	?	a kind of melon (futi), a kind of melon (Bangi), water melon
B	40% sand	Loamy Soil	?
C	60% sand	?	make the land suitable for rice cultivation

- What is called soil ?
- Why are organic matters called the life of soil? Explain.
- Explain why the soil in group C can be made suitable for rice cultivation.
- Which soil in the chart is the best one for crop cultivation? Give reasons.

Chapter Four

Agriculture and Climate

Agriculture depends on weather and climate. The change of the elements of weather and climate influences cultivation of crops, fishes and rearing domestic animals-birds. Moreover due to climatic changes global temperature is increasing and ecological balance is hampered. As a result floods, drought, salinity, cyclone, etc. break out in disastrous forms. In this chapter we would learn the concepts of weather and climate, their elements and their impact and importance on agriculture. Besides, we would know about the agro-ecological zones, the rainfall, flood, and tidal prone areas of Bangladesh.

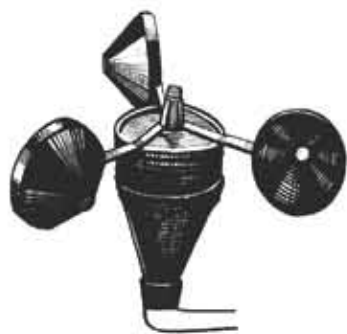

Figure : Barometer



Figure : Thermometer



Figure : Rain gauge.

At the end of this chapter, we will be able to :

- analyse the importance of weather and climate in agricultural activities.
- identify agro-ecological zones on the basis of weather and climate.
- identify low rainfall, heavy rainfall, flood prone, tidal areas in the map of Bangladesh.

Lesson- 1: Weather and Climate

Weather: We hear the news of weather on radio and television. We get the information of temperature, humidity, rainfall of the day from this news. We also come to know about the future information of temperature, humidity, condition of the sky. This future information is said to be weather forecast. So the daily condition of the atmosphere of a particular place is called weather. The characteristics of the weather are given below:

1. It is influenced by the local monsoonal wind blow.
2. Weather is quick changing.
3. It does not influence much on the qualities of the soil.
4. Weather influences on the nursing of crops of a particular place.

Climate: We often hear the terms ‘climate change’ If we want to know about climate, we first need to know about weather. The climate of a place is the average of weathers of the duration of 25-30 years of that place. The characteristics of the climate are given below:

1. Climate is the average condition of the atmosphere in a place for a long time.
2. Climate is slowly changing.
3. It influences on the qualities of the soil.
4. It influences on the varieties of crops and the selection of breeds of a particular place.

Task : Write down the differences between weather and climate in bullet from in your exercise book and present them on the board.

Now we will discuss the elements of weather and climate.

Elements of weather

1. **Rainfall :** Rainfall is the water drops from the atmosphere on the surface of the earth. It includes rain, snowfall, hailstorm, fog, dew etc.
2. **Temperature:** The degree of cool or heat of a place at a particular time is temperature
3. **Wind Velocity :** Wind velocity is the speed of the air blows in a place at a particular time.
4. **Wind direction:** Wind direction is the movement of the air blowing from one place to another.
5. **Humidity:** The quantity of vapours in the air is called humidity.
6. **Atmospheric pressure:** The force that the air applies on the surface of the earth is called atmospheric pressure.

7. **Clouds or cumulus:** The quantity of clouds in the sky.
8. **Visibility:** The range of the distance that can be seen with the bare eyes is called visibility.
9. **Sunlight:** The quantity of the light of the sun that we get in a day and for how many hours is called sunlight.

Elements of climate

1. **Solar Radiation or Solar Diffusion :** The source of all forces on earth is solar-power. Weather and climate vary on the difference of the availability of solar radiation for differences of places and seasons. Solar radiation controls atmospheric temperatures by heating the surface of the earth. Moreover, water vaporization, mobility of the air, creation of clouds are controlled by solar radiation.
2. **Air Mass:** Accumulated air moves in a particular direction. The weather and the climate of a place depend upon the source place of air mass.
3. **Atmospheric Pressure Process :** The rise and fall of atmospheric pressure influences the seasons of rainfall. When atmospheric pressure declines, the possibility of cyclones, clouds and storms rises. When atmospheric pressure rises, dry weather persists or prevails.
4. **Ocean Current :** Ocean current controls temperature and rainfall of coastal areas. Temperature and rainfall get lower when air blows on cold current. If air current is warm, both rise.
5. **Land relief or unevenness :** The height of a place from sea-level controls the climate of that place. If height rises, temperature and atmospheric pressure becomes lower.

New Words: Weather, climate, weather forecast, elements of weather and climate.

Lesson-2: Importance of weather and climate in agriculture.

Agricultural work depends on weather and climate. Agricultural production is influenced by the elements of weather and climate. In this lesson we will discuss the importance of weather and climate on crop cultivation, pisciculture and rearing of domestic animal and birds.

1. Crop cultivation : Bangladesh is an agricultural country. Different kinds of crops grow in this country throughout the year. This has become a country of crops and greenery as there exist different types of temperature, rainfall, humidity suitable for different crops. Paddy, jute, vegetables, fruits grow abundantly during summer for the influence of monsoon climate. On the other hand, different types of summer (robi) crops such as pulses, oil-seeds, vegetables, spices grow for the influence of winter climate. So the influence of climate is very significant in crop cultivation. Again everyday agriculture work is influenced by weather. Land preparation, seed sowing, fertilizer application, irrigation, crop harvesting, spread of diseases and insect pest are immensely

influenced by the elements of weather. For example, a land cannot be ploughed when it rains; again rain is necessary for land preparation of transplanted aman rice field.

2. Fish cultivation : Abundant rainfall occurs in Bangladesh during the rainy season under the influence of the monsoon climate. As a result, rivers, canals, ponds, ditches are filled with water. A lot of fishes are produced in these watery bodies. The impact of monsoon climate is very vital in the production of fish and their breeding

3. Domestic animals-birds : The weather and the climate of Bangladesh are appropriate for rearing livestock such as cows, goats, buffaloes, ducks, hens (poultry), and so on. Different types of grass, creeper and herb grow in this country in a large quantity for feeding livestock.

At present elements of weather and climate behave abnormally due to global climate change. So agricultural production is now under threat. Now we will know about climate change, its causes and effects.

Climate Change: If we want to understand climate change, first we need to realize greenhouse effect. In cold countries, costly vegetables, fruits grow in greenhouses or glasshouses. Temperature in glasshouses remains warmer than that of outside and this is suitable for those crops. The light that enters into the glasshouse cannot get out; rather it becomes weaker and produces heat. As a result, the glasshouse remains warm. The atmosphere of the earth is getting excessively warmer like the greenhouse. The quantity of carbon di-oxide, methane, nitrous oxide, chloro-fluro carbon gases is increasing because of man's different activities. These gases absorb heat and are warming the atmosphere. This is called greenhouse effect and the gases responsible for this are called greenhouse gas. Global temperatures have been increasing since the last quarter of the nineteenth century. The heat of the atmosphere and the sea water is rising. As a result, abnormal behaviour of weather and climate are noticed. This is climate change.

Causes of climate change : Due to industrial revolution emission of greenhouse gases is rising because of man's luxurious life-style. Fossil fuel is burnt in different industries, vehicles and domestic uses. So the quantity of greenhouse gases is increasing in the air. Again population is increasing every year. A huge amount of forest land is being exhausted for their food and habitation. So the balance of the absorption of carbon di-oxide by trees is not maintained.

Demerits of climate change : The ecological balance of natural environment is hampered due to climate change. The rise of the sea level, the melt of ices in the

polar regions and the mountainous glaciers, deforestation are being accelerated. As a result disasters like heavy downpour, drought, salinity, flood, increase of severity and durability of floods, increase of extremity of cyclones, excessive heat and excessive cool have become frequent. As a result, agricultural production is disrupted. A change is necessary to bring about a change in the method and management of agricultural production.

Task : Discuss the importance of climate in agriculture and write it down in your exercise book.

New Words : Climate change, greenhouse effect, greenhouse gas.

Lesson- 3 : Weather and Climate of Bangladesh

If we consider the geographical position, sea-level height and distance, temperature and rainfall of Bangladesh, we find that its climate is moderate or equable. The main characteristics of the climate of Bangladesh are proper rainfall, moderate winter and wet summer. There is not such vapour in the air flowing from the north and the north-west direction during winter (November-February). So there is scarce rainfall. On the other hand, it rains heavily during the summer as there is much vapour in the air flowing from the south and the south-west direction. Moreover, sudden storms and cyclones strike from the north-west direction during March and April months. These are called nor' wester storms. These storms are accompanied by hailstorms. Depression is also formed in the ocean during the summer. As a result, cyclones occasionally hit coastal areas. Some of the main characteristics of the climate of Bangladesh are discussed below :

- 1. Temperature :** The highest temperatures in Bangladesh during the summer is 34° Celsius and the lowest is 21° Celsius. In Bangladesh during the winter, the highest temperature is 29° Celsius and the lowest is 11° Celsius. January is the coldest month. The average temperature is 17.7° Celsius during this month. During the winter in the southern part of the country near the coastal areas, temperature remains high and in the northern part, it remains low. Bangladesh is divided into five regions according to the duration and intensity of coldness such as T₁, T₂, T₃, T₄ and T₅. The duration and intensity of coldness is the lowest in T₁ region and being gradually increased, it becomes the highest in T₅ region.

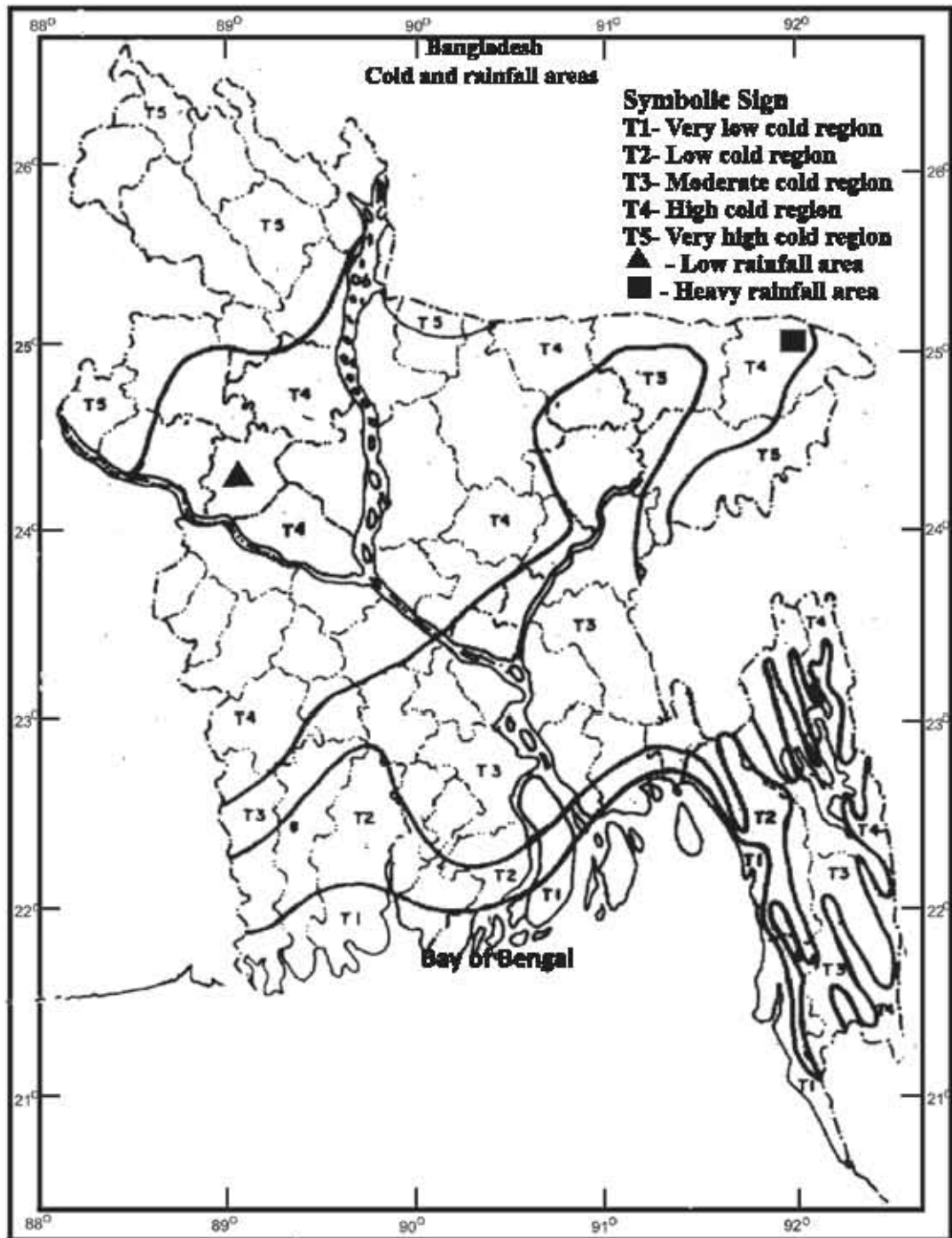

Figure : Different regions according to the intensity and duration of coldness in Bangladesh and rainfall areas in Bangladesh

2. **Rainfall** : Rainfall varies largely according to regions in Bangladesh. The annual average rainfall is 1100 to 4500 millimetre. About 90 percent rainfall occurs during April - August. There is a little rainfall in winter. The quantity of rainfall increases from the west to the east in the country. The highest rainfall is in Lalpur, Natore and the lowest in Lalakhal, Sylhet.
3. **Humidity** : Humidity differs quiteley with the change of seasons. The air has little vapour in winter. The air is quite humid in summer and rains. The humidity in the air is related with rainfall. The average comparative humidity of the air in winter is from 73% to 84%. It remains 83% to 89% in rainy season. Bangladesh frequently faces natural calamities like heavy downpour, shortage of rainfall, drought, flood, cyclone, etc.

Lesson-4 : Agro-ecological zone based on soil, water and climate

Soil, water and climate differ in different regions in Bangladesh. For this variation, one particular type of crop grows well in one special area. Bangladesh is divided into 30 agro-ecological zones on the basis of soil, water and climate. This classification is made considering soil type, fertility, nature of crop growth, level of water in the land during flood, tenure of crop growth in an area, rainfall and temperature. The names of 30 agro-ecological zones are given below:

1. Old Himalayan piedmont Plain Land Area, 2. Active Testa-flooded or inundated Land Area, 3. Testa meander flooded Land Area, 4. Korotoya-Bangali flooded Land Area, 5. Lower Atrai basin Area, 6. Lower Punarvaba flooded Land Area, 7. Active Bramhaputra and Jamuna flooded Land Area, 8. Young Bramhaputra and Jamuna flooded Land Area, 9. Old Bramhaputra flooded Land Area, 10. Active Ganges flooded Land Area, 11. High Ganges river flooded Land Area, 12. Low Ganges river flooded Land Area, 13. Ganges tidal flooded land area, 14. Bil areas of Gopalganj-Khulna, 15. Arial bil Area, 16. Middle Meghna river flooded Land Area, 17. Lower Meghna river flooded Land Area, 18. Young Meghna estuarine flooded Land Area, 19. Old Meghna estuarine flooded Land Area, 20. Eastern Surma-Kushiara flooded Land Area, 21. Sylhet Basin Area, 22. Northern and Eastern Piedmont Plain Areas, 23. Chittagong Coastal Plain Land areas, 24. St. Martins Coral Island Area, 25. Plain Barind Tract, 26. High Barendra Area. North-eastern Barind Tract, 28. Madhupur Area Tract, 29. Northern and

Eastern Hilly Area, 30. Akhawara Terrace.

Task : Classify the agro-ecological zones into 5 larger categories in the map of Bangladesh and present them in your classroom.

New Word: Agro-ecological zone.

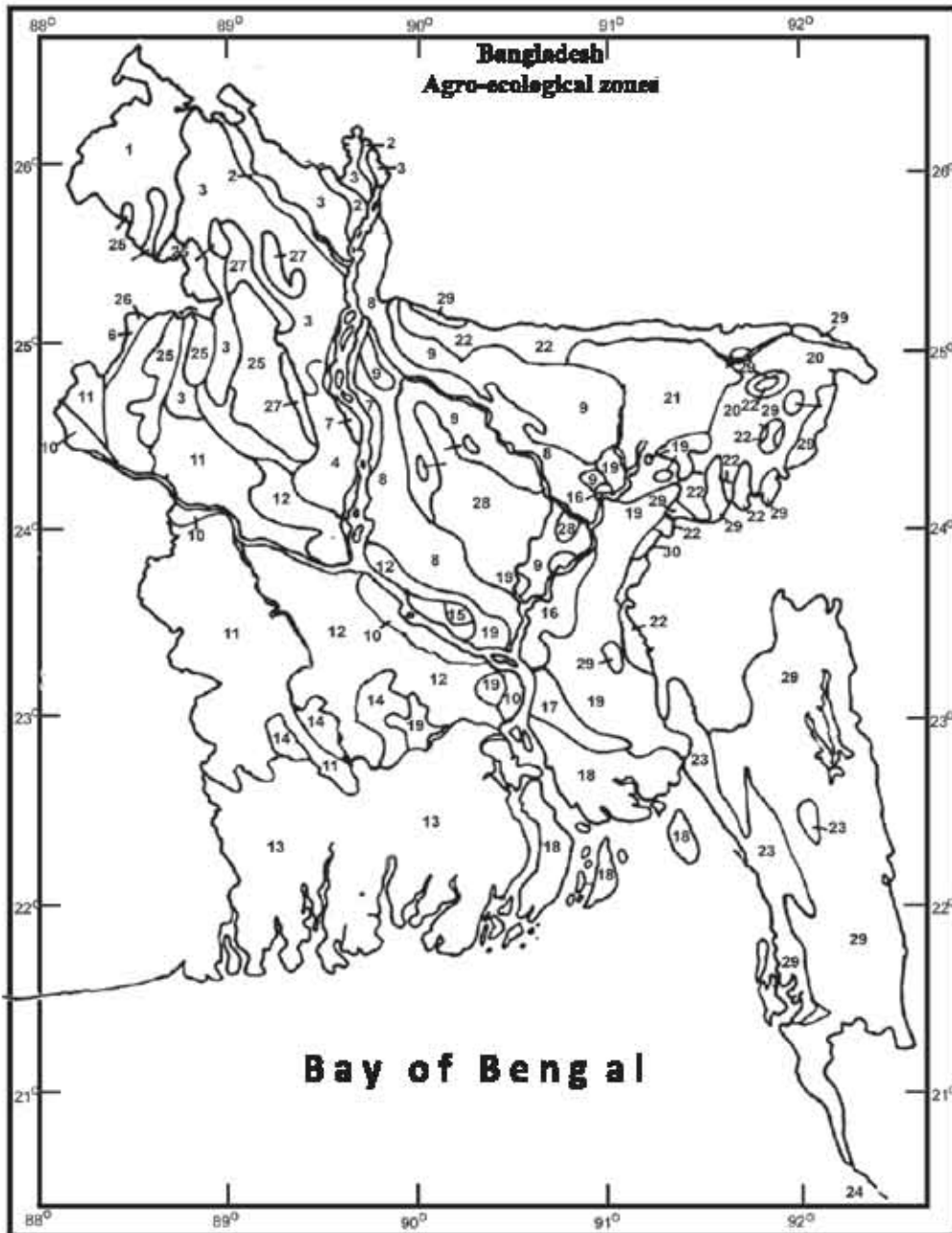

Figure : Map of Bangladesh's agro-ecological zones

Lesson-5 : Flood, cyclone and drought prone areas in Bangladesh

Flood : Flood is a water-created natural calamity. Four kinds of floods are seen in Bangladesh, such as :

1. Flash or sudden flood : This sort of flood is seen in the northern and the eastern hilly basins in Bangladesh. This flood is caused suddenly in the months of April and May for the border hilly swell. The water of this flood lasts from a few hours to several days. Crop damage often happens for sudden floods when paddy ripens in the marshy or haor areas.

2. Flood caused by rain : This flood is seen when the low-lying areas of the country are submerged due to heavy downpour. This sort of flood is seen in the northern, western and mid areas of the country.

3. River-borne flood : When heavy rainfall continues in the upstream regions of Bangladesh, the water flows to the Bay of Bengal from all over the country. As our major rivers are filled with silt, they fail to transport the huge amount of water quickly. As a result, flood occurs in the central portions namely the basins of the Padma, the Meghna and the Brahmaputra. Devastating floods occurred in these areas in the years of 1988, 1998 and 2004.

4. Flood caused by coastal storms and cyclones : Cyclone occurs when a violent depression is created in the Bay of Bengal. A wind-storm is accompanied with a tidal surge in coastal areas. The salty water of the sea rushes towards coastal areas at a great speed standing high and causes floods. So crops, fisheries, livestock, houses are damaged with the loss of human lives. For example, the last Sidor and the Aila caused a havoc in the southern areas of Barisal and Khulna divisions.

Drought : If rainfall does not occur continuously for 20 days or more than that in dry season, this condition is drought. Due to drought there is deficiency of moisture in the soil for crops. So that crop yield may decrease 15 to 90%. The most drought prone areas in Bangladesh are Rajshahi, Chapainawabgonj, Naogon, Dinajpur, Bogra, Kushtia and Jessore.

<p>Task : Identify flood, tidal surge and high drought prone areas in the map of Bangladesh.</p>

New Words: Sudden or flash flood, flood caused by rain, river-borne flood, flood caused by coastal storms and cyclones, drought prone area.

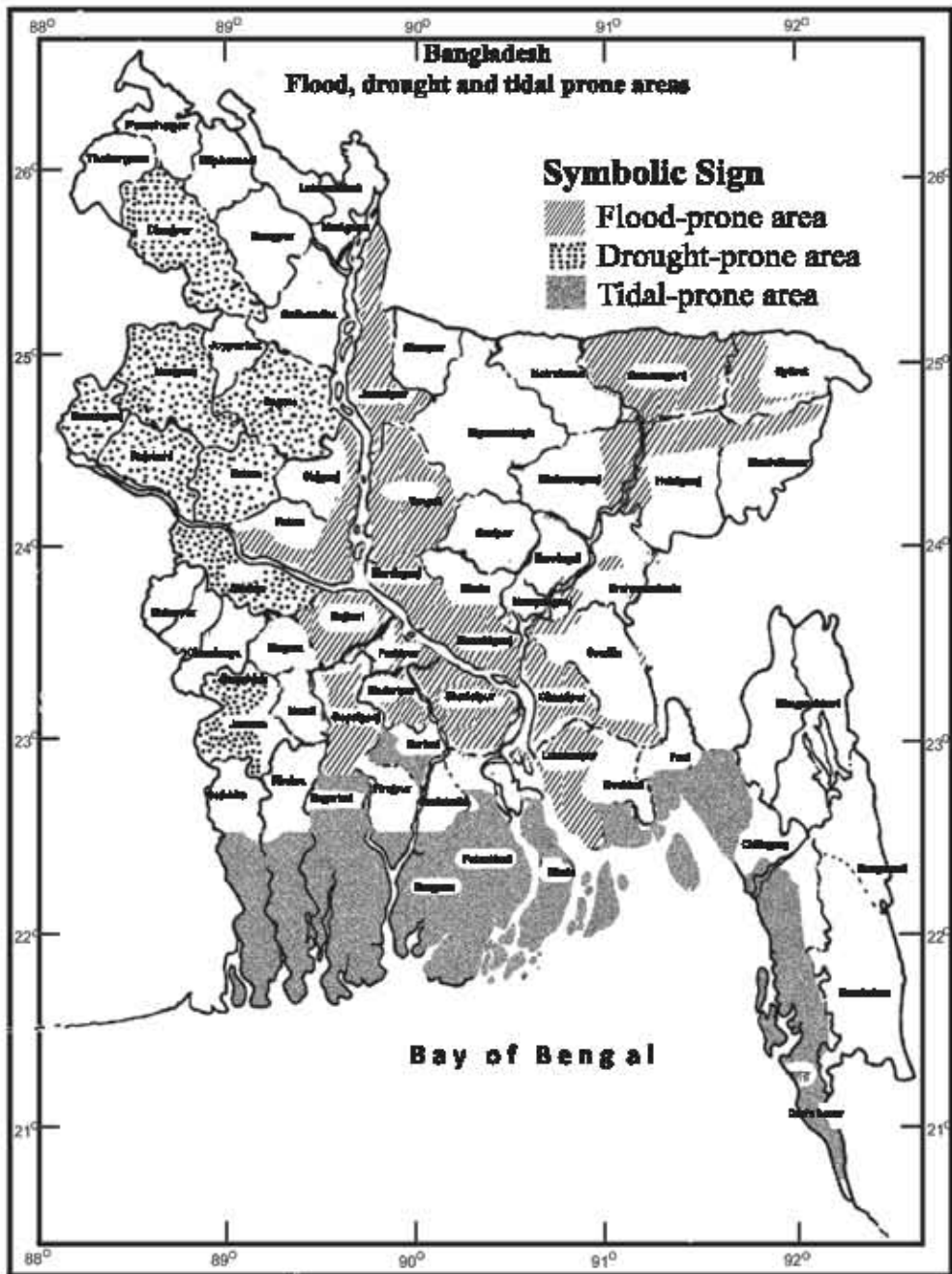

Figure : Map of flood, drought and tidal prone areas in Bangladesh.

Exercise

Fill in the blanks

1. The average of weather of the duration of years of a place is called the climate of that place.
2. The quantity ofin the air is called humidity.
3. Rainfall in Bangladesh is influenced by climate.

Match the left column with the right column

Left column	Right column
1. The climate of Bangladesh	greenhouse effect.
2. Weather	rainfall.
3. Climate change	elements of weather.
4. Temperature, rainfall, humidity etc.	equable.
5. The increase from the west to the east in Bangladesh	changing on a daily basis.

Short answer questions

1. How many agro-ecological zones is Bangladesh divided into?
2. How many kinds of floods occur in Bangladesh?
3. How is the form of rainfall in Bangladesh?

Descriptive questions

1. Describe the elements of climate.
2. Mention the importance of weather and climate in agriculture.
3. Draw the map of Bangladesh and mark 3 agro-ecological zones in Bangladesh.

Multiple choice questions

1. Which one of the following is the element of weather?

a. Ocean current	b. Solar radiation
c. Rainfall	d. Topography.

2. Climate -

- i. slowly changing
- ii. influenced by the monsoonal wind blow
- iii. influences upon the qualities of the soil

Which one is correct?

- a. i & ii b. i & iii
- c. ii & iii d. i, ii & iii

Read the following passage and answer the questions 3 and 4

Moutosi went to visit their village home with her mother and found that her uncle was cultivating lentil and linseed in his land.

3. In which season did Moutosi go to visit?

- a. Rainy season b. Summer
- c. Winter d. Autumn

4. How will be the condition of the climate at that time?

- a. less vapour and rainless
- b. enough heat and sufficient rainfall
- c. sudden storm and cyclone
- d. depression in the sea and cyclone

Creative questions

1. Joyonta Sen cultivates different types of vegetables in his kitchen garden. His daughter, Koyel chose to sow some mustard seeds there in the month of Chaitra. Though the seeds germinated, the seedlings died after several days. But the vegetables such as snake gourd, pointed gourd that his father sowed grew well. When Koyel asked Joyonta Sen about the matter, he said that the knowledge of seasons about crop cultivation was very necessary.

- a) What is climate?
- b) Explain that land cultivation is dependent on rainfall.
- c) Describe the reason why Koyel's sown seedlings died.
- d) Analyse the opinion of Koyel's father about crop cultivation.

2. Sadia went to visit her maternal uncle's house. Which was located in an industrial area. The area was densely populated, and there were nothing else except high-rise buildings and vehicles. She began to feel uncomfortable in the extreme heat. She felt pain to breathe. Later her father discussed the matter with Mr. Anwar, an environmental expert who said that the unawareness of the inhabitants of that locality was responsible for the situation.

- a) When is the highest temperature of Bangladesh found?
- b) Explain that humidity is the cause of the rainfall.
- c) Describe the reasons of Sadia's feeling of discomfort in her maternal uncle's house.
- d) Opine how Sadia's maternal uncle's area could be saved from environmental pollution.

Chapter Five

Agricultural Production

Agricultural production means the production of crops, animals-birds and fishes. The introduction, characteristics and economic importance of horticultural and field crops, domestic animals and birds, and cultivable fishes have been discussed in this chapter. Side by side, methods and techniques of vegetables production (Red amaranth (lalsak), tomato and pepper), bird rearing (Pigeon) and fish cultivation (Pangas) have been described.



Figure: Tomato

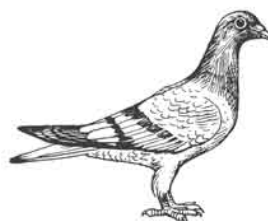

Figure: Pigeon



Figure: Pepper

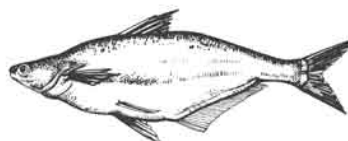

Figure: Pangas

At the end of this chapter, we will be able to :

- describe the characteristics and economic importance of horticultural crops.
- describe the characteristics and economic importance of field crops.
- describe the production method of vegetables.
- describe the characteristics and economic importance of cultivable fishes.
- describe the method of fish cultivation or pisciculture (Pangas.)
- describe the characteristics and economic importance of domestic animals and birds.
- describe the method of bird rearing.
- grow agricultural products (vegetables) in homestead.
- be interested in growing agricultural products.

Lesson-1: Introduction and economic importance of horticultural crops

The plants that man grows for his necessity are called crops. Crops are divided into two major categories such as horticultural crops and field crops. The word 'horticulture' means 'garden'. We make garden of different crops such as fruits, flowers, vegetables, etc. in high lands around our homestead. The crops we grow in a garden are called horticultural crops. At present horticultural crops are commercially grown in the fields. Horticultural crops are divided into four types, such as :

1. Fruits: Mango, jack-fruit, litchi, guava, jujube, wood apple, etc.
2. Vegetables: Potato, brinjal, tomato, bean, bottle gourd, spinach, etc.
3. Spices: Pepper, onion, ginger, turmeric, etc.
4. Flowers: Marigold, china rose, togor, beli, cosmos, dahlia, etc.



Figure: Jack fruit



Figure: Mango



Figure: Litchi



Figure: Cauliflower



figure: Garlic



Figure: Rose

Task: Make a list of fruits, vegetables and flowers which are grown in Bangladesh.

Horticultural crops have some special characteristics that make them separate from other crops. Horticultural crops can be cultivated intensively on small scale. That is to say, the cultivation of these crops does require more capital and labour in a unit-area. These are cultivated to meet man's food and medicine requirement and to satisfy his thirst for beauty. The horticultural crops cultivated for food have more vitamins and minerals. These are usually eaten fresh and

most of them are juicy and perishable. The external appearance and taste of these crops are very important to men.

We ourselves can understand the importance of horticultural crops after knowing their characteristics. More profit from less land is the main economic characteristic of horticultural crops. The importance of horticultural crops can be easily understood from the following subjects.

1. **Nutrient and Importance in families :** According to World Health Organization, a man should eat daily 450 gm of vegetables and fruits. The demand of food and nutrition of a family can be met by cultivating horticultural crops around the homestead. Again the income of a family can be increased by selling excess crops. On the other hand, valuable wood is obtained from the fruit-bearing trees of mango, blackberry, jack-fruit, etc. This wood is used in building houses and making furniture. A huge amount of money is got by selling wood. Moreover a lot of firewood is collected by pruning off the branches of fruit-bearing and ornamental plants. This firewood is used in the cooking of a family. As a result, money is saved in energy sector.
2. **Economic Importance:** Garden crops have a tremendous demand at home and abroad. We can earn more from vegetables, fruits, flowers by applying modern methods of cultivation. On the other hand, intensive nursing is needed in the cultivation of horticultural crops. More capital, labour and technology are required at every level from production to marketing. So opportunities of employment are created all round the year. As a result, unemployment problem is solved. Moreover, fruits and vegetables such as mango, pine-apple, tomato, guava, litchi, potato, banana, etc. can be processed to make jam, jelly, prickle, juice, sauce, chips and these can be sold at a high price. Small and medium industries can be developed to make these items.

New Words : Horticultural crops, field crops.

Lesson-2 : Introduction and economic importance of field crops

We have come to know about horticultural crops in the previous lesson. We will know about field crop in this lesson. Field crops are divided into six types on the basis of their use, such as:

1. Cereal crop: Paddy, wheat, maize, etc.
2. Pulse crop: Lentil, green-gram, chickpea, pigeon-pea kesari, etc.
3. Oil crop: Mustard, sesame, sunflower, etc.
4. Fibre crop: Jute, cotton, kenaf, etc.
5. Sugar crop: Sugar-cane, sugar-beet, etc.
6. Cattle Feed (Fodder crops): Cow pea (Felon), guinea, para and napier grass, etc.



Figure: Paddy



Figure: Gram or chick-pea



Figure: Sunflower



Figure: Carpus cotton



Figure: Sugar-beet



Figure: Napier Grass

Field crops have some special characteristics that make them separate from horticultural crops. Field crops are cultivated at a large scale. It does not require intensive cultivation like that of horticultural crops. These are cultivated as human and animal feed. It is quickly perishable.

As we are introduced to field crops, we can certainly assume their economic importance. Cereal, pulse and oil crops are our food crops. Paddy, wheat, maize are used as the main human foods among cereal crops. Pulse crops meet the demands of our protein. We get edible oil from different oil crops.

Wheat, maize and pulses are used as foods for animal and feed for birds and fishes. Para, guinea, napier, pigeon-pea are cultivated as cattle feed. These are fed in green condition. As a result, animal and bird raising, and fish cultivation have commercially expanded.

Sugar is made from sugar-cane and sugar-beet. Sugar-cane cultivators in our country earn ready cash by supplying sugar-cane to sugar mills.

Thread, cloth, rope, sack, carpet etc. are made from fibre crops. Among the fibre crops jute is one of the greatest ones in our country. Jute and jute-made products have huge demand at home and abroad. We earn a lot of foreign currency by exporting jute and jute-made products.

Task : Write down the name of some field crops that have not been mentioned here and explain their uses.

New Words : Cereal or grain crop, fibre crop, fodder crop.

Lesson-3 : Red amaranth (red herb) cultivation method

Red amaranth is a popular vegetable in our country. Red amaranth is cultivated more or less almost everywhere in Bangladesh. It contains a lot of vitamins.

Soil : Red amaranth is cultivated in almost all types of soil all the year round. However, loamy and sandy-loamy soil is best for its cultivation. The production of red amaranth in our country is abundant at the outset of winter. Red amaranth can be cultivated in high land during summer .

Variety : There are many varieties of red amaranth. However two improved varieties are Altapati and BARI Lalsakh-1. The leaves and stem of Altapati variety are vermilion red. The leaves and stem of BARI Lalsakh are red. The flower of this amaranth is red and its seed is round in shape.

Land preparation : The seed of red amaranth is very small. So the land is prepared loose by ploughing 4-5 times and laddering. Red amaranth is a short duration crop. So 40 kg of cow-dung, 400 gm of Urea, 300 gm of TSP and 250 gm of MOP fertilizers have to be applied per decimal land. After seven days of seed germination, an amount of 400 gm extra urea fertilizer per decimal land will be top dressed and mixed with the soil.

Seed Sowing : The seeds of red amaranth are sown by broadcasting and in lines. If sown in lines, nursing is convenient and there is more yield. A 1m wide and 15 cm high seed-bed is prepared to sow seeds in the rainy season. A 30 cm irrigation drain is to be kept between two seed-beds. There may be an equal distribution of seeds everywhere, if seeds are mixed with sand at the time of sowing. 10 gm of seeds is enough per decimal land. If sown in lines, with the help of stick making 1.5-2.0 cm deep line having 20 cm distance then seed should be broadcast in lines and the soil should be levelled.



Figure : Red Amaranth

Inter cultural operation : The nursing that is taken from seed-sowing or seedling-planting to crop-harvesting is called inter cultural operation. No irrigation is necessary, if there is sufficient moisture in the soil at the time of sowing. But if there is not sufficient moisture in the soil, irrigation is necessary. When seeds germinate, seedlings should be kept 5 cm apart in the rows and other plants must be lifted as thinning out within a week. The weed must be cleaned out by weeder and the soil should be mulched after irrigation.

Crop harvesting : Red amaranth can be collected after 20-25 days of sowing seeds. Firstly tall plants need to be lifted. Thus amaranth can be lifted after two or three days of interval. The plants of red amaranth is lifted with roots. Then they are washed away, tied in bundles and marketed. Crop harvesting should be completed for leafy vegetables before the stem becomes hard.

Yield : 45-55 kg red amaranth is obtained from per decimal of land if improved method of cultivation is applied.

Task : Make a list of agricultural materials needed for cultivating red amaranth in five decimal land.

New Words : Top dressing, cultivation in bed, soil moisture availability, inter intercultural operation.

Lesson 4 : Pepper cultivation method

Pepper is a spice crop in Bangladesh. Green and red peppers are used for hot taste or pungency. Green chilli contains more vitamin C. Now-a-days a kind of pepper is found which is less hot. This is called capsicum. This pepper is used as salad.

Variety : There are many breeds of peppers existing in different areas of Bangladesh; such as Bindu, Challissa, Dhani, Ubda, Chittagong, Comilla, Bogra, etc. Moreover, an approved variety named Bangla Lanka (Bari Pepper-1) is suitable for cultivation round the year.



Figure: Hot pepper

Soil : Pepper grows well in sandy-loam and clayey-loamy soils with drainage facilities. However, loamy and silty-loamy soils, rich in compost, are the best for pepper cultivation. Pepper plant cannot tolerate water logging condition.



Figure: Capsicum

Sowing time : The proper time for sowing seeds is September-October months in the robi season. Seeds are sown in seed-beds in the kharif season starting from the first week of December to the first week of February. When a seedling shoots out 4-5 leaves, it becomes suitable to be planted in the field.

Seed rate, Sowing and Plantation distance: 12-16 gm seeds are required per decimal land, if seeds are sown directly in the main field. Half of the seeds are required if seedlings are developed in seed-beds. The seedlings are kept 25 cm apart from row to row and the plants should be kept 20 cm apart in the robi season. In the kharif season, seedlings are to be planted 45x45 cm apart in main field.

Seed-bed preparation : Seeds are usually sown directly in the main field during robi season and during kharif firstly seedlings are raised in seed-bed then they are planted in the main field. The size of seed-bed is kept 3 m x 1 m (Length x width) and it is kept 15 cm high. The top soil of the seed bed is made loose with the mixture of sand, soil and cow-dung in a proportion of 1: 1: 1. Treated seeds are sown 5 cm apart and 2-3 cm in-depth. Sevin dust is sprayed around the seed-bed to protect seeds from ants. Seeds germinate within 7-10 days. The seed-bed is covered with polythene or straw shed after sowing seeds in order to protect them from heavy rain or strong sunlight. The seed-bed is to be irrigated slightly either in the morning or in the evening according to necessity. When a seedlings grows 4-5 leaves, it becomes suitable for transplantation in the field.

Land preparation and fertilizer application: The land is to be prepared well by 4-6 time ploughing and laddering. 40 kg of cow-dung, 1200 gm of TSP and 540 gm of MOP, 440 gm gypsum fertilizers have to be mixed with the soil per decimal land at the time of last plowing. The seed-bed is to be made 1m in length and width on the basis of the area of the land to direct sow seeds or to plant seedlings. The seed-bed is to be 15 m high and there should be a 30 cm drain between two seed-beds for irrigation and drainage facilities.

Inter cultural operation: The land must be always kept weed-free. Urea and MOP fertilizers will be applied dressing top thrice after 20, 40 and 60 days of seedling plantation. Every time per decimal of land 280 gm urea fertilizer mixed with the soil needs to be spread from the base of the seedlings at a distance of 10-15 cm apart. Irrigation is needed in winter and drought period. Again irrigation is necessary after every installment of fertilizer application. If saw crock is formed on the soil after few days of irrigation, that should be broken.

Task : Make a poster about the seed-bed of pepper.

Lesson- 5 : Disease and insect pest control of pepper

Disease Control : Damping-off disease may occur when a pepper plant is in a seedling stage. To control this disease, 1 kg seeds need to be mixed with 03 gm Provex for the treatment of the seeds. The seed-bed should be kept dry. Sometimes a pepper plant dies getting dried gradually from the top to the bottom. This is called Die-back disease. To control this disease, spray 1gm Bhavistin mixed in 1 litre water 2-3 times at an interval of every 15 days. To prevent yellow mosaic virus, the affected trees have to be uprooted immediately and then burnt. Peppers varieties that are disease resistant should be cultivated.



Figure: Blight disease of pepper

Insect pest control : The leaves of seedlings get wrinkled by the attack of tiny spiders. Such spiders can be controlled with the spray mixture of 2 gm of Theovit in 1 liter water, after every 10 days. If the seedling are attacked with thrips and aphids, the spray mixture of Malathion 50 EC 1 ml in 1 liter water will give a good result. Insecticides or fungicide should rather be avoided at the time of crop harvesting. If it is to be used, crop harvesting should be stopped for 5- 7 days.



Figure: Nymph of aphids

Crop harvest : Flowers start to bloom after 30-40 days of planting seedlings. Green peppers need 25-30 days to be matured. More than 25-30 days are required for the peppers to ripen. Green peppers can be collected 2-3 times within a week and red peppers are to be collected after every 15 days up to about 2-3 months.

Yield : The yield varies in accordance with variety. On an average 6-10 tons yield can be produced per hectare land. But 1.5-2.5 tons dried peppers can be obtained per hectare land.

Pepper cultivation method in a tub :

So far we have learnt the pepper cultivation method in the field. Now we will learn how to cultivate pepper in a tub. If we want to cultivate pepper in a tub, first we need an earthen tub or a plastic tub of 6-10 inch diameter. To prepare the soil of the tub, we need to mix loamy soil, sandy soil and cow-dung in 1: 1: 1 ratio. Then we need to place a piece of pot or pitcher or brick upon the bottom

hole of the tub. So that the excessive water can be leached away. Now the tub is to be filled with the mixed soil. Then the seedling is to be planted on the prepared tub and water is to be lightly sprayed with a watering cane. The tub is to be placed where it may get sunlight for at least 6- 7 hours in whole days. However, the tub should be kept in the shade at noon for the first few days of seedling plantation.

It is better to use compost or cow-dung in the tub in case of pepper cultivation. If there is deficiency of fertilizer, the surface soil of the tub becomes white and the scarcity of moisture in the soil is seen. If it happens, that the soil of the tub is to be made loose, with weeder and fertilizers are to be mixed. Irrigation is to be performed in such a way that water does not get stagnant. Frequent irrigation makes the soil of the tub hard. So the soil is to be made loose a few days after interval with weeder.



Figure: A perforated earthen tub



Figure: A pepper plant with tub

Task : Make a list what kind of vegetables can be grown in a tub.

Lesson-6 : Tomato cultivation method

Tomato is a kind of vegetable rich in vitamins A, B and C. Green and ripe tomatoes are used in cooking and ripe tomato is popular as salad. Moreover, sauce processed from ripe tomato is appetizing. Tomato is primarily a winter vegetable. But today it is also cultivated in summer.



Figure : Tomato plant



Figure: Tomato harvesting

Breed : There are many approved varieties of tomatoes in Bangladesh. Bari tomato-2 (Ratan), Bari tomato-9 (Lalima), Bari tomato-10 (Anupama), Bari tomato-3 are among winter varieties and Marglobe, Ruma VF, Oxheart are among imported varieties from abroad. Bari tomato-4, Bari tomato-5, Bari tomato-9 (Lalima), Bari tomato-10 (Anupama), Bari tomato-11 (Jhumka), Bari hybrid tomato-3, Bari hybrid tomato-4 are among summer varieties.

Soil : Fertile loamy soil with light and air is most suitable for tomato cultivation. However, tomato is grown well in all types of the soil from sandy-loamy soil to clayey-loamy soil, if proper nursing is ensured.

Seedling production method: 200 gm seeds is required in a hectare of land for tomato cultivation. First each 50 gm seeds is densely sown in 4 seed-beds (3 metre x 1 metre). When seeds germinate, seedlings are planted 4x4 cm apart in a second seed-bed after 8-10 days. In that case, 22 seed-beds are required. Thus strong seedlings are found. The proper time for sowing winter-variety is September-October months.

Land preparation and fertilizer application: The land is to be made loose by 4-5 times ploughing and laddering. On the variation of soil, nature and geographical location, a 1 metre wide and 15-20 cm high seed-bed is to be prepared. A 30 cm wide drain is to be kept between two seed-beds for suitable irrigation and drainage. Fertilizers for tomato cultivation are to be used as follows:

Name of fertilizer	Quantity of fertilizer/ Decimal
Urea	2.0-2.5 kg
TSP	1.5-2.0 kg
MOP	0.8-1.2 kg
Cow-dung	30-50 kg

Before the final ploughing, cow-dung, TSP and two-thirds MOP fertilizer are to be mixed with the soil properly. Urea fertilizer is to be applied in three equal installments after 10, 25 and 40 days of seedling plantation. The rest of the MOP fertilizer is to be divided into two and used after 25 and 40 days.

Seedling transplanting: When the seedling becomes 30-35 days old, it becomes suitable for plantation. The seedlings need to be uprooted from the seed-bed with care so that the roots of the seedlings are not damaged. So the soil of the seed-bed needs to be soaked in water before uprooting. It is better to plant the seedlings at the setting sunlight of the afternoon. Light irrigation is

necessary after the transplanting. Seedlings need to be transplanted in two rows in one metre wide seed-bed. The distance between rows should be 60 cm and the distance between seedlings should be 40 cm.

Inter cultural operation : The land must be kept weed-free. It is lightly irrigated the first 3-4 days of the seedling transplanting. Later if the soil is deficient in moisture, it is necessary to irrigate the land. If extra water is stagnant in the land due to irrigation or rain, the water needs to be drained out. The tender portion under the bunch of the first flower must be kept and the other tender portions of the side must be pruned. The plant is to be supported by a post of bamboo.

Task: Make a list of vegetables that can be cultivated in a homeyard.

Lesson-7 : Disease and pest control of tomato

Damping off disease : The bottom of the seedling is drenched with watery spots and gets rotten. Sometimes the root gets rotten and the seedling dies. The soil is drenched with Ridomil gold and applied in the affected place.

Wilting disease : The plants wilt downwards any time and dies quickly in this bacterial disease. The affected plants need to be burnt on spot. The resistant variety are to be cultivated.



Figure : Wilting disease

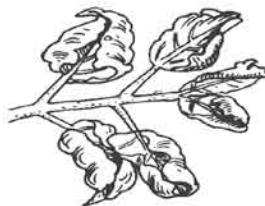

Figure : Yellow leaf curled disease

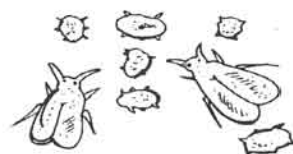

Figure : White fly

Yellow leaf curled disease : The leaves get wrinkled from the edge to the midrib in this fungal disease. The leaves become dry, the veins get wrinkled and transparent yellow. The small leaves at the shoot of the affected plants become clustered. To control this disease, the tomato field needs to be weed-free, disease-free seedlings need to be planted and the affected plant has to be removed and burnt. White fly insects quickly spread this disease. To prevent fly insects, an insecticide named Admayar is to be sprayed at an interval of 7-10 days

Crop harvesting : Tomato starts to ripen after two months of seedling transplanting. The duration of tomato is 120-150 days depending on their varieties. When the tomato becomes reddish in colour, the fruit is collected by cutting the stalk. Production varies depending on their variety or seasons. The production is about 250 kg/ decimal in winter and it is about 80-100 kg/ decimal in summer.

Task : Plant yourself a tomato seedling in a tub or a yard, nurse regularly and inform your teacher about the advancement.

Lesson-8 : Introduction of cultivable fishes in Bangladesh

We eat one or another kind of fish every day. Fish is our very favourite food. Fish is one of the most important natural resources in Bangladesh. A lot of fishes are found naturally in the sweet water of our rivers, canals, marshes, ponds and lakes such as rui, katla, mrigela, shingi, punti, khalisha, koi or climbing fish, chitola, boal, shrimp etc. On the other hand, there are different kinds of fishes in the Bay of Bengal, a huge source of our saline water fish. Such as, hilsa, rupchada, loitka, coral etc. But our quantity of production of fish is much less than people's demand. The demand of fish is increasing everyday with the increase of the population of the country. So we can meet the demand by cultivating more fish.

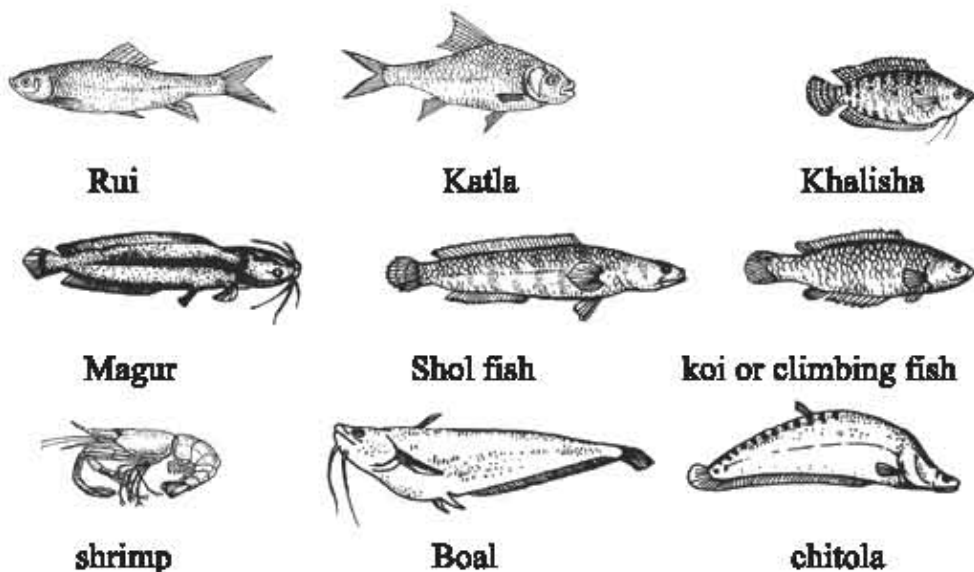
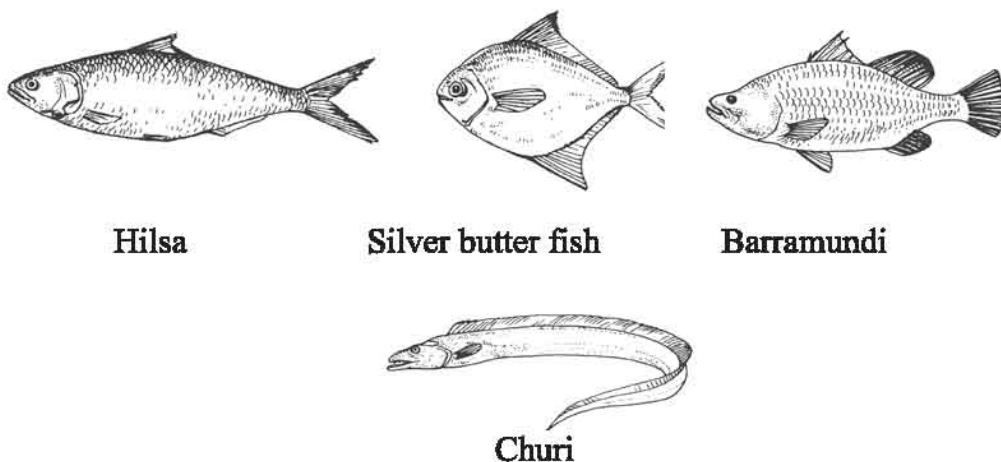

Figure : Some of the sweet water fishes in Bangladesh



Hilsa

Silver butter fish

Barramundi

Churi

Figure : Some of the saline water fishes in Bangladesh

Fish is a vertebrate animal. They breathe with gill and move with tail and fin. The body of the fish is fat and it is slim towards head and tail. So they can move easily and quickly in the water. Shrimp is an invertebrate animal. Shrimps live in water and they are delicious to eat.

We cannot cultivate all the fishes in the pond that are found in Bangladesh. The local cultivable fishes such as rui, katla, mrigela, kalivaush, lobster and prawn are remarkable. Besides local fishes, some exotic fishes have been brought to our country for cultivation. These fishes are cultivated individually or with local fishes in a pond as mixed cultivation. Among the exotic cultivable fishes, there are Thai pungas, silver carp, grass carp, Thai sorputi and telapia.

Task : Make a list of cultivable fishes and present them in class.

New Words: Sweet water, Saline water, gill, mix cultivation.

Lesson-9 : Characteristics of cultivable fishes in Bangladesh

Though many kinds of fishes are found in Bangladesh, all of them cannot be cultivated in ponds. The fishes, whose young ones are easily available, grow quickly, have demand and fair price in market, are nutritious and tasty to eat are cultivated in the pond. Moreover, these fishes can digest efficiently the natural food of the pond and the supplementary food provided from outside.

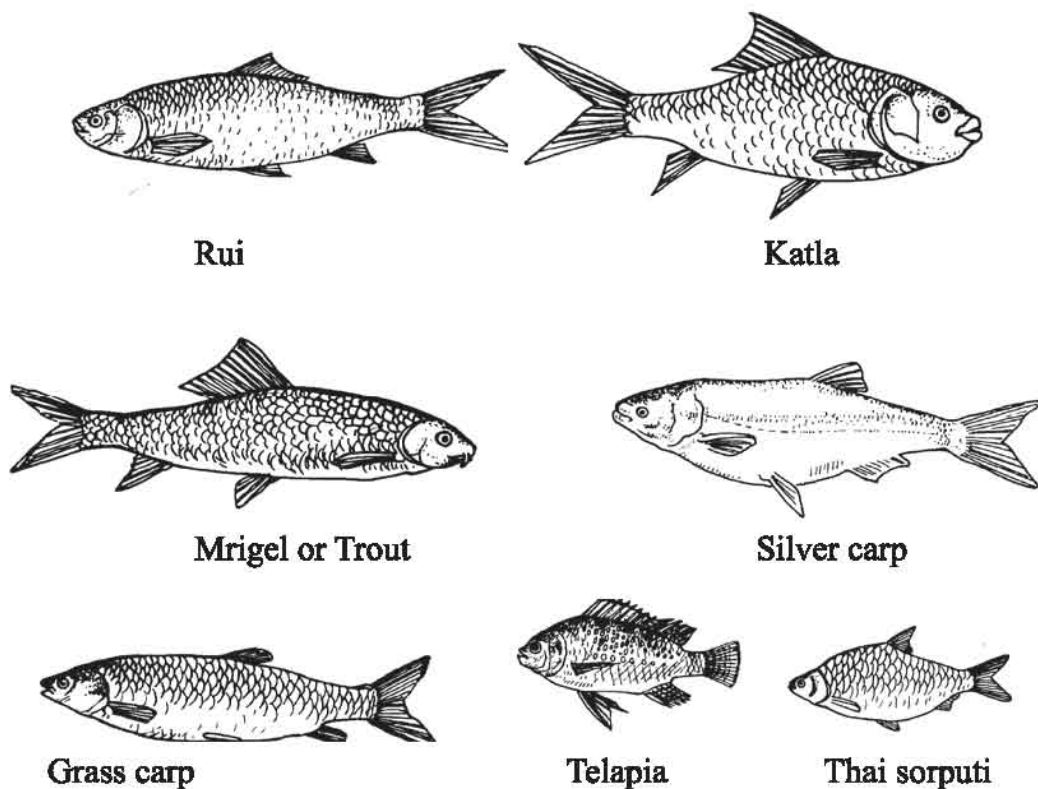

Figure : Some major fishes cultivated in ponds

The main cultivable fishes in our country are rui, katla and trout. These are all riverine fishes. But they are very suitable for cultivation in the pond. Besides natural food, they eat supplementary food. They lay eggs in the flowing river in the rainy season. However, now-a-days young fish or pona is hatched in the hatchery for the purpose of fish cultivation. Their physical characteristics are described below:

Rui : Its body is long. The head is comparatively small. The lip is swelled up

and there are many delicate wrinkles at the edge of the lip. The back is quite brown. The belly is light golden. It becomes 1 kg within a year.

Katla: Its head is big, the body is wide and a bit subdued. The back is high, the mouth is bent upwards. This fish grows very quickly. If they are properly fed, they can be 4-5 kg within two years.

Mrigel : The head is smaller than the body. The mouth is slightly downwards. The body is long, the lower portion is longitudinally straight. They have two pairs of small antennas by the two sides of the mouth.

The exotic fishes that can be cultivated in the pond are silver carp, grass carp, tilapia, Thai sorputi and they are today cultivated widely. Their characteristics are described below:

Silver carp : They are river water fish of China and Russia. Their head is small, the middle portion is wide, the front and the back side are narrow. The scale is very small. The colour of the body is glittering silvery. Their mouth is bent upwards like the katla fish. This can be cultivated in the pond with the local cultivable fishes. Silver carp grows the quickest of all the exotic fishes that can be cultivated in ponds.

Grass carp: They are also found in the rivers of China and Russia. Their body is quite long, the head is small. The colour of the body is whitish and the fin is small. They grow quickly. Any grass or creeper can be fed during cultivation.

Telapia: They have been brought from Thailand. Telapia is very short and comparatively wide shape. The body is subdued and the colour is grey-blue. They are rapidly increasing and delicious to eat. They are individually cultivated in ponds. They become edible within 3-4 months.

Thai sorputi: This fish is also called royal puti or rajputi. The body colour of this fish is bright-silvery. The body is quite flattened. The head is quite small. They can be cultivated either individually or mixedcultivated with other fishes. They also become edible within 3-4 months.

Task : Present the characteristics of some of the cultivable fishes in a poster paper.

New Words: Supplementary food, hatchery.

Lesson-10 : Nutrition and economic importance of cultivable fishes

We can be economically benefited by fish farming. Fish is a very favourite food to everybody. We eat fish every day with other food items. Today the production of fish is very scanty in comparison to its demand. So we need to meet the nutrition demand of the family by fish farming in our water bodies. Moreover, we can earn ready cash by selling the excess produced fish in the market. The importance of fish is vital to meet our demand of nutrition, to create employment opportunities, to earn foreign currency and to ensure social development. The economic importance of fish is discussed below:

Fulfillment of the demand of nutrition: Fish is the main source of protein in our everyday menu. It is a delicious and nutritious food. Protein is necessary for our physical growth and prevention of diseases. A grown up man needs 33 gm to 66 gm of protein daily. Animal protein is the best among all proteins. But currently we eat less animal protein than required. The want of animal protein can be eradicated by increasing fish culture. So fish culture is very important.



Figure: Curry of rui fish

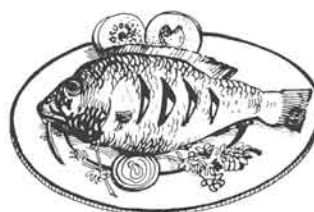

Figure: Tilapia fry

Task : Work in groups about the importance of fishes in fulfilling the demand of nutrition and present it in a poster paper.

Moreover, fish oil is beneficial to health. Small fishes of different breed such as mola fish, dhela, katchki fish have a lot of vitamin A. Vitamin A prevents night blind (nyctalopic) disease. The skeleton of fishes contains a lot of calcium and phosphorus that help to build the bone of the body.

Source of livelihood : About 15 million people in Bangladesh earn their livelihood in different ways from fishes; such as fish farming, catching fish and selling fish. The opportunities of employment are decreasing in our country as a result of population rise. The scope of employment can be created by fish farming.



Figure: Fishermen catching fish



Figure: vendors are selling fish in the market

Earning of foreign currency : Bangladesh is earning a lot of foreign currency by exporting fish abroad. 86% of the total earning in fish export comes from the export of prawn or shrimp or lobster. It is possible to increase this earning by increasing fish farming.

Socio-economic development : There are many shallow ponds, ditches and canals where fish is not cultivated. We can develop the economic condition of the poor and low-income people of the villages by arranging fish farming in these water bodies.

New Words: Water body, protein.

Lesson-11 : Importance of pangas cultivation and preparation of a pond for cultivation

Pangas is a favourite and tasty fish. Once there was abundance of pangas in our rivers. But today like other fishes, the availability of pangas has decreased for different reasons. Now-a-days pangas is imported from Thailand and is cultivated in our country. This fish has a great demand in the market.

Characteristics of pangas fish : The upper portion of the fish is brown and the belly is white. They have no scale on their body. The body is subdued, long shaped and the head is small. Pangas is very suitable for cultivating in ponds. This fish has no small bones. So it is very convenient to eat.

Benefits of pangas farming : Pangas can be cultivated in any sort of ponds, canals, ditches, and closed water bodies either big or small. This fish can be

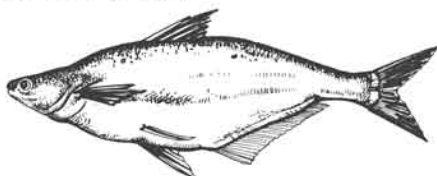

Figure : Yellow tail catfish (Pangas)

cultivated either individually or in a mixed way. As this fish is omnivorous, it can be produced more by providing supplementary food. The fry or fingerling is easily available from hatchery. Their power of preventing diseases and the rate of survival are more. So there are less risks in farming. This fish can be marketed in living condition by keeping them in little water.

Task: Make a poster about the importance of pangas and present it .

Pond preparation for cultivation : A pond needs to be prepared before the fry are released in the pond. The following steps are to be followed to prepare a pond –

- 1. Pond bank repairing :** Firstly the pond bank is to be repaired and high bank will be made. If there is any bush, we need to clear it up. If there is any big tree, its branches are to be cut off.
- 2. Cleansing the pond :** There should be no aquatic weed in the pond. If there is more clayey soil in the bottom of the pond, it is to be excavated. If possible, the layers of clay are to be dried and the pond bottom is to be made hard. Thus harmful gases and germs are removed.
- 3. Destroying carnivorous and unnecessary fishes :** No carnivorous and unnecessary fishes will be kept in the pond. This can be done by drying the pond through irrigation or by pulling dense string gill net. If the pond cannot be dried, 30-35 gm rotanon, a fish poison is used in a decimal for the depth of 30 cm water level and carnivorous fishes would be killed. The water of the pond cannot be used for 7-10 days after using rotanon. The fishes killed by rotanon can be eaten.

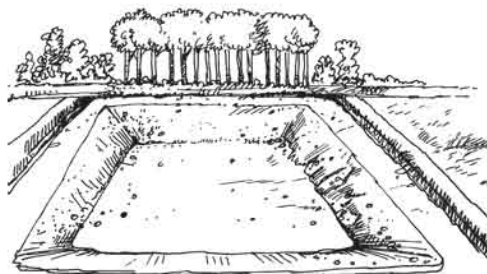

Figure : Catching carnivorous fish by pulling nets

Figure : A dry pond/ being prepared for fish farming

- 4. Application of lime :** When the above tasks are done, 1 to 2 kg lime is applied per decimal of the pond. The lime is first dissolved in a bucket or in a drum, and then sprayed on the pond. Lime makes the water clean and removes germs.
- 5. Application of fertilizers in the pond :** After 7 days of applying lime, 5-7

kg cow-dung or 2-3 kg poultry litter, 100-150 gm urea, 50-100 gm TSP fertilizer mixed with water are used per decimal of the pond. If the water of the pond becomes green after 5-6 days of fertilizer use, it is understood that the natural food is developed in the pond. Then the fry or fingerling is to be released.

New Words : Mixed culture, supplementary food, carnivorous fish, rotanon.

Lesson-12: Releasing pangas fry or fingerling, nursing of fish during farming and fish collection

Releasing fry or fingerlings : If the depth of the pond is 150-180 cm, 130-140 fry or fingerlings of 7-10 cm size is to be released in individual farming. In mixed culture, 120-125 fingerlings along with 4-5 silver carp or katla are to be released. After releasing fingerlings, care and nursing are to be given.

Application of food : Pangas is a rapidly growing fish. So food is to be provided after a specific time of interval in the pond. The balanced food bought from the market can be used in the pond. But the production cost will be more. So the food can be made in the farm instead of buying the marketed food. Ingredients for making 100 kg food for pangas are given below:

Serial no.	Food ingredient	Quantity (kg)
1	Dried fish dust	25
2	Oil cake	30
3	Wheat husk	20
4	Rice bran	20
5	Flour	3.50
6	Salt	1
7	Vitamin-mineral mixture	0.50
	Total =	100 kg

Every day 4-6% food is given in proportion to the total weight of the fishes in the pond. The daily food is divided into two and given in the morning and in the afternoon. But fingerlings should be given more food whereas the big fishes should be given less food.

Growth and health test of fish: When fingerlings are released in the pond, their growth and health should be taken care of. Every month the growth and health of the fish is to be examined by pulling nets. To control diseases and pest, 250 gm lime and 250 gm salt are to be used per decimal of the pond before summer and rainy season once a week for 4-6 weeks.

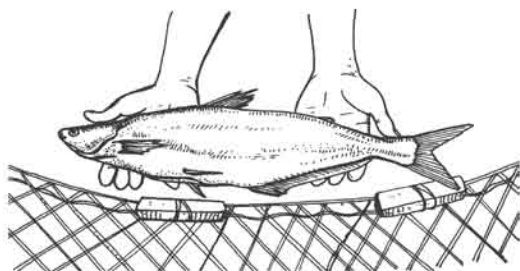

Figure : Health test of fish by pulling net



Figure : Catching fish from a pond

Fish catching and selling : A fish gains 500 gm weight on an average after 4 to 5 months of releasing a fry in a pond. If some fishes are caught and sold in market, the density of fishes will decrease. As a result, other fishes will grow quickly.

Task: Write down what to do about health test of fishes.

New Words : Mixed culture, vitamin-mineral mixture.

Lesson-13 : Introduction and characteristics of domestic animals

Many animals live in the world. Among them, cows, buffaloes, goats, sheep, horses, camels, etc. are reared in home by domesticating them and they give birth to their babies. So they are called domestic animals. Dogs, cats are also domestic animals like them. All of them are useful to us. There are about 24 million cows and 26 million goats in our country. Our local cows give 1 litre of milk per day. But foreign in hybrid cows give 15-20 litres of milk per day. Among the hybrid milking cows, Holstain Frisian Cow and Jersey Cow are mentionable.

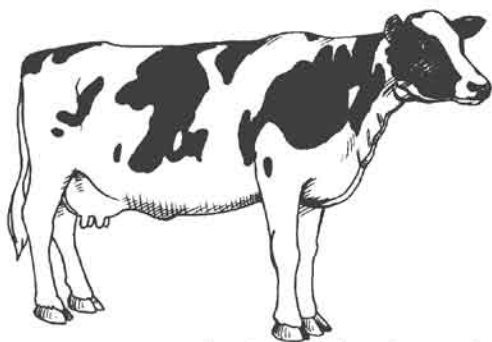

Figure : Holstain Frisian breed Cow

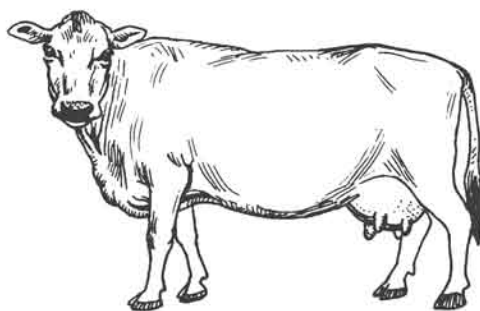

Figure : Jersey Cow

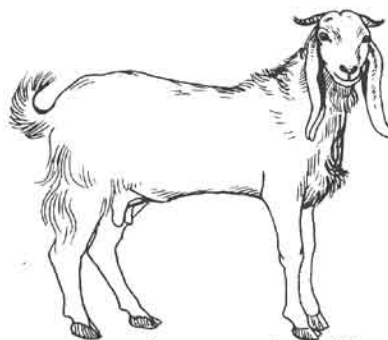
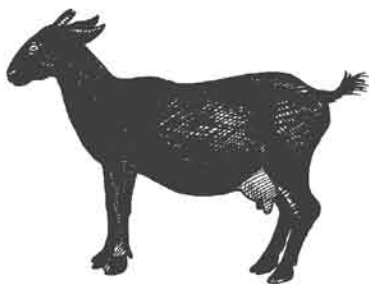

Figure : Black Bengal breed Goat Figure : Jamunapari or Ramchagal breed Goat

Shahiwal and red Sindhi cows also give daily 6-10 litres of milk. The black goat that is raised everywhere in Bangladesh is called Black Bengal Goat. It is famous for meat production. Moreover, the goat of long leg and falling ears that our countrymen rear for milk is called Jamunapari or Ramchagal.

The domestic animal grows with man's affection and care from its birth. So there is a close relation developed between man and domestic animals. Though the domestic animals have different traits, the common characteristics of the domestic animals are given below-

1. The domestic animal becomes domesticated easily.
2. They can get adjusted with the environment of the house.
3. They know their keeper easily.
4. They like the company of man.
5. They respond to the behaviour of man in the house.
6. The domestic animals give birth to their baby.
7. They are mammals.

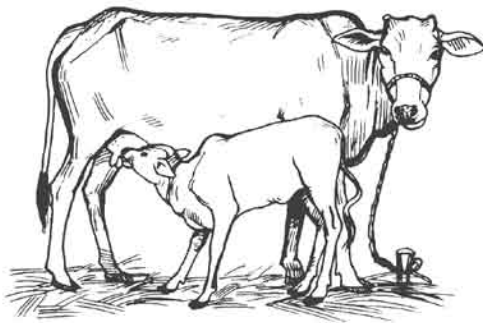

Figure : A mammal's calf



Figure : A divided hoof of a cow



Figure : An undivided hoof of a horse

Cows, buffaloes, goats, sheep are ruminating animals among the domestic animals. Their hooves are divided and they have horns in the head. They graze in the field and eat grass. A horse is not a ruminating animal. They have no horns and their hooves are not divided. They sleep standing. They can run speedily.

Task: Write down the characteristics of a cow or a goat.

New Words : Domestic, rumination.

Lesson-14 : Introduction and characteristics of domestic birds

Ducks, hens, pigeons, etc. are called domestic birds like domestic animals because they can be reared at home with domestication. They lay eggs and give birth by hatching. Children as well as elders show interest in rearing hens, pigeons and ducks. The village people are rearing about 246 million local hens and 46 million ducks. Our local hens lay 45 eggs and our local ducks lay 70 eggs on an average every year. But hybrid Leghorn, Faomi, RIR hens lay 200-250 eggs every year. Foreign breed Indian Runner, Khaki Cambel and Gending ducks lay 250 eggs on an average every year. Peking Duck is famous for meat.



Figure : Khaki Cambel Duck



Figure : White leg Horn

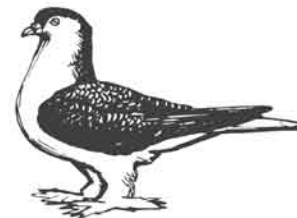

Figure : Lahori pigeon

Domestic birds remain open in a house and they live in special cages built for them. They move around the house all day long after they are released from their cages. but pigeon goes away a long distant in search of food and return home before evening. The common characteristics of the domestic birds are as follows:

1. They become tamed easily.
2. They get adjusted with the environment of houses.
3. They know their keeper and follow for food.
4. They lay eggs in the house and give birth by hatching.
5. They are adept in rearing their babies.
6. They can collect their own food by themselves.



Figure : A hen is rearing its chicks



Figure : A hen is collecting food

They have four fingers in their leg. They have red tuft on their head and they have red flower in their throat. A hen starts to lay eggs at the age of 5 months. A hen tries to save its chickens from wild animals and birds.

A duck is called an aquatic bird. The fingers of the legs of a duck are connected with skin. So they can easily swim in the water. A duck is not that much habituated to hatch eggs. So the eggs of a duck are kept for incubation under a hen.

Task: List the common characteristics of hens and ducks.

New Words : Tuft, aquatic bird.

Lesson-15: The economic importance of livestock

We can be economically benefited by raising livestock. The meat and eggs of the most of the livestock are very popular to men. It is essential to eat meat and eggs and drink milk daily with other foods for the physical and mental development of men. The milk of the cow is a balanced diet. Eggs of hens and ducks are also a very nutritious food. These foods meet up the deficiency of protein in our body. So milk and egg should be in our everyday meal. Meat, eggs, milk, sweet, curd etc. are used in entertaining guests.

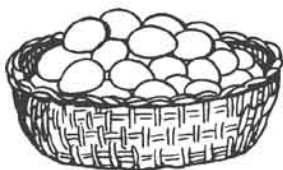

Figure : Eggs of hens and ducks



Figure : Beef

The production of milk, meat and eggs is much less than demand in Bangladesh. The demand and the price of both livestock and their products are high. So we need to set up family farms for livestock. This will meet the demand of nutrition in a family. The additional eggs and milk can be sold into the market to earn money.



Figure: Milk

Cows and buffaloes have been used in cultivation, transportation, threshing, pulling of the hand oil-mill, and weeding the crops. Livestocks keep our ecological balance. Weeds of the field, by-products of crops, kitchen garbage are used as their food. Hens and ducks eat insects and drop-out grains and thus help to maintain ecological balance. The wool of the sheep is used to weave winter garment.

Dogs are faithful pet animals and so they are used for safety in the defence sector everywhere in the world. The security forces use horses to control riots. Many animals including camels, horses, and asses are used in carrying load.

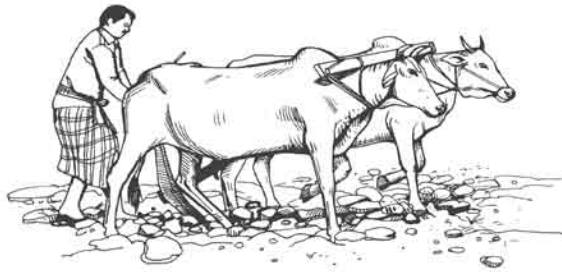

Figure : land ploughing by bullocks



Figure: Horses in transportation



Figure : Threshing crops by cows

Cow-dung and faeces of ducks and hens are used as compost in the field. Moreover, these are used as fodders for fishes and as fuel.

Task: Discuss the benefits of livestock for us in groups and present them in the classroom.

New Words: Balanced food, family farm, hand oil-mill, by-product.

Lesson-16 : Introduction of pigeons and their rearing methods

A pigeon is a very familiar domestic bird to us. Many people in the villages, even in the towns are found to rear pigeons. We usually eat eggs and meat of the domestic birds. But the eggs of the pigeon are not eaten, only the meat is eaten, specially the meat of 3-4 weeks aged baby pigeons. The meat of the pigeon is very soft.

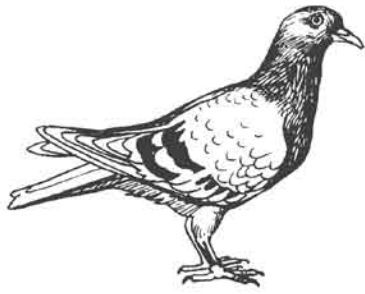
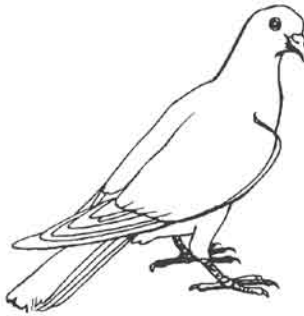
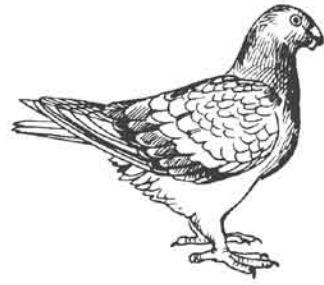
**Figure:** Jalali pigeon**Figure:** White king pigeon**Figure:** Homer breed pigeon

There are different breeds of pigeons in the world. White King, Silver King, Carnow and Homer are world famous for meat. Lahori, Fantail, Siraji, Giribaj, Peacock, etc. breeds are for entertainment. Among the local breeds, there are Jalali, Gola, Goli, Dowka, Loton, Mukki, etc. are seen.

Commercial pigeons are not seen that much in Bangladesh. Many people of the countryside rear pigeons for recreation and hobby. It helps fulfil their family needs of meat as well as recreation.

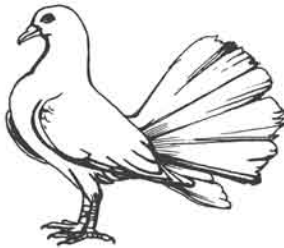
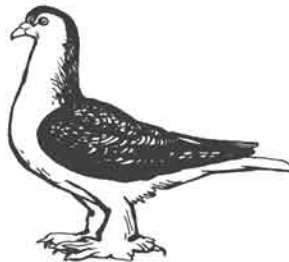
**Figure:** Fantail breed pigeon**Figure:** Lahori breed pigeon**Figure:** Tumbler breed pigeon

A male and a female pigeon live in a pair. At the age of 5-6 months, a female pigeon lays 2 eggs in 48 hours every 28 days. At the time of laying eggs, both of them gather straw in their nest. After laying eggs, both of them gradually brood eggs. Pigeon eggs take 18 days to hatch.

To rear a pigeon is very amusing. The meat of a pigeon is very delicious and nutritious. A pigeon can provide 7-8 pairs of babies within a year. The baby of a pigeon or a dove becomes fit for being eaten within 3-4 weeks. The cost of rearing a pigeon is less. A pigeon can be reared with a small capital. Their diseases are rare.

Task: Make a list of different breeds of pigeons.

Man has been raising pigeons with open methods for a long time. But now-a-days many people are raising pigeons with half-closed methods and closed methods. Pigeons are usually reared with open methods in our country. Again many are found to raise pigeons with wire nets or in a big closed room.

Open method rearing : A pigeon is released in the morning from the nest. They fly around in search of food by day in different places. They sometimes return home to take rest and then go out again. However, they return home before dusk. In this situation, a pigeon is not usually provided any food. But a pigeon does not always get sufficient food from the field. So if a pigeon is regularly provided with some food at home, good babies are got.

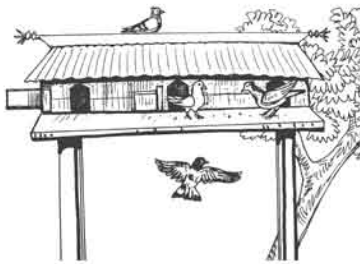

Figure: A pigeon nest in open method

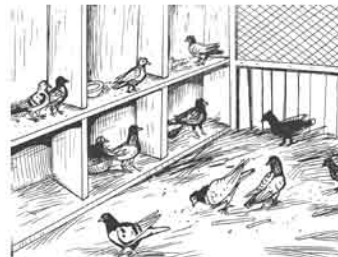

Figure: A pigeon cell in a room in closed method

Closed method rearing : A pigeon is reared within a big room in closed method. So it is necessary to ensure that sufficient light and air may enter into the room. In this method a nest or a cell is made in the room. Moreover, a pot with food and water is managed in the room. It is also noticed that no rain-water may enter the room. The cell is made in such a way that the pigeon may fly in the room. However whatever the method is , a pigeon must not be disturbed when it collects straw, lays eggs and hatches the eggs.

Half-closed method rearing: Expense is less in building a multi-layered nest to rear pigeons in this method. Pigeons are given half of the food at home by calculating. The rest of the food they collect themselves as is done in the open method.

New words : open method, closed method, half-closed method, multilayered, packing wood.

Lesson-17 : Habitat and food management of a pigeon

Habitat of a pigeon: A pigeon likes to live in a single nest or in a cell. The nest of a pigeon is built high from the surface. Their nests are built in such a way that wild animals and birds cannot harm them. The nest or cell is built with wood, slender tin, bamboo or packing wood. If more kids are expected, two nests are set up side by side for a pair. Because while nursing the kids, the pigeon may lay newer eggs and start to hatch eggs in the adjacent nest. The nest may be two or more layered. Expense is less in building a multi-layered nest.

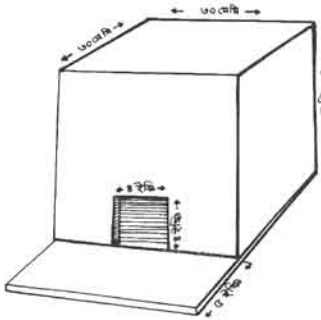

Figure: A single cell for a pigeon

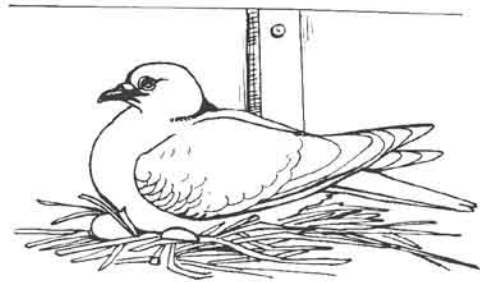

Figure: A pigeon is brooding eggs

Both male and female pigeons feed their squabs simultaneously. They feed their squabs soft food mixed with their bladder liquor keeping their beaks in the beaks of their squabs with affection. The squabs grow up quickly as the liquor mixed soft food is very nutritious. The feather of their wings comes out after 28 days. Squabs can eat using their beaks.

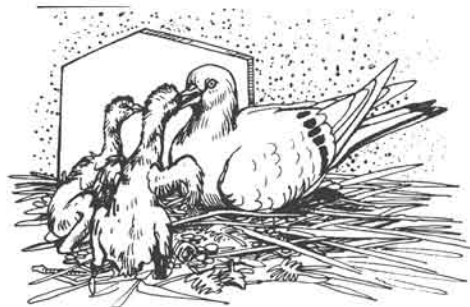

Figure: A pigeon is feeding its squabs

Food of an aged pigeon : A pigeon likes to eat grains such as paddy, wheat, pea, pigeon-pea, mustard, beans, etc. A pigeon can also be fed the balanced food prepared for hens. Every pigeon eats 50 gm of food daily on an average. A pigeon is fed a mixture food of cockle-dust, limestone, wood coal dust, salt, etc. As a result, their mineral deficiency is met up. The food and water for a pigeon is served in a pot. A pigeon itself goes out in search of food in open and half-closed methods. They eat food from different crop fields. However, a pigeon is served prepared food when it is kept at home.

Water supply : 2-3 bowls are to be arranged in the centre of the room for drinking and bathing of a pigeon. The bowl needs to be filled three-fourths with water. The pigeons will drink water and bathe here.

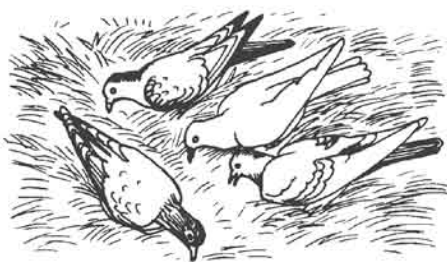

Figure: A pigeon is eating in a field



Figure: A pigeon is eating food provided in the room

A food chart for a pigeon	Food ingredients for a pigeon Percentage (%)
Wheat	30.0
Maize	20.0
Mustard grain	15.0
Pigeon-pea	20.0
Black gram	14.5
salt	0.5
Total	100

Task : Write down the food ingredients for a pigeon and make a food chart for a pigeon.

New Words : Bladder, grain, limestone.

Exercise

Fill in the blanks

1. Paddy, lentil, jute, mustard, sugar-cane are.....crops.
2. More profit in less land is the main economic characteristic of crops.
3. After rotenon is applied to the water of a pond it cannot be useddays.
4. Both male and female pigeons feed their simultaneously.

Match the left column with the right column

Left Column	Right Column
1. Pepper	protein.
2. Jute, cotton	wool.
3. Pulse crop	spice.
4. Red amaranth	thread, cloth.
5. Sheep	short duration crop.

Short answer questions

1. Which fish is called carnivorous?
2. Which domestic bird is called aquatic?
3. When does a pigeon egg become unfolded?

Descriptive questions

1. Write down why lime is used in a pond for fish cultivation.
2. Write two economic importance of domestic animals.
3. Explain the statement-“A pigeon can be reared with a small amount of capital.”

Multiple-choice questions

1. Which one is a fresh water fish?

- a. Churi fish
- b. Shol fish
- c. Hilsa
- d. Vetki

2. If the clay at the bottom layer of the pond dries up –

- i. harmful gas is removed.
- ii. germs are removed.
- iii. natural food is increased.

Which one is correct?

- a. i and ii
- b. i and iii
- c. ii and iii
- d. i, ii and iii

3. Which duck is famous for meat?

- a. Peking
- b. Indian Runner
- c. Khaki Cambel
- d. Ginding

4. Fodder crop is –

- i. wheat, maize.
- ii. felon, gini.
- iii. felon, napier.

Which one is correct?

- a. i and ii
- b. i and iii
- c. ii and iii
- d. i, ii and iii

Read the following passage and answer question no 5 and 6

Aleya Begum cultivated pepper in 5 decimel land beside her house. The seedlings increased properly. When she was collecting crops, there was an attack of aphids and she instantly sprayed insecticide.

5. How much cow dung did Aleya Begum's land need?

- a. 120 kg
- b. 160 kg
- c. 200 kg
- d. 240 kg

6. What kind of effects will have on the crop due to immediate spraying of insecticides?

- a. photo-synthesis will be hampered
- b. the quality of the crop will be increased
- c. crop harvesting will be delayed
- d. transpiration will be hampered

Creative Questions

1. Rowsan Ara decided to cultivate vegetables in the vacant land adjacent to her house, and prepared a plot of 3 decimel for tomato cultivation. She had a bumper yield of tomato for improved variety, use of fertilizer in right dose and proper care and nursing. She met her family needs and sold a portion in the market. Being inspired by the initiative of Rowsan Ara, many in the neighbourhood started kitchen garden in their houses.

- a. What is horticultural crop?
- b. Explain why sand and ash are mixed up with the seeds of red amaranth to sow seed.
- c. Determine how much cow-dung Rowsan Ara used in her land of 3 decimel for tomato cultivation.
- d. Analyse the impact of Rowsan Ara's initiative in meeting family nutrition demand.

2. Monoara Begum is to face difficulty to maintain her family. She has a fallow water body and a piece of open high land in her homestead. She has decided to cultivate pungas in the fallow water body on the advice of her neighbour. Next time she has also planned to use the high land for cultivation.

- a. What is cultivable fish?
- b. Explain one of the economic importance of fish cultivation.
- c. Explain why Monoara Begum chose to cultivate pungas.
- d. Analyse how Monoara Begum's future plan will help to increase her family income.

Chapter Six

Afforestation

A forest is, an area covered with creepers, shrubs and both small and big trees. A special characteristic of a forest is to have tall and woody trees. Different kinds of animals, birds and insect pest living in the forest make a forest environment. Forests make our environment habitable. To have 25% of natural forest land in a country is an ideal condition. According to the government record Bangladesh has 17% of natural forest land. Now it is the demand of time to protect the forest and to create new forests. We will know about natural forest, social forest and agricultural forest and about their nurture in this chapter. Besides we will be able to know the information and realize the importance of forest.



Figure: Sundarbans



Figure: Agricultural forest

At the end of this chapter, we will be able to:

- compare agricultural and social forests with natural forests.
- mark natural forests in the map of Bangladesh and make a list of trees and animals found in those forests.
- establish relationship between agricultural and social forests.
- explain the importance of agricultural and social afforestation in maintaining ecological balance.
- describe how to plant trees and nurture in homestead, roof, tub and school-yard.
- plant trees and nurture in homestead, roof, tub and school-yard.
- draw a poster about the agricultural and social afforestation in maintaining ecological balance.
- realize the contribution of agricultural and social afforestation in maintaining ecological balance.

Lesson-1: Natural, agricultural and social forests

A large area covered with trees is called a forest. The number of large trees is more in a forest. Moreover, medium trees, creepers and shrubs grow in a forest. Different kinds of animals, birds and insect pests live in a forest. These trees and animals live together and create a forest environment.

Classifications of forests:

Forests are of three types on the basis of origin such as –

- a. Natural forest;
- b. Social forest and
- c. Agricultural forest

Natural forest

A natural forest is a widespread area created automatically in nature. This forest is created in hundreds of years. The Sundarbans is such a natural forest. It is situated to the south Khulna town. Shal forests in Gazipur in greater Dhaka and in Madhupur are also natural forests. There are also natural forests in Chittagong, Chittagong Hill Tracts, Dhaka, Tangail, Dinajpur, Sylhet and different areas in our country. The remarkable trees in these forests are sundari, shal, gorzon, geoa, keora, bain, etc. Elephants, tigers, deer, monkey, bears, pythons and various birds and insect pest live in different areas of these forests. Valuable wood is available in these forests. Natural forests play a vital role in maintaining ecological balance. Natural forests are of three types according to expansion in our country; such as - hilly forest, plain land forest and coastal forest.

Task :

1. Why is the Sundarbans called a natural forest?
2. Where is the Shal forest located?
3. Write down the names of five trees and animals of a natural forest.
4. What benefits does a natural forest serve?

Social forest

We plant different kinds of trees in our houses, in schools, on the pond banks, on streets and by the two sides of embankment. Most of these trees are fruit trees. Again forest trees such as rain trees, mahogany trees and koro trees are

also planted. These trees create a shadowy, tranquil and green environment around us. This forest saves us from natural calamities and enriches our economy. A forest which man plans to create for his necessity is called a social forest. Man-made coastal forests are created in the coastal areas of Patuakhali, Noakhali, Bhola and Chittagong. The main trees of this forest are screw pine (Kewra) and banyan tree. Man plans to create different parks and botanical gardens for entertainment and education. These also belong to social forest.

Agricultural forest

Vegetables are cultivated along with big trees in many houses and yards in our country. Small and big trees can be planted in the orchard, in boundaries of crop fields, on the way to the field, around the pond and by canals and irrigation drains. The tree that does not harm field and garden crops should be selected. The forest which is created in such way is called an agricultural forest.

So to say, an agricultural forest is the production system of growing diversified crops, trees, fish and animals and birds in the same land. Field crops, palm tree, nut tree, coconut tree, banana sucker, mango tree, jack-fruit tree, ipil-ipil tree, etc. are planted in an agricultural forest. An agricultural forest plays a role to produce more food. It creates self employment opportunities and side by side preserves the environment.

Task : Discuss in group and fill out the table below.			
	Natural forest	Social forest	Agricultural forest
How created			
Names of trees			
Names of animals			
Benefits			

New words : Natural forest, social forest, agricultural forest, self-employment, environment preservation.

Lesson-2 : Concept and importance of different natural forests

Observe the location of Bangladesh forests in the map with due attention. Identify hilly forests, Shal forests in Gazipur and Madhupur and coastal forest, the Sundarbans observing with your friend. Discuss why these forests are called natural forests. Say something if you see these forests either in reality or on television.

Natural forests are of three types according to expansion in our country such as hilly forest, plain land forest and coastal forest.

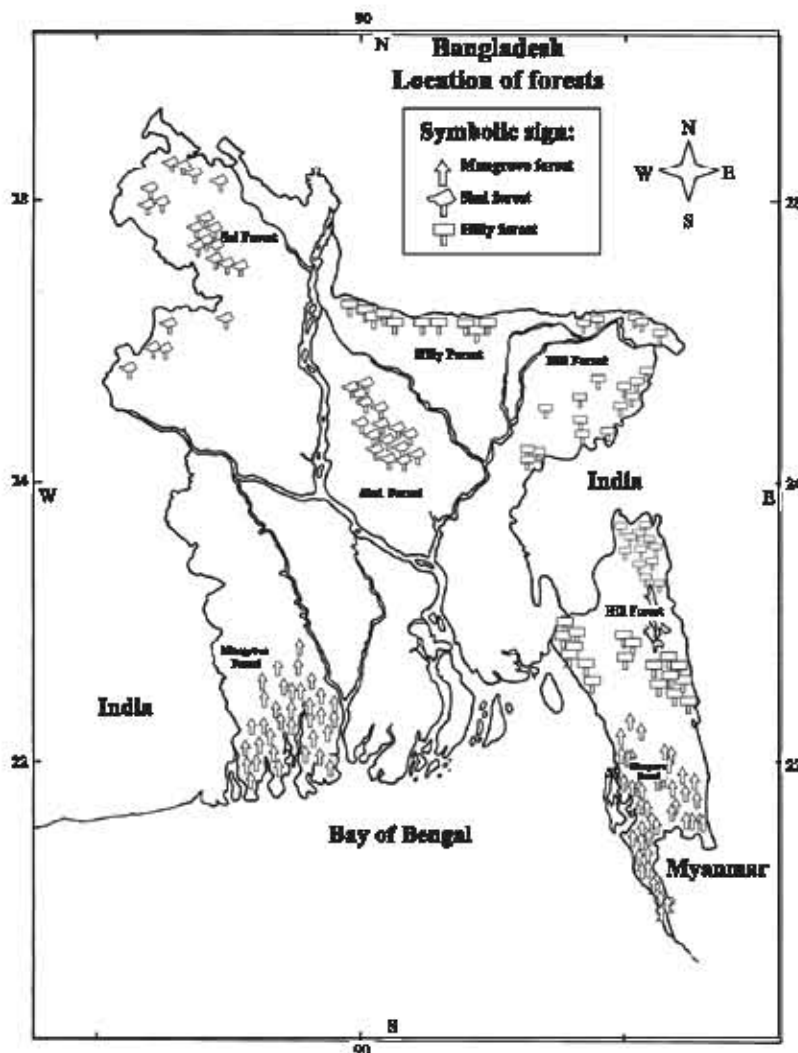

Figure: Location of Bangladesh forests in map

Hilly forest

Hilly forest is the largest among the forest areas in Bangladesh. This forest is situated to the east and to the south-east of Bangladesh. The Natural forests of Sylhet, Moulovibazar, Hobiganj, Chittagong, Rangamati, khagrachari, Bandarban and Cox's Bazar districts are known as hilly forest. Garjan tree, chapalis, telsur, silkaroi, gamar, etc. grow in these hilly forests. We get high quality wood from these valuable trees. Different types of bamboos also grow in the hilly forests. Many wild animals such as 'elephants, monkeys, boars, bears, wild hens, hanumana (entellus), python, etc. live in this forest. A wide variety of birds and insects are also available here.

Plain land forest

The natural forests located in Dhaka, Mymensing, Dinajpur, Rajshahi and Comilla are known as plain land forest. Shal is the chief tree. So this forest is called Shal forest. Shal tree is known as gajari.

Trees like gajari, koroi, rain tree, jarul, etc. also grow in this forest. Animals and birds such as wolves, monkeys, snakes, doves, doels, shaliks etc. live in this forest. The plain land natural forest is decreasing day by day for man-made reasons. The active participation of the local people is necessary for saving the forest from extinction. So social forestation programmes have been started.

Coastal forest

The forest grown naturally in the coastal areas is called coastal forest. Moreover, the forest grown in a planned way in the coastal areas is also called coastal forest. Coastal forest is situated in Cox's Bazar, Chittagong, Noakhali, Khulna, Bagerhat and Satkhira. The coastal forest located in Khulna, Bagerhat and Satkhira is known as the Sundarban. As the forest is frequently submerged with tidal water, it is also known as mangrove forest. The Sundarbans is the largest mangrove forest in the world. The total area of the forest is 6 thousand square kilometre. This forest is the largest coastal natural forest. The natural beauty of this forest is excellent.

Sundari is the main tree of this forest. Moreover, posur, gaoa, goran, kaora, golpata etc. are the remarkable trees of this forest. The main attraction of the forest is Royal Bengal Tiger, spotted deer, leopard, wild boar, monkeys, crocodile, gavials, python and birds and insects of different species live in this forest. Wood collected from trees of this forest are used in building homes, in making newsprint and as fuel. Every year a lot of honey and beewax is collected from this forest.

Task : Complete the figure and make a poster in groups and then present it in the class.

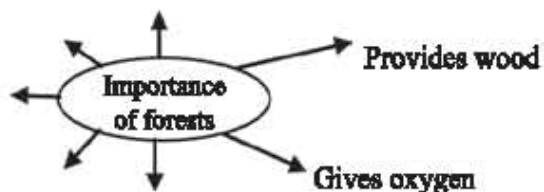

New words : Shal forest, coastal forest, mangrove, natural beauty, hilly forest.

Lesson- 3: Social Forest and Afforestation

Observe the forest in the map. Say some characteristics of social forest. What is called the garden surrounding the school? A forest which man plans to create for his need is called a social afforestation. Forests on roads and embankments and coastal man-made kaora forest are the examples of social forests. Rain tree, koroi, akasmoni, mahogoni are planted on roads and by the two sides of the embankments.



Figure: Forests on roads and embankments (social forest)

Task : Fill in the following chart discussing in groups.		
Different types of social forests name	What kinds of trees are available	What are benefits
Forests in houses		
Forests in school		
Forests on roads and embankments		
Coastal man-made forests		

Social afforestation is undertaken for the increase of forest resources through out the country and to create opportunities of active participation of the rural people in environmental preservation.

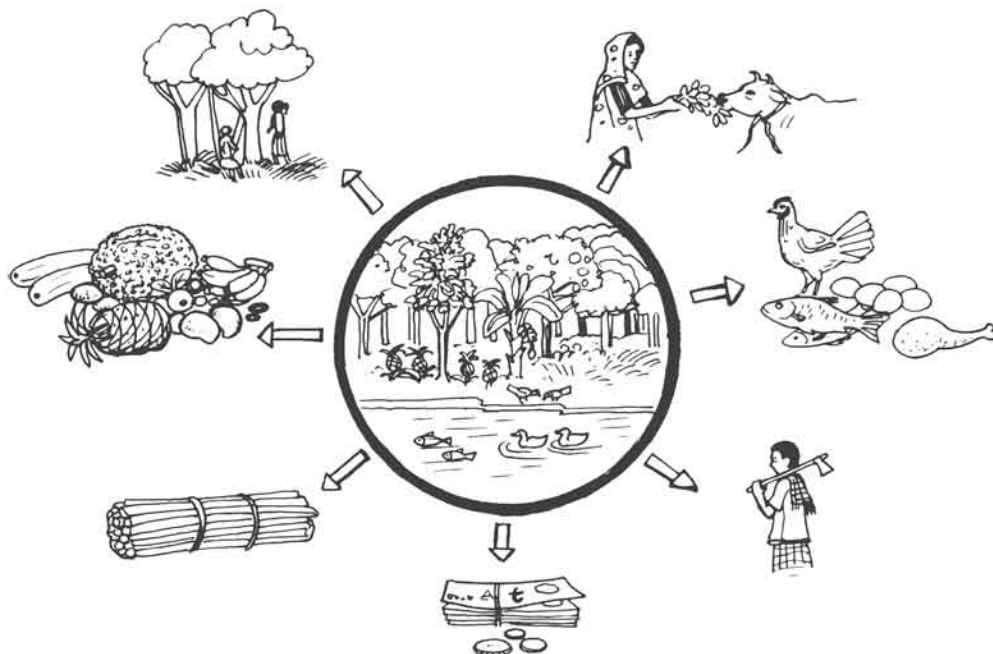

Figure: Importance of social forest

Task : Observe the figure and make a list about the importance of social forest in groups.

Let us match what we have said about the importance of social forest with the following.

Importance of social forest

- A pleasant environment of shade and coolness is created.
- Supply food and nutrition of the rural people.
- Provide wood, fuel and raw materials of industries.
- Employment opportunities of the rural peoples are created.
- Proper utilization of the fallow land is ensured.
- Bring economic prosperity including poverty eradication.

New words : Man-made forest, raw materials of industries

Lesson-4 : Agricultural Forest and Afforestation

Observe the figure of agricultural forest. Discuss in groups and write the characteristics of the figure.

Agricultural afforestation means to produce different trees, crops and animals and birds in the same piece of land at the same time or step by step. The number of trees suitable for agricultural forest is many. Fruit and wood producing trees like betel nut, palm, date babra, coconut, mahogany etc. are planted on the border or in the middle of crop land.

Method of Agricultural afforestation

The density of population is high in our country. The quantity of cultivable land is very limited in comparison with population. So it is the demand of time to grow diversified-crops in the same land. Various types of agricultural afforestation can be followed depending on soil type and local demand. For example-

1. Trees and field crops cultivation method

In this method of agricultural afforestation, integrated cultivation is applied for the cultivation of field crops along with trees in the same field. As a result, the fertility of the land increased and the production is more.

2. Trees and fodder crops cultivation method

In this method, fodder crops are cultivated with trees in the same land. As a result, at one side the fertility of the land is increased and on the other side the production is increased and the erosion of the soil is checked.

3. Forest and fruit tree cultivation method

In this kind of method of afforestation, forest trees are planted with fruit trees. This process is scientific. In this method, diversified production in the land is ensured. Moreover, the fertility of the land is also increased. The habitats of animals and birds and insects are created and the environment is preserved. For example:



Figure: Fruit tree and field crops
(Agricultural forest)

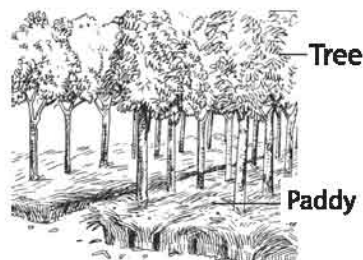

Figure: Trees and field
crop cultivation method

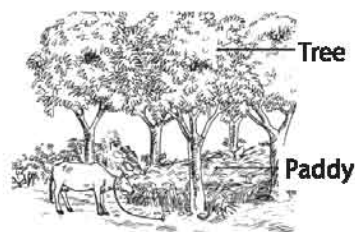

Figure: Trees and Fodder
crop cultivation method

Ipil-Ipil tree, coconut tree, litchi tree planted along with pine-apple.

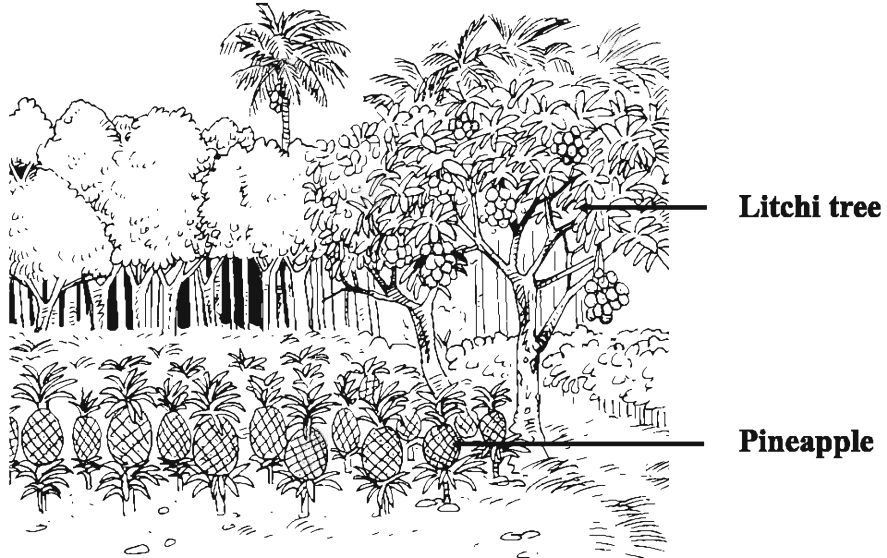
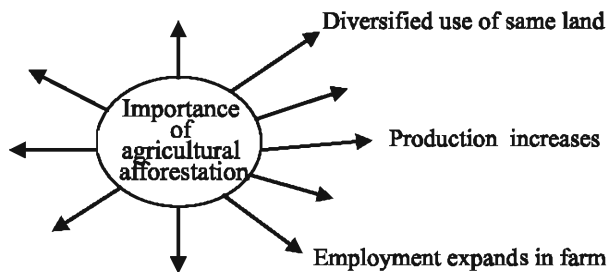

Figure: Forest and fruit trees cultivation method

Task :

Complete the incomplete chart by group discussion.



New words : Agricultural afforestation, integrated cultivation.

Lesson-5 : Difference between agricultural and social afforestation

Agricultural afforestation is the integrated cultivation method of agricultural crops and forest trees. A farmer can make proper utilization of land in this kind of afforestation. As a result, the production increases. The farmer is financially benefitted. Rural people participate directly in social afforestation. Afforestation is performed in different places such as home yards, institutions, roads and embankments, banks of rivers and canals. This afforestation created by people for welfare is known as social afforestation.

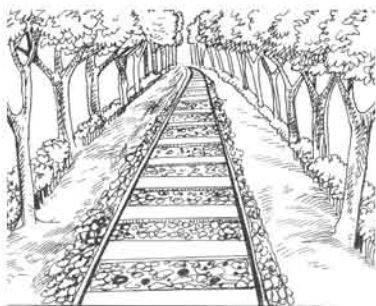
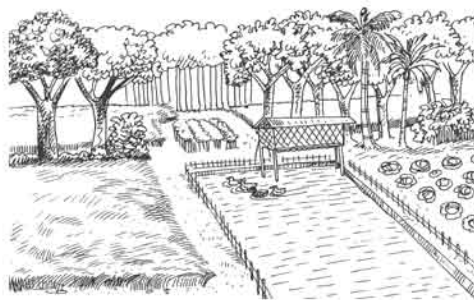
**Figure no : 01****Figure no : 02****Task :**

- Observe the picture 1 and 2. Write which picture is what.
- In which afforestation is the land used more?
- In which afforestation do diversified-crops grow repeatedly in the same land?
- In which afforestation do people participate directly?
- What is called afforestation in institutions, embankments, roads, and railroads?
- Write some names of trees and animals of agricultural afforestation.
- Write down the names of two Plants and animals of social afforestation.
- What sort of afforestation is done in coastal areas and hilly fallow land?

Inter relation between agricultural afforestation and social afforestation:



Figure : Agricultural afforestation



Figure : Social afforestation

1. Crops, trees, feed for fish and animals-birds are produced by agricultural afforestation. The simultaneous production of trees and crops is called agricultural afforestation. But only wood and fruit producing trees can be produced by social afforestation.
2. Social afforestation creates a tree and animal friendly environment. Rural people create social afforestation by direct participation. Agricultural afforestation is created with the efforts of people. In agricultural afforestation, crops are planted with wood and fruit producing trees.
3. In agricultural afforestation, crops are produced gradually using the same field again and again. As a result, more crops are obtained. The productivity of the land increases. The scope of using the same field again and again is less in social afforestation.
4. Agro farms, fish farms, apiculture, sericulture are done in agricultural afforestation. As a result, the supply of daily necessities including food, cloth increases. On the other hand, we get valuable wood and fruits from social afforestation.
5. Social afforestation is done on roads, highways, embankments and railways. Social afforestation is also done at the premises of institutions and markets. Agricultural afforestation is done in the fields, yards, hilly fallow lands and coastal areas. Now-a-days social afforestation and agricultural afforestation are done in the extinct natural forests. For example: Shal forest of Madhupur and Bhawal.

Task: Discuss agricultural afforestation and social afforestation in groups and fill out the following table:		
Questions about differences.	agricultural afforestation	social afforestation
1. Where is this afforestation done?		
2. Write the name of five trees and animals produced here.		
3. Whose participation creates this?		
4. How is the land used?		
5. What are the benefits?		
6. How can you participate?		

New words : A tree and animal friendly environment, an agro farm.

Lesson - 6: Role of forest in maintaining ecological balance

The importance of forests in maintaining ecological balance is unlimited. A country should have 25% of forest land of the total land area which is essential to maintain ecological balance. Now our country has 17% forest land of the total area. Now let us see how these forests contribute to maintaining ecological balance.

1. Trees of the forest absorb carbon-di-oxide of the air and release oxygen in the environment. So the balance of oxygen and carbon dioxide in the atmosphere is maintained.
2. Trees of the forest release vapours in the air. So the environment remains cold. The vapour helps to form clouds and rainfall.
3. Trees of the forest decrease extremity of the weather. They control the speed of the wind blow.
4. Trees of the forest make the soil fertile and make a suitable environment to grow new trees.

5. Trees of the forest produce food for animals and work as their habitat.
6. Trees of the forest save the environment from soil erosion and land slide.
7. Trees of the forest save the localities from natural calamities such as tornado, storm, tidalwave and flood.
8. These forests help preserving bioderersity.

Task :

Make a map about the contribution of agricultural forest and social forest in maintaining ecological balance and draw it on a poster paper.

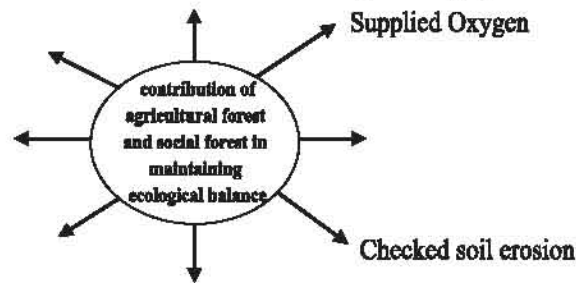

New words: Biodiversity, ecological balance, extremity.

Lesson-7 : Rules of plantation in the homestead areas

Many types of trees are planted around the house. Different types of vegetables are also cultivated in the home yard. As a result, a shadowy and pleasant environment is created in the house. In this environment, the body and the mind remain sound. Fruits and vegetables of the garden meet up the demand of nutrition of people. The extra produced items bring economic solvency in the family.

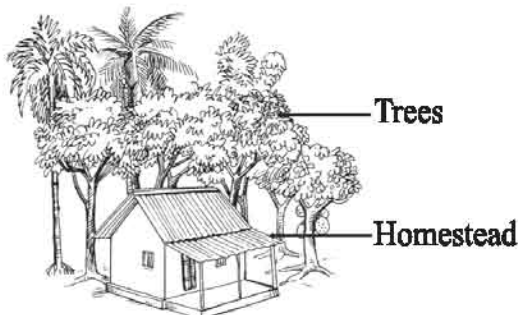

Figure : Trees in a homestead

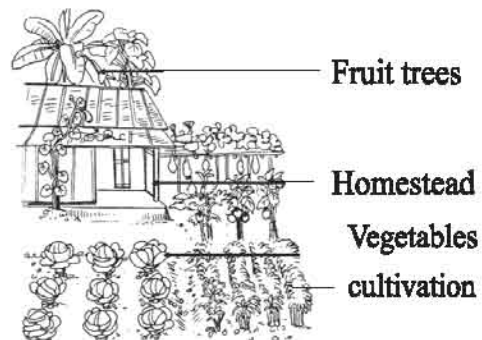

Figure : Vegetable cultivation in a homestead

Fruit trees such as mango, jack-fruit, coconut, betelnut, guava, jujube etc. are primarily planted in houses. Wood trees such as teak, mahogani etc. are seen to be planted in many houses. Moreover, vegetables such as bottle gourd, cucumber, bean, basil, brinjal, tomato, pepper, etc. are cultivated in home yards.

Task : Make a list of the plants at your homestead and discuss if in group and present it.

Things to be taken care of during tree plantation in dwelling houses

1. Trees should be planted a bit away from the home. So that dead branches and dropping leaves cannot harm the thatch and the roof of the residential house.
2. It is to notice that the entrance of light and air is not hampered on the house.
3. Damage to lives and houses can not occur by falling down trees from storm and cyclone.
4. Trees can enhance the beauty of the house and create a pleasant environment.

Rules of plantation at homestead

- Plant small and medium sized plants like custard apple, sugar apple, mehndi, hibiscus etc. on the eastern and southern parts of homestead. It will help movement of sufficient air into the house from the south and the east.
- Strong deciduous trees e.g. betel nut, coconut, redwood, teak etc. should be planted on the west and the south-west. These trees have few branches and they shed leaves in winter. So enough sunlight comes into the house.
- All kinds of trees like mango jack fruit, black-berry, mahogany, rain tree etc. can be planted on the north, north-west and north-east of the house. These big trees protect our houses from northwester.
- Bamboo may be planted on the north-west if there is enough space. Bamboo is used much in rural life. It has economic importance.
- Vegetables may be cultivated on the east and south of the homestead. Creeper like sponge gourd or luffa, yam, country bean, ridge gourd, black pepper, etc. can be grown on the mid-sized plants Ginger, turmeric, giant taro etc. may be grown in the shadowy place.

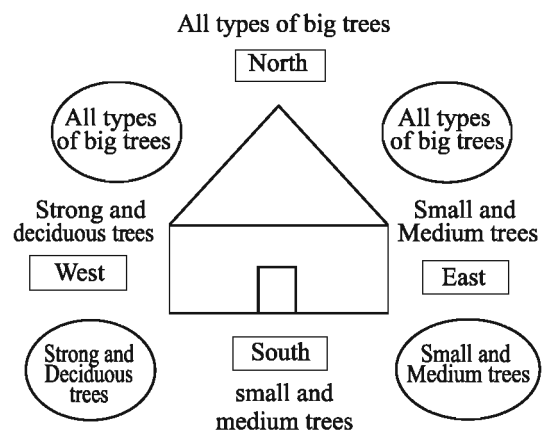

Figure : Diagram of Plantation at homestead

Task :

Discuss in group and write the rules to be followed for plantation at the homestead.

New words : Deciduous trees, nor'wester.

Lesson-8 : Planting trees at the homestead nursing

Rules of planting trees are almost same in everywhere. For tree plantation the homestead needs to be prepared before one month of the starting of seasonal rain. The size of the pit should be (50cm x 50 x cm 50 cm). 10 kg cow-dung manure, 50 gm TSP and 50 gm MOP fertilizers are to be mixed with the soil in the pit. The fertilizers mixed with the soil should be kept in the pit for at least one month. After one month when the seasonal rain will start, seedlings collected from good nursery are to be planted.

Steps in planting seedling in polybag are shown in the figures below

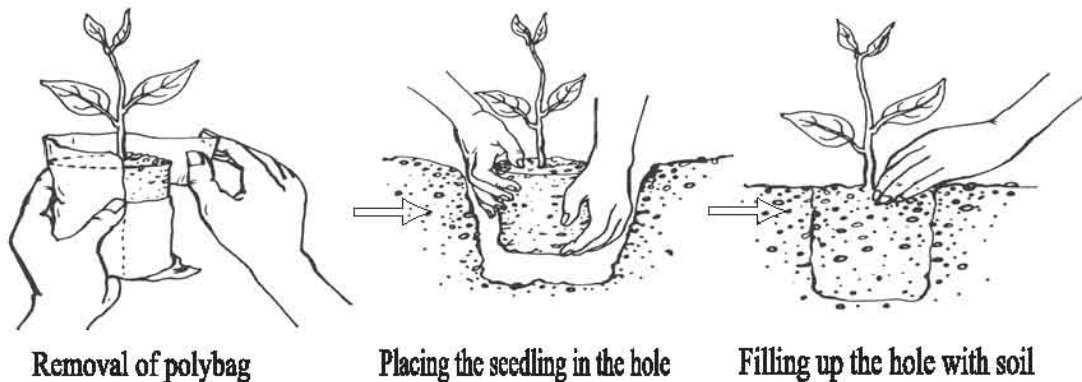

Figure: Different steps in planting seedling in polybag

Necessary precautions in planting seedlings

1. The polybag is to be removed with a sharp blade or knife holding the bag with precautions.
2. It is noticed that the soil in the bottom layer of the seedling does not break down.
3. The surrounding gap should be filled up with soil placing the seedling in the pit as shown in the figure.

4. Care should be taken so that the green portion of the seedling is not covered with soil.
5. The soil at the base of the seedling should be leveled high so that water cannot be stagnant at the base.

Nursing of seedlings

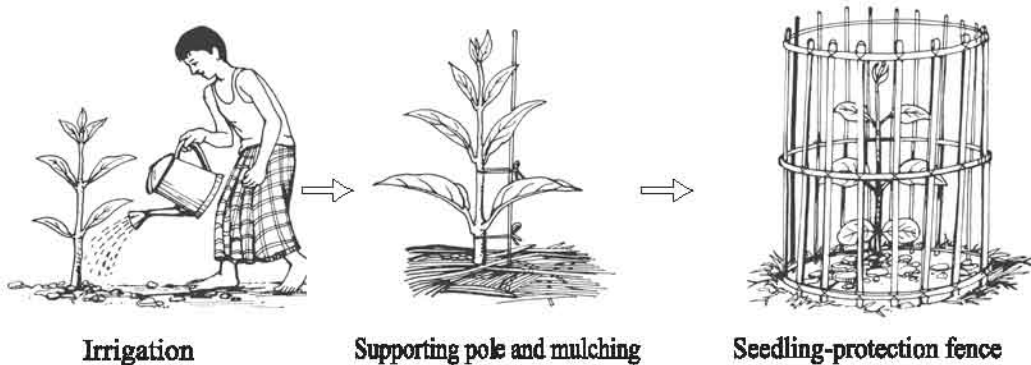

Figure : Different Steps of nursing seedling

The base of the seedling should be weeded out regularly. Arrangements should be taken to keep the moisture of the soil in winter time. So mulching is necessary by scattering straw at the base of the seedling. Regular irrigation should be ensured in the afternoon during dry seasons.

Application of fertilizers

If the growth of the seedling is not good, fertilizer is to be applied after 3-4 months. 50 gm urea fertilizer is to be used for each seedling. 8-10 holes need to be dug with hard sticks 12-15 cm apart from the base of the seedling. 50 gm urea fertilizer is equally divided in these holes. This sort of using fertilizer is called dibbling method. If the soil is dry, it needs to be drenched after the use of fertilizers. Every year fertilizers are used once at the beginning of the rainy season and then at the end of the rainy season. Every time 75 gm of urea, 50 gm of TSP and 50 gm of MOP fertilizers are to be used at the base of the seedling in the dibbling method. It may be necessary to use fertilizers for three years after seedling plantation.

Task : Plant seedlings at the school Premises in groups.

Lesson-9 : Planting on the house roof, in a tub and in school and their nursing.



Figure: A garden in the tub on the house roof



Figure: A garden in school

Tree planting and nursing on the house roof and in the tub

Lemon, orange, guava, bilimbi, carambola, pomegranate, amropoli, mango etc. fruit trees. Almost all flower plants can be planted in a tub on the house roof. Different kinds of vegetables such as bottle gourd, pepper, tomato, basil, brinjal etc. can be cultivated in a tub on the house roof.

Task :

1. Make a list of fruit and wood trees available in your school?

Method of cultivation in tub: Tubs for tree plantation are of different types and sizes. But we need to notice that the size of trees depends on the size of tubs.

Rules of soil preparation for a 45 cm tub

Before planting in a tub, loamy soil and decomposed cow-dung are to be mixed in a proportion of 2:1 ratio. 100 gm TSP and 50 gm MOP fertilizers are to be mixed well and then kept for 15 days. Now the graft or seedling is to be planted in the middle of the tub.

Permanent seed-bed method

Now-a-days it is a modern and developed method for gardening in our country. In



Figure: A permanent seed-bed on the roof

this method, a wall of 50 cm height with 2 metre wide two sides having 15 cm deep net finishing is to be moulded around the roof. 5cm cow-dung is to be put on 5 cm brick-particle placed on the bottom on the gap at the centre.

Now the permanent seed-bed is prepared filling with the mixture of loamy soil and cow-dung in a proportion of 2:1 ratio. Net finishing is a must in every activity of roof moulding and wall building. For this, there is no scope to damage the roof.

Nursing of trees in a tub or on a roof

A moderate liquid is prepared mixing 1 kg decomposed oil-cake with 3 litre water. Half a litre is required for 40 cm tub and 1 litre is necessary for a drum or a permanent seed-bed. This fertilizer is to be mixed regularly at the interval of every 15 days. Water is irrigated before one hour and after one hour of liquid fertilizer application.

Regular irrigation and application of fertilizers are to be ensured for perennial trees planted in a tub. The tub is irrigated in such a way that there is always moisture in the tub. The soil of the tub is to be made loose twice in a week.

Gardens in school : Flower, fruit and wood trees are planted inside and outside of majority educational institutions in our country. Many flower trees such as krishnachura, kathalichapa, sonalu, bougainvillea, jarul, gardenia, china rose, tagor are planted in this garden. Again wood and fruit trees such as mahogoni, rain tree, mango, jack-fruit, coconut, betel nut, etc. are planted.

Winter flower gardens are specially very beautiful in our country. To make these gardens is a must for creating a natural environment in educational institutions and for their beautification.

Task : (Group work)

1: Write down the names of 5 permanent forest trees, fruit trees and permanent flower trees each that can be planted in the school yard.

2: Why should there be a flower garden and a pleasant environment encircled with trees in each and every school? Discuss in groups and write down in point forms in a poster paper. present it in your classroom.

New Words: Permanent seed-bed, perennial tree.

Exercise

Fill in the blank

1. Natural forests in our country are oftypes.
2. andare collected in abundance from coastal forests.
3. trees should be planted on the south and the east of a house.

Match the left column with the right column

Left column	Right column
1. In agricultural afforestation forest trees are	Needed regular irrigation and application of fertillters vegetables may be cultivated in a tub on the roof. planted with fruit trees. is known as social afforestation
2. Pepper, tomato, brinjal etc.	
3. Forestation created by people for the benefit of people	
4. Perennial trees planted in a tub	

Short answer questions

1. What is a coastal forest?
2. Write down 2 importances of social forest.
3. Write down the names of 3 trees that can be planted in a tub on the roof.

Descriptive questions

1. Write down the differences between hilly forest and social forest.
2. Discuss the role of forests in maintaining ecological balance.
3. Describe the method of polythene bag seedling plantation.

Multiple Choice Questions

1. Which one is the main tree of coastal forest?

- | | |
|-----------|----------|
| a. Garan | b. Jarul |
| c. Garjan | d. Gaoya |

2. Which trees are planted to the south and the east sides of the house?

- a. Sugar apple b. Sishu
d. Olive tree d. Teak tree

3. Which one is the group of trees available in social forest?

- a. koroī, akasmoni, gamar b. jarul, rain tree, mahogoni
c. mahogoni, akasmoni, koroī d. koroī, garjan, mahogoni

Read the following passage and answer question number 4 and 5

Salma Begum has planted fruits and flowers of different species in 20 tubs each of which is 45 cm and takes regular care. Her garden is now replete with seasonal fruits and flowers.

4. How much TSP fertilizer is necessary for tubs of Salma Begum?

- a. 1 kg b. 2 kg
c. 3 kg d. 4 kg

5. The initiative of Salma Begum-

- i. helps to preserve ecological balance
ii. meets up the demand of nutrition of the family
iii. increases the family expenditure

Which one is correct?

- a. i and ii b. i and iii
c. ii and iii d. i, ii and iii

Creative questions

1. Rahima Begum has planted trees of different species such as coconut tree, sishu tree, guava tree, black-berry tree in her yard by following the rules of tree plantation. And thus the daily demand of the family is met up and a scope of extra income is created.
 - a. What is a forest?
 - b. Explain an importance of social forest.
 - c. In which direction has Rahima Begum planted the trees mentioned in the passage ? Explain.
 - d. Analyze how Rahima Begum's initiative has brought about prosperity.

- 2.

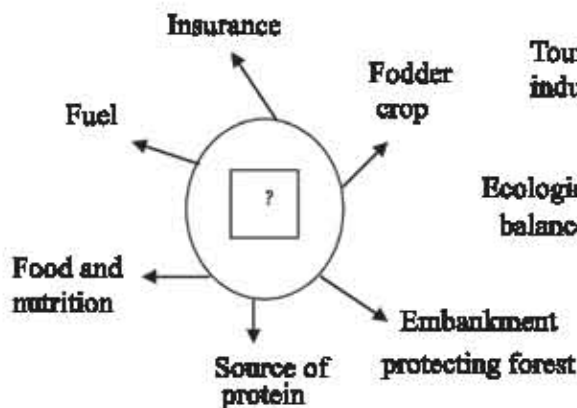
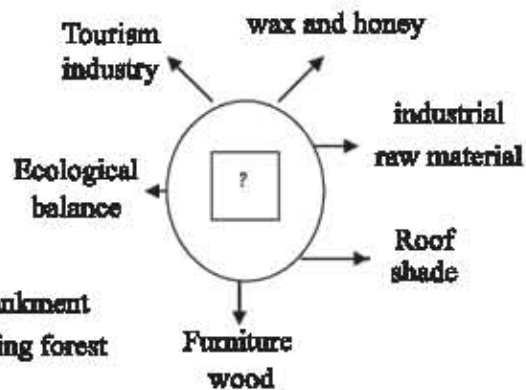
**Figure : A****Figure : B**

- a. What is a hilly forest?
- b. Which forest is called Shal forest? Explain.
- c. Which forest of the above picture is physiographically different? Explain reasons.
- d. Which forest of the above picture is important for social afforestation? Analyse the reasons.

The End

2020

Academic Year

6-Agriculture

বঙ্গবন্ধুর স্বপ্ন— দারিদ্র্য ও নিরক্ষরতামুক্ত সোনার বাংলাদেশ গড়তে
নিজেদের যোগ্য নাগরিক হিসেবে গড়ে তোল

— মাননীয় প্রধানমন্ত্রী শেখ হাসিনা

জীবসেবা পরম ধর্ম

তথ্য, সেবা ও সামাজিক সমস্যা প্রতিকারের জন্য '৩৩৩' কলসেন্টারে ফোন করুন

নারী ও শিশু নির্যাতনের ঘটনা ঘটলে প্রতিকার ও প্রতিরোধের জন্য ন্যাশনাল হেল্পলাইন সেন্টারে
১০৯ নম্বর-এ (টোল ফ্রি, ২৪ ঘণ্টা সার্ভিস) ফোন করুন



Ministry of Education

For free distribution from academic year 2010 by the Government of the
People's Republic of Bangladesh