

Science

Class Six

Investigative
Study



National Curriculum and Textbook Board, Bangladesh



জলবায়ু পরিবর্তনের বিরূপ প্রভাব মোকাবেলায় বিচক্ষণ নেতৃত্বের স্বীকৃতি হিসেবে পাওয়া জাতিসংঘের 'চ্যাম্পিয়ন্স অব দি আর্থ' পুরস্কার গ্রহণ করছেন প্রধানমন্ত্রী শেখ হাসিনা

জাতিসংঘের পরিবেশ বিষয়ক সর্বোচ্চ পুরস্কার 'চ্যাম্পিয়ন্স অব দি আর্থ' পদকে ভূষিত হন মাননীয় প্রধানমন্ত্রী শেখ হাসিনা। পরিবেশ আদালত আইন, পরিবেশ ও জীব-বৈচিত্র্য সংরক্ষণ ও উন্নয়নে সংবিধানে ১৮-ক অনুচ্ছেদ সন্নিবেশ, বন্যপ্রাণী (সংরক্ষণ ও নিরাপত্তা) আইন, ইট প্রস্তুত ও ভাটা স্থাপন (নিয়ন্ত্রণ) আইন, বাংলাদেশ জীব-বৈচিত্র্য আইন প্রণয়ন এবং জলবায়ু পরিবর্তনজনিত তহবিল গঠন এমন বহু গুরুত্বপূর্ণ অবদানের স্বীকৃতি হিসেবে বাংলাদেশের প্রধানমন্ত্রীকে ২০১৫ সালের ২৭শে সেপ্টেম্বর আনুষ্ঠানিকভাবে এই পুরস্কার প্রদান করা হয়।

Developed by the National Curriculum and Textbook Board as a textbook according to the National Curriculum 2022 for Class Six from the academic year 2023

Science | Investigative Study

Class 6 (Experimental Version)

Written by

Dr. Muhammed Zafar Iqbal
Dr. Haseena Khan
Dr. Mohammad Mizanur Rahman Khan
Dr. Mustak Ibn Ayub
Rony Basak

Edited by

Dr. Muhammed Zafar Iqbal

Translated by

AKM Azizul Haque
Ramij Ahmad
Muhammad Ali



National Curriculum and Textbook Board, Bangladesh

Published by
National Curriculum and Textbook Board
69-70, Motijheel Commercial Area, Dhaka-1000

[All rights reserved by National Curriculum and Textbook Board, Bangladesh]

Published: December 2022

Art Direction

Monjur Ahmed
Nasreen Sultana Mitu

Illustration

Sabyasachi Chakma
Moumita Shikder

Cover illustration

Nasreen Sultana Mitu

Graphics Design

Nasreen Sultana Mitu
Mahatab Rashid



For free distribution by the Government of the People's Republic of Bangladesh.

Printed by:

Preface

In this ever-changing world, the concept of livelihood is altering every moment. The advancement of technology, in accordance with knowledge and skill, has accelerated the pace of change. There is no alternative to adapting to this fast changing world. The reason is, the development of technology is at its zenith compared to any time in the human history. In the fourth industrial revolution era, the advancement of artificial intelligence has brought a drastic change in our employment and lifestyles and this will make the relationship among people more and more intimate. Varied employment opportunities will be created in near future which we cannot even predict at this moment. We need to take preparation right now so that we can adapt ourselves to that upcoming future. Although a huge economic development has taken place throughout the world, the problems of climate change, air pollution, migrations and ethnic violence have become much more intense than before. The epidemics like COVID 19 has appeared and obstructed the normal lifestyle and economic growth of the world. Different challenges and opportunities have been added to our daily life. Standing on the verge of these challenges and possibilities, implementation of sustainable and effective solutions is required for the transformation of our large population into a resource. It entails global citizens with knowledge, skill, values, vision, positive attitude, sensitivity, capability to adapt, humanity and patriotism. Amidst all these, Bangladesh has graduated into a developing nation from the underdeveloped periphery and is continuously trying to achieve the desired goals in order to become a developed country by 2041. Education is one of the pivotal instruments to attain the goals and there is no alternative to the modernization of our education system. Developing an effective and updated curriculum has become crucial for this modernization. Developing and revising the curriculum is a regular and vital activity of National Curriculum and Textbook Board. The last revision of the curriculum was done in 2012. Since then, a lot of time has passed. The necessity of curriculum revision and development has emerged. For this purpose, various research and technical exercises were conducted under the supervision of NCTB during the year 2017 to 2019 to analyze the prevalent situation of education and assess the learning needs. Based on the researches and technical exercises, a competency-based incessant curriculum from K-12 has been developed to create a competent generation to survive in the new world situation. In the light of the competency based curriculum, the textbooks have been prepared for all streams (General, Madrasah and Vocational) of learners for grade VI. The authentic experience driven contents of this textbook were developed in such a way that teaching learning becomes comprehensible and full of merriment. This will connect textbooks with various life related phenomenon and events that are constantly taking place around us. We hope that learning will be profound and life-long now. Issues like gender, ethnicity, religion, caste, the disadvantaged and students with special needs have been taken into special consideration while developing the textbook. I would like to thank all who have put their best efforts in writing, editing, illustrating and publishing the textbook. If any one finds any errors or inconsistencies in this experimental version and has any suggestions for improving its quality, we kindly ask them to let us know.

Professor Md. Farhadul Islam

Chairman

National Curriculum and Textbook Board, Bangladesh

Table of Contents

















	Page
 Chapter 1 : Science and Technology	01
 Chapter 2 : Matter and its Properties	14
 Chapter 3 : The Living World	23
 Chapter 4 : Plants, Animals and Microorganisms	32
 Chapter 5 : Weather and Climate	48
 Chapter 6 : Earth and Universe	59
 Chapter 7 : Motion	69
 Chapter 8 : Force and Energy	76

Table of Contents

	Page
 Chapter 9 : Rotation of Sun, Earth and Moon and their Relative Positions	89
 Chapter 10 : Properties of Matter and its External Effects	101
 Chapter 11 : Human Body	111
 Chapter 12 : Mixture and Separation of the Components of Mixture	124
 Chapter 13 : Nutrition and Metabolism of the Organism	139
 Chapter 14 : Light	144
 Chapter 15 : Environment and Topography	154
 Chapter 16 : The interdependence of the organisms and the sustainable environment	165

A few words for the students –

Students, how are you all? Welcome to the Science subject of Class Six! You can see, there is going to be a big change in the way you have been studying for so long! Your books on all subjects are also a little different this time. You must have got two books on Science! Along with this ‘Investigative Study’ book you are given another ‘Work Book’. If you have a look, you will realize that there is a big difference between this book and the work book. Honestly speaking, the way you used to try to learn science by reading different chapters of textbooks, now this way of learning is completely changing. Throughout the year, you will go through several new experiences, solve some new problems. These new experiences and problem solving steps are detailed in your work book. In solving these problems, you will need to know different aspects of science at different stages. This ‘Investigative Study’ book will help you in this regard. At school or at home, wherever you are, you can use this book to solve problems yourself if needed!

This book covers the topics of Science that you will need to know in Class Six. The topics are organized in sixteen chapters. Many of these things will be useful to you at different times in the experiences that you will go through throughout the year.

So let us start, what do you say?



Chapter 1

Science and Technology

Chapter 1

Science and Technology

At the end of this chapter, students will be able to know the following:

- ☑ The concept of science, the concept of technology
- ☑ Science to technology
- ☑ Good technology, bad technology
- ☑ The process of scientific inquiry
- ☑ Measurement of different 'quantities', different types of measurement methods
- ☑ Measurement on small and large scales
- ☑ Perfect measurement, if necessary
- ☑ Scientific inquiry and processing skills
- ☑ Safety and necessary precautions in scientific experiments
- ☑ Different measurement methods

Science

When we hear the word 'Science', we imagine some scientists doing research on various complex problems with different types of modern equipments in big modern laboratories. For that reason, many people think that everyone cannot

understand the practice of science. They think that many opportunities are necessary for the practice of science. They also think that a scientist must be very talented. In fact, that is not true; science is for everyone. Science can be researched without large modern laboratories. Madame Curie twice won the Nobel Prize in Physics and Chemistry, but her laboratory was very simple.

The main point is, science is a kind of knowledge that can always be verified by experiments. But the more important thing is that science is such a way of thinking in which we ask

Scientist
Madame
Curie



questions about everything and verify with explanations. We can ask questions about the theory of the greatest scientist of the world and experiment and verify whether that is true. Different theories of science from thousands of years are regularly being verified. That's why we know to what extent these theories are true. We change or revise the theories of science when necessary. For that reason, we can depend upon science. Science is a type of knowledge which we can verify with discussion, observation and experimentation. But remember that all types of knowledge is not the field of science. The real world around us is the field of science. That is, nature and natural phenomena are the fields of science. But knowledge about subjects like love, envy or morality is beyond the scope of science.

Two Scientists

To understand the subject of science properly, let's now talk about two inventions of two scientists. Everyone in the world knows the name of the first scientist. But when you see the second one, you can't imagine that he is a scientist, only a few people in our country know him.



Sir Isaac Newton

Who doesn't know about Newton? He has many epoch-making inventions in many fields of science. But let's talk about a relatively simple invention here. He said that the ray of the Sun may seem colourless but actually it is made up of many colours. During the time of scientist Newton's works, there was no such thing as experimentation. If a scientist gave a theory, everyone would discuss and try to find out its validity. Scientist Newton not only gave his theory, but also analyzed seven different colours by dividing the sun's ray with a prism. He didn't stop there only, he combined seven

colours with another prism and turned the ray colourless again! Scientists had no option but to accept Newton's theory as a result of unquestionable proof through experiments.

Haripada Kapali



Haripada Kapali is an ordinary farmer in Jashore area. He planted IRRI paddy in his field. One day, he observed that the paddies in some parts of his field are bigger, and their yield is higher. Although Haripada Kapali was a farmer, he had a scientist's mind. So he separated these bigger paddies from the rest. He replanted their seeds. He wanted to see if they were really high yielding seeds. They also became quite large and yielded a lot of paddy.

True scientists are not selfish, they work for everyone. Haripada Kapali also shared his paddy seeds with others. All the farmers in the area started getting high yielding paddy!

When people came to know about this discovery by the scientist Haripada Kapali, various organizations started analyzing it. His paddy was named Hari Dhan. Many institutions of the country honoured him with awards and his scientific discovery was written in the textbook.

You are told about these two scientists so that you understand that science is not just for large laboratories and skilled, efficient scientists. If an ordinary man has a scientific mind, then he too can contribute to science.

Technology

When the knowledge of science is applied to fulfill one of the needs of our life, it is called technology. As we know from science, the mass of matter can be converted into energy. That knowledge is applied to generate electricity in nuclear power plants. This electricity is used in many aspects of our lives. You must know that such a nuclear power plant is being built in our Ruppur. Again, nuclear bombs were made using the same knowledge. In two separate use of atom bombs directly on humans, hundreds

of thousands of people were killed in a matter of moments. So, we can see that a wonderful knowledge of science can be applied as a technology for the betterment of human beings. Likewise, the same science can also be used for the destruction of human beings.

Since science is a process of knowledge and thought, there is no chance of something bad to be present in science. But when a technology is developed applying that very knowledge, the technology may be either good or bad. We have already given you one such example, the nuclear power plant and the nuclear bomb. Similarly the knowledge of biochemistry is applied to make medicines which save human lives. But the same knowledge is used to make terrible drugs which are the source of the biggest crime in the world.



Nuclear energy can be used in both good and bad purposes.

We have said in the beginning that when science is applied to fulfill our needs, it is called technology. If you keep your eyes and ears open, you will see that sometimes these technologies do more harm than benefit. For example, polythene bags- we throw away these bags once we have used them. As they do not decompose, the polythene bags, along with wastes, finally take shelter in riverbed or nature. Thus they cause great disaster first to the country and then to the world. If people used a cloth or gunny bag, this would not be a disaster. Therefore, it can surely be said that the technology of disposable polythene bags is actually an unnecessary technology. Again, there are some wonderful technologies that have brought a huge change in our quality of life. But the same technology can be used by a person for unnecessary, meaningless and even harmful works. A vivid example of this is in front of your eyes, which is the smart phone. You don't have to tell anyone how useful a smart phone is. But sometimes you will see a person to waste his time by using it for no reason at all. Many young people have lost their ability to concentrate, using it unnecessarily. Not only that, sometimes by using social media, they are spreading hatred among the people. That is to say, the welfare-oriented technology can be used for harm too. Therefore, you have to be very careful when using technology. Science can never be bad. But even though technology is made for the well-being and welfare of human beings, it can be good, it can be bad, it can be unnecessary, or it can be misused. Therefore, before using technology, you should always be sure about this.

Scientific Inquiry

Aristotle



Aristotle was the wisest man of his time. The wise men of that time practised art, literature, music, science and everything. So Aristotle had many theories about science too. One theory was about heavy and light objects. Aristotle said that if a heavy and light object were dropped from above, the heavy object would fall down first. At that time, everyone valued the words of wise people. Therefore, everyone's belief for two thousand years is considered to be true.

You might be confused to think about it. If a heavy object falls fast and a light object falls slowly, then what might happen if these two are tied together? In that case, the light object will prevent the heavy object from falling too fast. Again, if two things are tied together then the total weight is more and it should fall faster. So which one is true? What is the answer to this question?

By showing reasons we can come up with an answer that, in fact, all heavy and light objects will fall down together. But we do not see that happening- if we leave a stone and a piece of paper from above, the stone always falls first. We can show a reason to explain that too- we can say that a piece of paper takes more time to fall due to wind obstruction. If you can do the experiment in an airless place, you will see that the two are falling down at the same time. But it is not easy to find a place without air, so we can take a light object of very small size with a heavy object so that there is not much obstruction in the air. It is said that Galileo showed that heavy and light objects fall down together by dropping one such heavy and another light object from the top of the Leaning building of Pisa.

Galileo

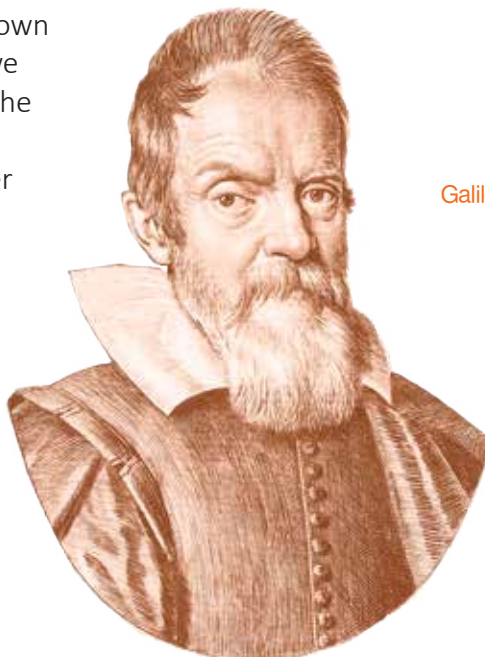

The above example is a beautiful example of scientific inquiry. This is still the method of scientific inquiry. There are six steps in total, the steps are as follows:

1. A question that needs to be answered

(In the example above, the question is - which one of heavy or light object falls first?)

2. Knowing what research about this is already done

(In the example above, this step was Aristotle's explanation.)

3. A possible explanation for the question

(A possible explanation for the above example is that both heavy and light objects will fall down together.)

4. Examining whether the probable explanation is true.

(In the example above, Galileo dropped heavy and light objects from the Leaning tower of Pisa as an experiment.)

5. Making a decision by analyzing the experiment results.

(In the example above, Galileo decided that his idea was correct.)

6. Letting everyone know the idea.

(Galileo shared his idea with everyone, and then others also tried it.)



If you look at the great scientific inventions of history, you will see that they have always searched for an answer to a question. Again, it is also true for the daily happenings around you. You can find the answers to many questions in this way just through scientific inquiry.

The main point is, if the subject is science, then the answer is not to be blindly accepted; rather, to accept after verification is science. Not everyone will be a scientist, but everyone will be science-minded.

Measurement of Different Quantities

If you throw a stone above, it will come down again. People have been experiencing it since ancient times. But this knowledge cannot become a complete science, until you can answer: how much further a stone will fall from you if you throw it at what direction and how much time it will take, how high it will go up and how far it will reach, There is also the condition that how powerfully the stone is thrown and how much is its weight. This means that we have to say everything after measuring in the practice of science.

The things that we can measure are called 'quantities'. So the temperature that rises after you have a fever is a 'quantity'. However, the bad feeling in your body due to fever is not a quantity. In the same way, the mass of a Rasgollais a quantity. But the pleasure of eating Rasgolla is not a quantity. So you must have guessed by now that we have to measure a lot of quantities to practise science. To measure quantities, we need to create exact units, such as meters, centimeters, or kilometers for length; Kg or pounds etc. for mass. But the bigger question is how many quantities are there, how many units will it take for them? If we want to imagine some quantities, we can say in one breath: length, width, height, volume, weight, density, position, velocity, pressure, temperature, electrical conductivity, thermal conductivity, colour, hardness. That is, there is no end of quantity. How many units do we need to explain them?

It is a matter of happiness, there are a great number of quantities in the world around us, but if we can create seven units for just seven quantities to explain them, we would be able to create all the quantities in our familiar world by using them. You use four of these seven quantities every day. They are: length, mass, time and temperature. (The other three are electric current, measurement of matter, luminosity of light, you will also learn about them in the upper class.) The units for measurement are all set internationally. Although different units are used in different countries or regions, the internationally recognized SI units are: Metre (m) for Length, Kilogram (kg) for mass, Second (s) for time, Kelvin (K) for temperature. Let us now discuss a little more about the measurement of these four common units.

Method of Measurement

You must understand that it is very important to measure accurately. If you started walking five kilometers and find that you have to walk five miles, then you have to walk more than one and a half times of your original intention. If your mother asks you to bring five kilograms of rice and you bring five pounds of rice that is less than half the quantity your mother asked for! We can somehow get rid of this kind of mistake in our daily life but in important places this mistake can be fatal. Due to a

measurement error, on 23 July 1983, an Air Canada passenger plane, Boeing 767 discovered in the midway that the fuel is finished. Without the slightest amount of fuel, the skilled pilot was able to bring it down to a nearby abandoned race course. NASA's spacecraft of 125 million worth crashed on Mars on 23 September 1999, due to similar measurement error. So measurement is a very important thing.

Now let us look at four of our familiar units to be useful for the use in science.



The international unit of length is metre, abbreviated 'm'. However, inches and feet are still widely used in everyday life. This book will use 'metre' as a unit of length as measurement of science. We will use the metre as a scientific unit of length in this book. Those of you who have a metre stick in your hand can realize how far one metre means. Roughly speaking, the distance from the feet to the waist of a human being is one metre. However, a standard metre stick for measuring the distance of one metre exactly was previously kept in a museum in France. Nowadays scientists use an interesting method to measure the distance of one metre. The speed of light is very fast; it travels 3 lakh kilometres per second. But scientists used this unthinkable speed of light to cover the distance of one metre. You will learn how to do it when you study in the upper class. Since the speed of light is the same in all parts of the universe, the distance of one metre in any part of the universe, not just anywhere in the world, can be calculated very minutely. If you are asked how far is Sylhet from Dhaka, then you will give the distance in kilometre instead of metre; one kilometer equals to 1000 metres. Similarly, if you are asked about the length of your nails, you will say that length in millimetre, instead of in metre; millimetre is one thousandth of one metre. Besides, Centimetre is also widely used. One centimetre is 1/ 100th of a metre or 10 millimetres. Things smaller than millimetre are usually not measured with the naked eyes.

From the above discussion, you must understand that if you have to say the length of an object, then you have to decide the distance in metre or in kilometre or in centimetre or in millimetre. Honestly speaking, when you read about the planets and stars in space, you will see that we have to use another unit other than these units for convenience!

Mass



The unit of mass is kilogram (kg in short). Once upon a time, the 'real' one kg mass was kept in a museum in France. From May 2019, we do not depend upon the mass preserved in any museum for the 'ideal' or 'real' unit. They can be extracted from some of the constants of science.

We probably use kg most of the time in our daily life. Since we have become accustomed to bottles of water or soft drinks nowadays, we can say that the weight of one litre bottle of water or soft drink is one kg. Or the weight of four standard glasses of water is one kg.

Some of you may be wondering that we use kg to measure weight; we are very used to saying that our weight is 30 kg. Then why are we using the word 'mass' again and again without using the common word 'weight'?

The reason is very important. According to the scientific terminology, there is a huge difference between mass and weight. The unit of mass is kg. Weight has a different unit which you will learn in upper classes. Therefore, your 30 kg weight is scientifically a wrong expression. But in our daily life, we do not bother about it! One mass attracts another mass; since the mass of the earth is much more, so is its attraction. This attraction is actually weight. Since the mass of the moon is less than the mass of the earth, if you go to the moon, you will see that the attraction of the moon is less on you. That means you will feel you weigh less, you will be able to jump much higher than here. So even though your mass is 30 kg in both Earth and Moon, your weight is different in Earth and Moon!

We have already seen that metre as well as inch and foot are widely used as unit of length. Similarly, pound was used beside kg for mass. But nowadays it is comparatively less. We have used centimetre or kilometre to mean more or less distance in terms of length. We do the same in the case with mass. In terms of lesser mass, we use gram (g) which is $1/1000$ th of one kilogram. To measure less than that, we use milligram (mg) which is $1/1000$ th of one gram. You will see on the tablets of medicine that the amount of active ingredient is always given in mg.

Time



Of all the quantities, the time quantity must be the most familiar to us. There is no division in the world with its original unit. Everyone has accepted second (s) as the unit of time. In pure science, a certain number of vibrations of a certain atom is measured as one second. We can take the time required to pronounce the word 'এক হাজার এক' (one thousand one) as one second. Although there are kilometre and kilogram in terms of length and mass, there is no term as kilo second for time! You all know that one minute equals to 60 seconds and one hour equals to 60 minutes. However, even if there is no kilo second, there is millisecond which is $1/1000$ th of second. But this time is too short for us to feel in our daily life.

There are many examples close to 1 second around us. Our heart usually beats 1 time per second, a little more for someone, a little less for someone. We blink once every two seconds; someone takes a little more, someone a little less. We breathe once every five seconds; someone takes a little more, someone a little less!

Temperature



We have all sometimes said 'feeling hot' or 'feeling cold'. We also know that tea is hot and ice cream is cold. The words hot and cold refer to the quantity called 'temperature' which is relatively high or low. So

we can actually understand the temperature with our physical senses, of course if it is within our tolerance.

The international unit of temperature is Kelvin (K), although we never use it in our daily lives. The unit which we use most for temperature in our daily life is Celsius (C). The temperature of water being frozen in this unit is 0°C and the temperature of water evaporating is 100°C . However, the interesting thing is that even in the case of Kelvin unit, the difference between the temperature of water evaporation and freezing is 100K.

Therefore, there is no difference to say that the temperature of something has increased 10°C or 10K. Then naturally you can ask- "What is the difference between these two units?" The difference is 273.15° !

That is, adding 273.15 to the temperature of Celsius scale gives Kelvin scale. It means, on Kelvin scale, the temperature of ice is $0 + 273.15 = 273.15\text{K}$ and the temperature of water evaporation is $100 + 273.15 = 373.15\text{K}$!

Naturally you would then ask what is the reason for creating a Kelvin scale by adding this peculiar number to such a simple scale of Celsius?

The reason, however, is very surprising. There is no limit to how much you can

raise the temperature of anything! But you cannot reduce the temperature as much as you want. There is a minimum value of temperature. Honestly speaking, you can get close to this temperature but never reach that temperature. This is called absolute zero temperature. The Kelvin scale is designed to hold this temperature at zero degree. This temperature on the Celsius scale is -273.15° . So by adding 273.15 to the Celsius scale, we get the Kelvin scale.

However, in addition to the Celsius scale, another temperature scale called Fahrenheit is used in some countries and in fever measuring thermometers. On that scale, the temperature of ice is 32°F and the temperature of boiling water is 212°F . The normal body temperature on the Fahrenheit scale is 98.4°F which is 37°C on Celsius scale.

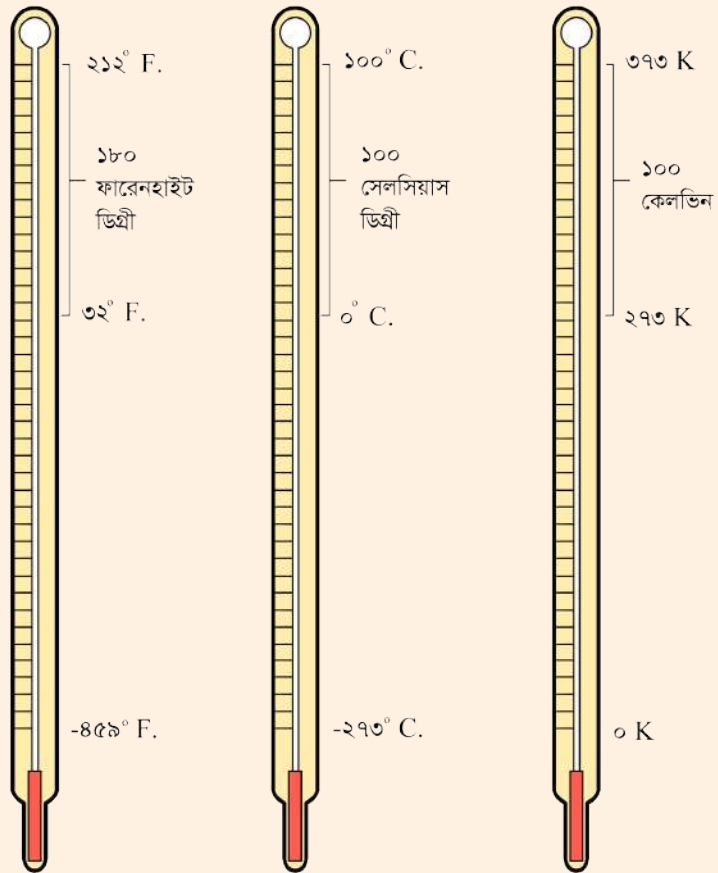

Temperature on Fahrenheit scale

Temperature on Celsius scale

Temperature on Kelvin scale

Fundamental Unit and Derived Unit

We have talked about the units for measuring length, mass, length time and temperature. They are metre, kilogram, second and kelvin. These are the basic units. So if we measure the length of something, then only the basic unit can be expressed in metre. But if we want to measure the area of a room, we cannot express it with the basic unit metre.

If the length of the room is 5 metres and the width is 2 metres, then the area of the room,

$$\text{Area} = \text{Length} \times \text{Width} = 5 \text{ metre} \times 2 \text{ metre} = 10 \text{ square metres}$$

Since the unit is 'square metre', we will call it derived unit. If a car goes 15 metres in 3 seconds, then its velocity is-

$$\text{Velocity} = 15\text{m} / 3\text{s}$$

$$= 5 \text{ m} / \text{s}$$

$$5 \text{ metres per second or } 5 \text{ m/s.}$$

This time the unit is meter/second, it is also made up of two different units. So it is a derived unit.

Exercise



1. You must have seen the ants go in lines. Even if the lines are broken, after a while the ants make their lines again. Can you figure out how ants do this using the method of scientific inquiry?
2. Which of the six steps of scientific inquiry method do you think is most important? Why?
3. What is the difference between a scientist and science-minded person?
4. Suppose, you will open a grocery store on the moon. Would you use a physical balance (Daripalla) or a spring balance to buy and sell in that store? Why?
5. Hang a small stone with a long yarn or thread, shake it and find out how long it takes to swing. Now, by increasing or decreasing the length of the yarn and the mass of the stone, find out the time of swing. Is there any change in it?
6. If the temperature on Celsius (TC) is provided, you will be able to calculate the temperature on Fahrenheit (TF) by using this formulae- $TF = (TC \times 9)/5 + 32$. At a certain temperature, the value is the same in both the Celsius and Fahrenheit scales. Can you find out how much is the temperature?



Chapter 2

Matter and its Properties

Chapter 2

Matter and its Properties

At the end of this chapter, students will be able to know the following:

- ✓ Matter and the nature of matter
- ✓ Idea of mass and volume
- ✓ The difference between mass and weight
- ✓ Density, comparison of densities of different liquids
- ✓ Floating and sinking
- ✓ States of matter: The three states of matter (solid, liquid, gaseous) and their properties
- ✓ The use of properties of different states of matter in our daily life needs
- ✓ Physical and chemical changes of matter

Matter

What is matter?

Everything that you see and touch is matter!

The things that are only associated with our daily life are the things that we usually call matter. But, in fact, everything in the universe is matter. Some examples of known matters are pens, water, air or milk.

The only things that are not matters are the various forms of energy, such as light, heat, or sound. Matters have mass and volume. You may think that the air has no mass or volume, but you will see that the air also has mass and volume.

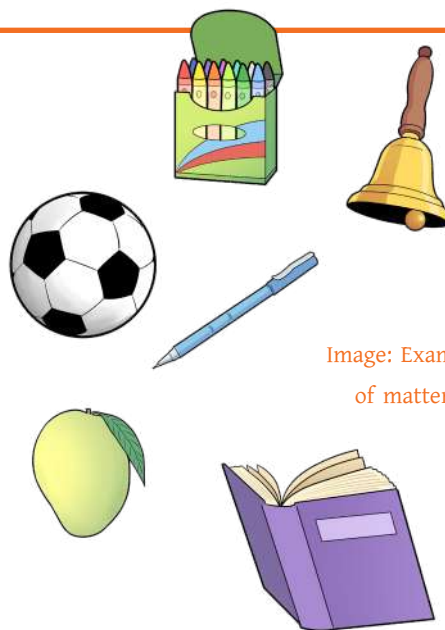

Image: Example of matters

Mass

Mass is the total amount of matter in an object. By looking at the balance scales shown in

the picture, you will get a better idea of what mass is. If both sides of this balance were at the same level, it would mean that the tomatoes in the left pan have the same mass as the iron object in the right pan. In that case, the tomatoes would have a mass of 1 kg, the same as the iron object. You have already read in the previous chapter that the international unit of mass is kilogram (kg).



Volume

Volume is a measurement of the space that a body occupies. How to measure the volume of an object usually depends on the condition or state of that object. You have already known that the international unit of volume is cubic-metre (m^3), but the smallest volume can be measured by cubic-centimetre (cm^3 or cc). The volume of a liquid is usually measured in litre (L). If the volume is small, it can be measured in millilitre (mL). One litre is actually equal to the volume of 1 thousand cubic-centimetre (1000 cm^3).

Density

Density refers to how much mass there is in a single volume. You have already known about mass. Let us think of an example! Suppose you fully load a box or a suitcase with your clothes. In fact, this box has a certain density. If we calculate the mass of the box and divide the mass by its volume, the result is the density of the box. Now if you take two or three clothes out of the box, the mass of the box will be reduced a little, right? But the volume of the box is not changing. So now if the mass is divided by its volume again, the density will be less than the previous calculation. That is, the density of the box is lower than before!

What does this mean? The more mass of object in the less space is, the denser the object will be. That is, the smaller the space, the denser the object. Therefore, density is a physical property of an object that expresses the relationship between its mass and volume. Since each object has a different density, many objects can be identified by the density. If you take a piece of iron in your hand, it will feel heavy, but if you take a piece of wood of equal size, it will not feel so heavy. This is because the density of iron is higher and the density of wood is lower.

In general, solids are denser than liquids and liquids are denser than gaseous substances. This is because the particles of solids are very close to each other; while

the particles of liquids can move around each other; in the case of gaseous matter, no matter how large space the particles are given, they are free to move throughout the space. If you know the mass of an object and its volume, then you can find the density of an object by dividing the mass by the volume. In other words, the density of an object is equal to the mass of one cubic-centimetre (cm^3 or cc) volume.

The unit of density is gram per cubic-centimetre, which is also written as g/cm^3 or g/cc . The density of iron is $7.8 \text{ g}/\text{cm}^3$. This means that the mass of iron per cubic-centimetre is 7.8 grams (g).

If you know the mass (m) and volume (V) of an object, then you can find out the density (ρ) of the object using the following equation.

$$\rho = m/V$$

If the mass of the object (m) is written in gram (g) and the volume (V) of the object is written in cubic-centimetre (cm^3), then the density (ρ) of the object will be found to be g/cm^3 unit.

If the volume of trunk of a mango tree is 2500 cubic-centimetre (cm^3), and the mass is 1500 gram (g), the density of wood of mango tree will be 1500 gram (g)/ 2500 cubic-centimetre (cm^3) = $0.6 \text{ g}/\text{cm}^3$.



The density of an object depends on two factors: The mass of an atom or molecule How densely the object is compacted

For example, the density of gold is high, because the mass of gold atoms is much higher and gold is made up of smoothly compacted atoms. Again, we know that the molecules of gas are scattered around to occupy the whole volume. As a result, there is a lot of space among the molecules. So the density of gas is low. The comparison of density among different matters is presented below:

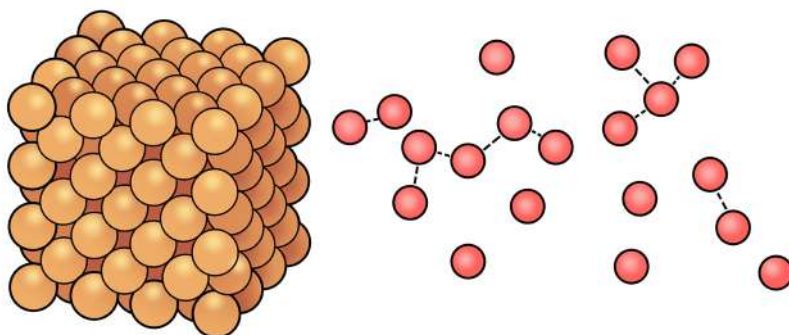
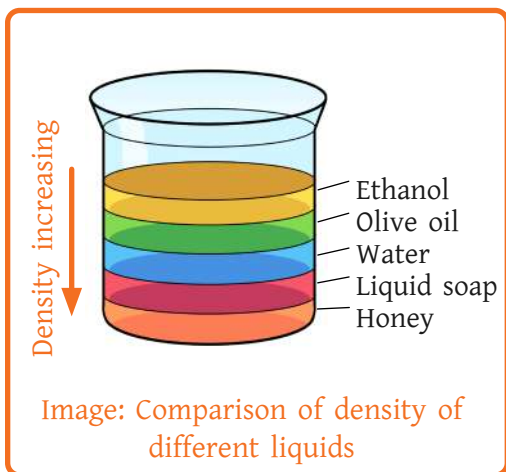

Image: The structure of gold and gas



Matter	Density (g/cm ³)	Matter	Density
Air	0.00129	Water	1.00
Cork	0.25	Iron	7.80
Glycerin	1.26	Silver	10.50
Ice	0.92	Gold	19.30

Table: A few matters and their density

Floating and sinking

Floating and sinking can be like a puzzle.

- ? Why does a lightweight aluminum coin sink in water?
- ? Why is a heavy mango tree trunk floating in the water?

You can certainly imagine that the floating and sinking of an object does not depend upon the mass of the object, rather depends on the density of the object. Since the density of aluminum is higher than that of water, aluminum sinks into water; since the density of the tree trunk is higher than that of water, the tree trunk also sinks into water.

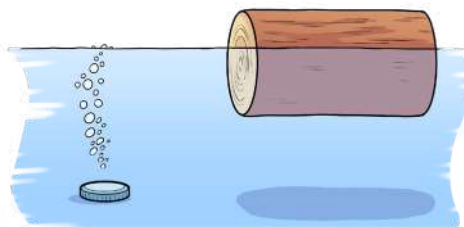

Interesting Information

- » Sea water is thicker than ordinary water. Due to that reason, it is easier to float in the sea than in the pond!
- » The density of water in the Dead Sea in the Middle East is so high that it can float without swimming!

Exercise



What do you mean by the density of an object as 1 g/cm³?
Write the reason: How do hot air balloons work?
(Clue: The density of hot air is different from that of cold air. That is why, hot balloons start to fly.)

States of Matter

We use different types of matters in our daily life. For example, wood is used in earthen stove (Matir Chula), kerosene is used in kerosene ovens, and gas is used in gas ovens. As you can see,

- ✓ Firewood is a solid matter
- ✓ Water is a liquid matter
- ✓ L. P. Gas is a gaseous substance /matter

That is to say, we can simply say that there are three states of matter, solid, liquid and gaseous.

Gaseous state and properties of gaseous matter

You have seen all kinds of solid matters around you, so you must have noticed that the volume of a solid matter does not change and its shape does not also change. Since the object is solid, in order to change its shape, various works have to be done on it.



Image: Examples of solid matters

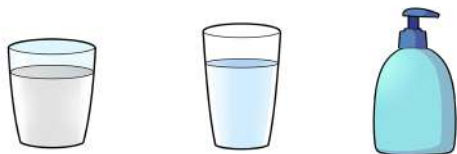

Image: Examples of liquid matter

Liquid state and properties of liquid matter

You have all used liquids like water, oil or milk in your daily life. You must know that although the volume of a liquid does not change, it does not have a definite shape of its own like a solid. When it is placed in the container, it takes the shape of that

container.

Gaseous state and properties of gaseous matter

We breathe in the air that surrounds us. Many vehicles run on natural gas or CNG. When water is boiled in a kettle, steam comes out from there. These are examples of gaseous matters. Both solids and liquids have specific volumes, but this is not true for gases. When a certain amount of gas is kept in a small container, it immediately spreads throughout the container; its volume

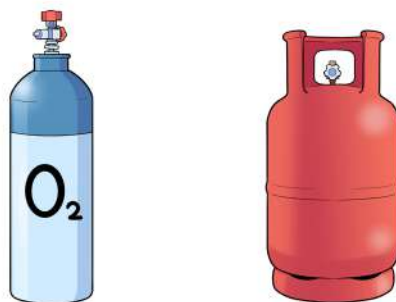

Image: Examples of gaseous matters

becomes equal to the volume of the container. Again, if the same amount of gas is kept in a large container, it will immediately spread to the whole large container; its volume will be equal to that of a large container.

Use of solids, liquids and gases

Because the properties of solid, liquid and gas are different, they are used in many different ways.



Image: A house and a boat, built by using solid materials



Uses of solid matters

As solid matters are solid, their shape is always the same. As a result, they are used to make houses, machinery, boats, etc.

Uses of liquid matters

Fluids, such as water and oil, are used in large quantities in our daily lives. Water is usually found in liquid form. Liquid water can be seen in Dighis, rivers, ponds, canals, drains and the seas. Oil is used as fuel for motor vehicles.



Image: Oil is used as fuel for motor vehicles.

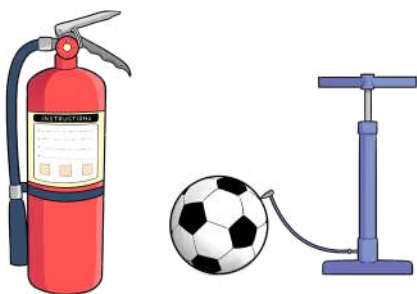

Image: Fire extinguisher nitrogen cylinder, and inflating football with the help of air

Uses of gaseous substances/matters

Gases are used for various purposes. For example, oxygen gas is used in treatment. Nitrogen gas is used to extinguish fires. Besides, inflating football with the help of air is also a use of gaseous matter.

Physical and chemical change of matter

The state of many matters changes in a natural way, while we change the state of matter in an artificial way for our needs.

There are two types of changes in matter: physical changes and chemical changes. As the very name suggests, physical change affects the physical or external properties of a matter and a chemical change affects its chemical properties. Some physical changes are two-way, such as heating an object and cooling it back to its previous state. Chemical changes are two-way in some special cases but usually they are one way.

Physical change

A physical change does not make a matter fundamentally different. For example, the process of making some fruit juice mixtures involves two external changes: the change in the shape of each fruit and the mixing of different pieces of fruit together. This is because there is no chemical change during the mixing of the ingredients in the fruit. For example, water and vitamins of fruit remain unchanged.

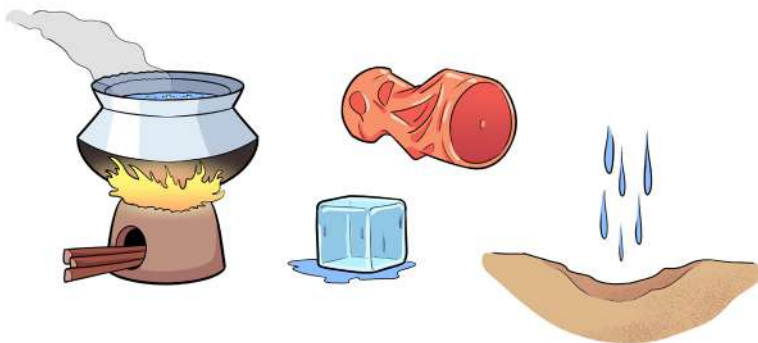
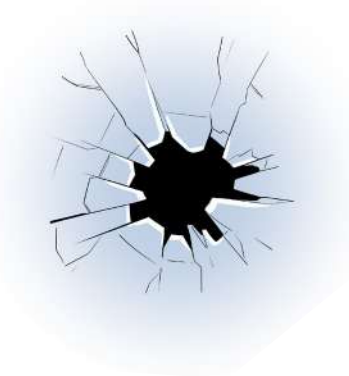

Image: Rolling, melting ice, boiling water, mixing water and sand, breaking glass are examples of physical changes.



Cutting, tearing, crushing and mixing are physical changes because they change shape but do not change the composition of materials. For example, a mixture of sugar and water creates a new matter without any chemical change.

Chemical change

As a result of chemical change, a matter is transformed into a completely new matter by changing the composition of the elements. Chemical change is also known as chemical reaction.

Rotting, burning, cooking and rusting are some of the other chemical changes. Because



they produce such matters or substances that are completely new chemical substances. For example, burning wood turns into ash, carbon dioxide, and water.

Image: Rolling, melting ice, boiling water, mixing water and sand, breaking glass are examples of physical changes.



Chapter 3

The Living World

Chapter 3

The Living World

At the end of this chapter, students will be able to know the following:

- ✓ Biodiversity or diversity in the animal world
- ✓ The smallest single cell in an organism and its structure
- ✓ Classification of organisms

Cell

Have you ever looked at the fingers of your hand and wondered what they are made of? Or the big tree in the school yard, or the fish in the aquarium in drawing room or in the well-known pond? Or how did they come to that shape and form?

All that we see around us and those who have life are known as organisms in scientific terms. We do not see all organisms or living creatures. We can see those that have been talked about above with our naked eyes. And there are some whom we do not see with the naked eye. They have to be seen with the help of special instrument. We will learn about this device in a little while.

Think of your school building. Whether one-storey or five-storey, this building is made of bricks one after another. So we can call bricks the unit to build the building. In the same way, there are some structural units at the root of the formation of small and big organisms that are unknown to us. Those units serve as the basis for the formation of your whole body, your favourite pet, or the trees of the field. In terms of science, these units of the structure of an organism are called cells. We will learn more about this in this chapter.



Cell: The smallest microscopic unit of an organism that is involved in the structure and function of the body of an organism is called a cell.

There are many organisms that are made up of only one cell. We call them unicellular organisms. All the biological functions of a unicellular organism take place in a single cell. Bacteria (Bacterium in singular and Bacteria in plural) and Protozoa are examples of unicellular organisms. Unicellular organisms are the simplest organisms.

The examples of the big organisms that you saw a little while ago (fish, trees, humans) are made of billions of cells. That is why they are called multicellular organisms. This very idea of a cell is something we didn't know about long ago.

Scientists have long been trying to figure out what the various organisms around us are made of. Many scientists have tried to find a way to examine life more closely. Thus the microscope was discovered in the sixteenth century. Using a microscope makes it possible to see even the smallest organisms that cannot be seen with the naked eye. The instruments of today's age are far more advanced than those of the early sixteenth-century microscopes, and are unraveling or opening up all the new mysteries of the living world day by day. From the smallest bacteria to the largest banyan tree or giant blue whale, cells are at the core of all organisms' structure and biological function. The human body is made up of 37 trillion (thirty seven trillion or 37,000,000,000,000) cells.

Larger organisms also have numerous smaller cells. If you look at different cells with a microscope, you will see that different cells have different shapes. Some cells are oblong, some are round or rod-shaped, and some may look like tadpole. There are some cells that do not have a definite shape, that is, their shape is changeable. Most of the plant and animal bodies of the living world are made up of numerous different types of cells. Cells are involved in a variety of physiological functions which are necessary for an organism to survive. In multicellular organisms, the shape of the cell varies depending on the function. In order for a multicellular organism to survive healthily, all types of cells need to be properly functioned and coordinated. That is, all the cells in an organism are dependent on each other.

Multicellular organisms are also made from a single cell. For example, the 37 trillion cells of an adult human started from a single cell which is called the undivided or primitive embryonic cell or Zygote. How did this one zygote finally turn into a huge number of trillion cells? The answer can be found by knowing the process of cell

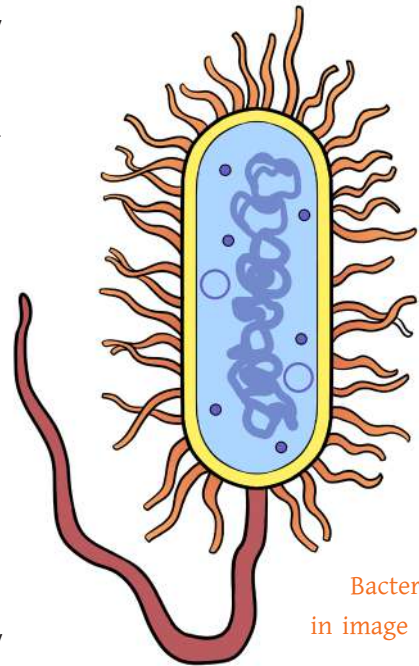

Bacteria
in image

division.

A mature body cell or somatic cell of a multicellular organism is divided into two at one stage. By doubling all its contents, including genetic materials, a cell divides itself to form two homogeneous cells. In each part all the elements move equally. In the process of cell division, new cells are formed from one cell to two, from two cells to four, from four cells to eight, from eight cells to sixteen and so on. Thus, as the number of cells increases, so does the body of the organism.

Suppose you have 20 trillion (20 lakh crore, that means 2×10^{13}) cells in your body now. But there were not always so many cells in your body. We have all started life as a cell. That cell has divided itself, grown in shape, and at one time divided again. We have grown from that childhood to the present day because our cells have been constantly getting divided.

Structure and function of cell



Each plant and animal cell has three main structures: Nucleus, Cell or plasma membrane, and Cytoplasm. The exception to this is the bacterial cell, which has no organized nucleus. The nucleus is usually round or oval. It is located near the centre of the cell. The nucleus acts as the control centre of a cell. Just as the brain of our body contains all the necessary information, so the nucleus is the centre of all the work of the cell. The information about the management of all biological functions, including cell growth, is stored in the DNA inside the nucleus. The nucleus has its own membrane, which separates it from the cytoplasm. The cell membrane surrounds the cell and controls the movement of various substances inside and outside the cell. The cell membrane of a plant cell is surrounded by a cell wall.

Plant and animal cells have a protective covering around the cytoplasm. This is called cell membrane. The cell membrane is flexible. However, in plant cells, there is a relatively hard covering around this membrane. This is called cell wall. Plant cells are a little harder because of the cell wall.

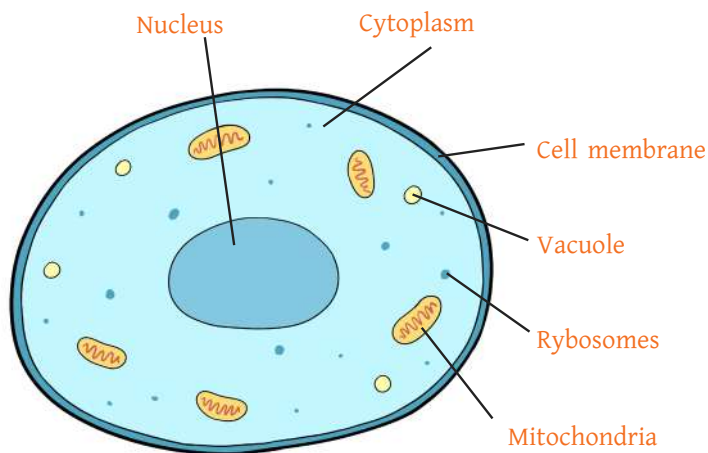

Image: Animal cells

The cell wall also shapes the plant cell. On the other hand, animal cells do not have a cell wall. Cellulose is a major component of plant cell walls. Cellulose is an inanimate element that protects and shapes cells. The main component of wood is cellulose. Only plant cells contain cellulose. Animal cells do not contain any cellulose.

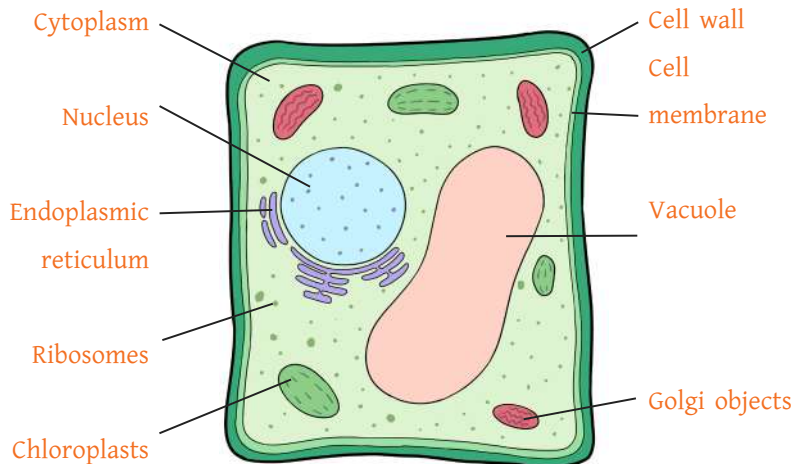

Image: Plant cells

In the beginning, we talked about different shapes and sizes of cells. How does a cell maintain its shape? Before answering this question, let me remind you that the skeletons of the animals play a key role in their structure and shape. For example, if there were no skeleton in the human body, there would be no such precise and specific structure. Again, some animals have a hard shell outside the body, such as lobsters. These shells also play a role in shaping the animal.

Our internal skeleton gives us precise shape and helps to keep the organs in the right place. Similarly, microscopic tube-like structures are observed inside the cytoplasm to maintain the shape of different cells and their organs. These are called microtubules. As we need food to survive, similarly cells also need to absorb or receive various elements. Just like us, cells have to get rid of cell wastes and toxins. Different types of cells perform different functions. The shapes of these cells depend on the types of work that they do. Plant cells have a large space called vacuole where water, waste and food are stored. This helps the plant keep upright. In case of dehydration in the vacuole, the plant falls down.

In multicellular organisms, cells do not work alone. Rather often a group of cells are engaged in a specific task. Cells that look same and participate in the same activity are

called tissues. Different tissues are named on the basis of work. For example, muscles, skin, bones, blood and nerves are different types of tissues in animals. Each of these is made up of different types of cells, and these cells are involved in a specific function of the organism. Unicellular organisms are much like large multicellular organisms in terms of function. Every cell has all such structures that help a whole organism to survive.

Characteristics of organisms

The earth is a lively planet. Here life is found in places that are beyond imagination. From the mouths of hot volcanoes at the bottom of the ocean to the acid-filled hot springs, tiny organisms can be found. Some years ago, scientists found microorganisms that had been living under dry rivers for 20 years in Antarctica. When the water reaches there, the vibe of life is created in just one day and in a week, they become a whole community! The question then arises in the minds of researchers, whether such existence of life can be found on the dry, cool surface of Mars! From these small facts, it is clear that biology is an interesting and sometimes surprising subject.

We can discuss the living organisms around us-whom we see or cannot see- in three parts- plants, animals and microorganisms. We will learn more about them in more detail just a bit later. But before that we will know about some of the common features of the organism. Organisms, whether plants, animals or microorganisms, have the following characteristics:

Acquiring and using energy

Every living organism needs energy to perform their biological functions. Plants absorb energy from sunlight and convert it into food. Again, animals receive energy from plants and other organisms.

Breeding

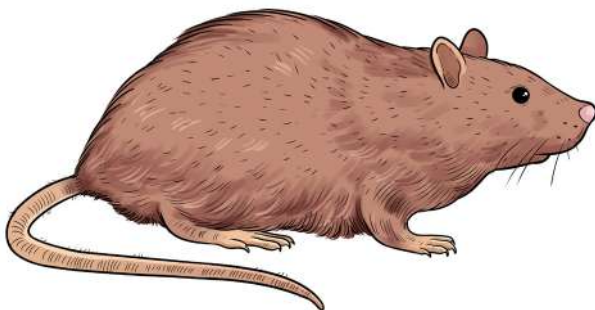

Organisms are capable of breeding or reproducing themselves. Many multicellular organisms, such as rats need father and mother to be born. Each of the parents provides a special cell. The two special cells combine to form a new cell. This cell later evolves into a new animal with the characteristics of its parents.

Growth and development

A seed becomes a full-fledged plant through germination and growth like the pea in the picture. Each organism has a specific life cycle that changes its size, shape, mobility and eating habits.

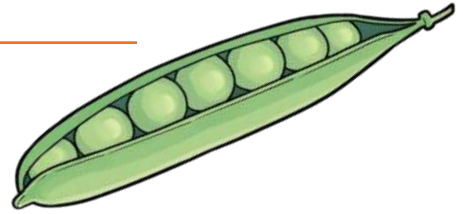

Response to the environment

Even

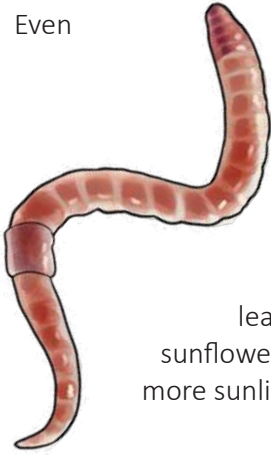

simple organisms or unicellular organisms are responsive to the environment. Have you ever noticed that when an earthworm is touched, it envelops its body?

The same thing applies to the leaves of Lajjaboti. Some plants, such as sunflowers, turn their faces to the sun to absorb more sunlight.



Classification of organisms

It is not possible to say exactly how many different kinds of organism there are on this earth. However, according to the latest estimates by scientists, this number is about 8.7 million or 87 lakhs. How can we recognize and know this huge number of different organisms? This thought made many people think. One solution to this thought was given by the Swedish botanist Carolus Linnaeus, also known as Carl Linnaeu (1707-1778). He developed a method of naming and classifying organisms. He divided the organisms according to their general characteristics. This method is still being used today. In this method, the organisms are classified according to their characteristics. The smallest unit of taxonomy is the 'species', which includes organisms with the most similar characteristics. Species refers to the most similar organisms of various characteristics, which are able to reproduce through reproduction within them, which may later produce offspring (children) with

similar characteristics to themselves. Similar species are grouped together into another unit called 'genus'. In the same sequence, similar genera (plural of genus) are included in the 'family'. For example, dogs, wolves, and foxes belong to the same genus. But they are different species. The family is the upper stage of the genus, and within the family, there is less similarity between the organisms than the genus. Families with the same characteristics are classified as 'order'. For example, dogs belong to the order Carnivora. Dogs, wolves, foxes belong to the same family; the order which dogs, wolves, foxes belong to, also includes cats, badgers and bears. Organisms of the same order are grouped into another unit called 'class'. The Carnivora order is part of such class that includes animals like bats, chimpanzees and whales. Many families form a 'phylum'. In this phase, dogs, birds, snakes, frogs and even fish come within same phylum. A few phyla

The image below shows the different stages of classification

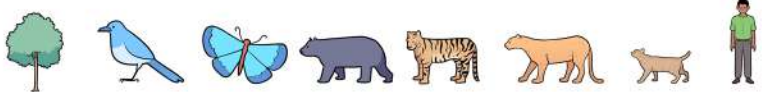

Domain: All of Protista kingdom, fungi, plants and animals belong to the Eukarya domain.



Kingdom: Animalia, kingdom of animals, consists of all animals.



Phylum: Animals belonging to the Chordata phylum have a hollow nerve cord on their backs. The spine is seen in many animals.



Class: Mammalia or mammals are vertebrates. These animals drink their mother's milk during infancy.



Order: Carnivora is a carnivorous group of all mammals that have well-formed teeth suitable for tearing meat.



Family: The animals included in the Felidae belong to cat family. Carnivores of this family have contractile claws.



Genus: Cats of Felis genus can't roar. They call out softly.



Species: Feliscatus species is very familiar to us. Domestic cats are members of this species. They can be easily distinguished from other members of the genus Felis for their *special features*.

(plural of phylum) combine to form a world or 'kingdom'. Kingdom is the most extended and largest phase. The modern scientists have reached this conclusion with proof that there are considerable differences among animals in the animal kingdom, due to which they need to be divided into different other kingdoms. This widely used classification consists of six kingdoms: Eubacteria, Archebacteria, Protista, Fungi, Plantae and Animalia.

Naming of the species

The scientist Linnaeus scientifically named the known organisms by using genus and species names which is also known as binomial nomenclature. The scientific name of most organisms is derived from the Latin language. For example, the word Carnivora is part of two Latin words. Carn means 'meat', Vorus means 'eater'. The scientific name for all domestic cats is Feliscatus.

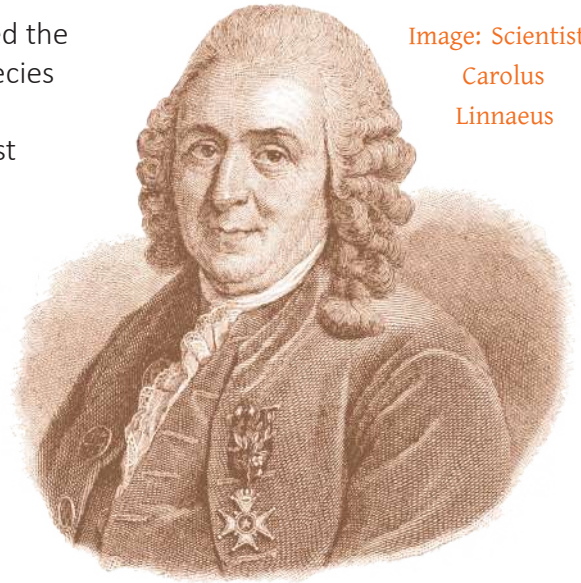

Image: Scientist
Carolus
Linnaeus

Exercise



1. Can you say which parts are necessary in the formation of cells?
2. Suppose you have discovered yourself a new species of fish, frog or insect! What will be the name of this new animal? Why?



Chapter 4

Plants, Animals and Microorganisms

Chapter 4

Plants, Animals and Microorganisms

At the end of this chapter, students will be able to know the following:

- ✓ The living world is divided into different groups on the basis of general observable characteristics, similarities and differences, such as: microorganisms, plants and animals.
- ✓ General comparative discussion on viruses, bacteria and fungi (formation, growth, merits, demerits)

Plant



Plants are an important member of the living world. Plants are essential not only as a source of food, rather for maintaining the balance of nature of the earth. Plants are of various kinds. But all plants have some common features. Here, we will know some details of plants.

Plants are such organisms having roots, stems, and leaves that produce carbohydrates using water and carbon dioxide in the presence of sunlight. The oxygen that is produced in this process is released into the environment by the plants. This oxygen has made this earth habitable for humans and other animals.

Why do plants need roots and stems? Think of a tall building. The water goes through one type of pipe to various parts of different floors of the building. The body of vascular plants has exactly the same vascular system. Vascular plants refer to such trees which have vascular tissues. These trees take water from the soil through roots. This water passes through the stems to the high branches

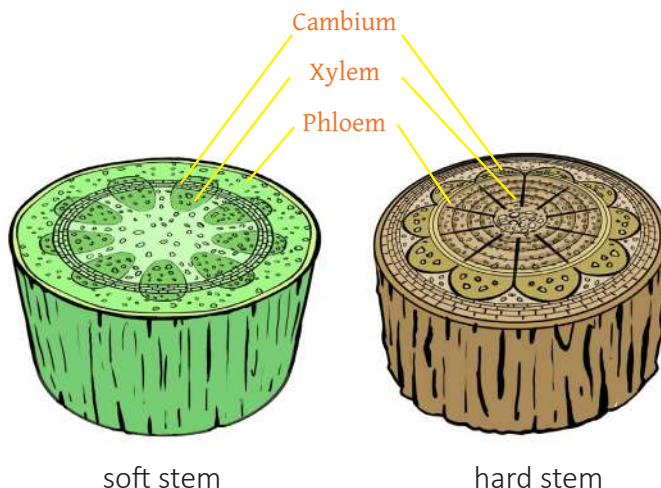
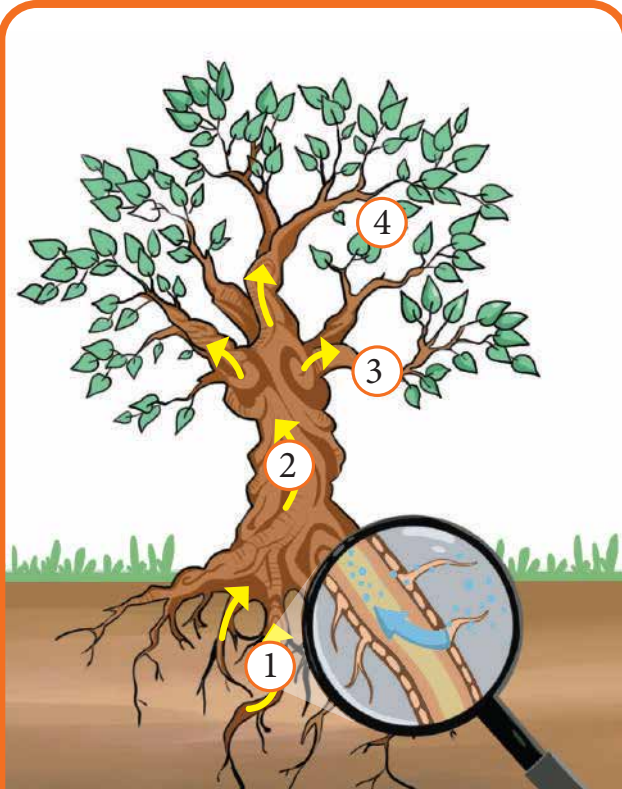

Image: Tissue arrangement of the stems of plants

and other organs. Xylem tissues are used in this process. Plants absorb water as well as mineral salts from the soil with xylem. On the other hand, Phloem is the name of the transport tube involved in carrying the food made from leaves. Phloem carries food to other organs including the roots. There is a cambium layer between this xylem and phloem, which separates these two types of conductive tissue from each

other. There is a cortex inside the covering of the roots and stems of the tree. The stems of a tree do the important work like holding the leaves by giving a structure to the tree. These stems can be of different types depending on trees or organs. What we see as a flower stalk is basically a kind of soft stem. The stems suitable to use as wood are very hard because of their thick outer bark. We get a delicious drink of sugarcane juice from the food stored in the juicy stems of sugarcane. Again, spiked cacti use their stems to store water.



How different elements are transported in trees –

1. Water and minerals from the soil enter the roots of the plant. Then, it travels through a cortex tissue to a vascular tissue called xylem.
2. Water and minerals come to the leaves from the roots through stems in the perspiration process.
3. Elements coming to the leaves enter every cell of the leaves.
4. The cells of leaves prepare carbohydrates using the carbon dioxide taken from water and air.

Root

The part of a tree that is connected to the soil, stores food, collects water and mineral nutrients from the soil is known as root. The root has a short hair-like part called root hair. The root hair is formed in such a way that it can easily absorb water and dissolved mineral salts from the soil in a large amount. There is a root cap at the tip of each root. It is basically the hard covering of the cell that protects the stem from injury. The part of the root that enters deep into the soil is the main root. Again, secondary roots spread close to

the surface. They make a vast network to absorb water. The water enters the roots from the soil and continues to flow towards the leaves through the stems because of the influence of fluid pressure on the root cells. Again, in the process of perspiration, water from the leaves of the tree is released into the environment through the stomata. The water continues to rise upward from the root through the xylem in order to fill the dehydration created as a result of water loss in this way

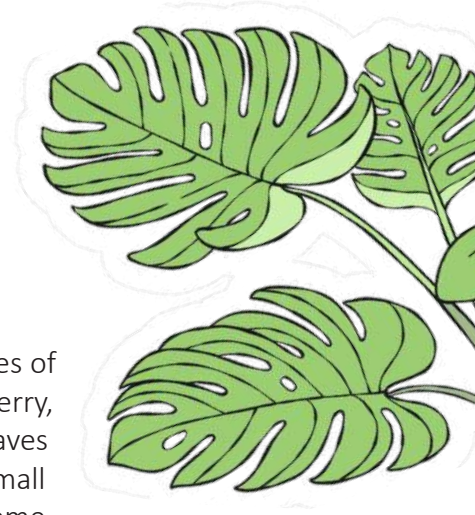

Leaf

The most noticeable part of a plant is its leaf. There are leaves of different colours, shapes and sizes. Mango, jackfruit, blackberry, banyan etc. trees can have single and simple leaves. The leaves of rose, neem, sajna (drumstick or moringa tree), etc. have small lamina. These are called compound leaves. The leaves of some trees are as thin as needles or in some cases spiked. The outer covering of the leaf is the epidermis. It is surrounded by a waxy covering called cuticle. Evergreen trees, such as pine trees, have green leaves all year round. The cuticle of the leaf prevents excess water from leaking out of the leaf in very cold or dry weather. The lower surface of the leaf has small pores called stomata. These pores are surrounded by guard cells, which control the release of water vapour and air from the tree. When there is enough water in the tree, the guard cells swell, and the mouth of the stomata opens up. When the temperature in the environment rises, the mouth of the stomata closes to reduce water loss. Trees lose excess water for perspiration. About 99% of the water absorbed

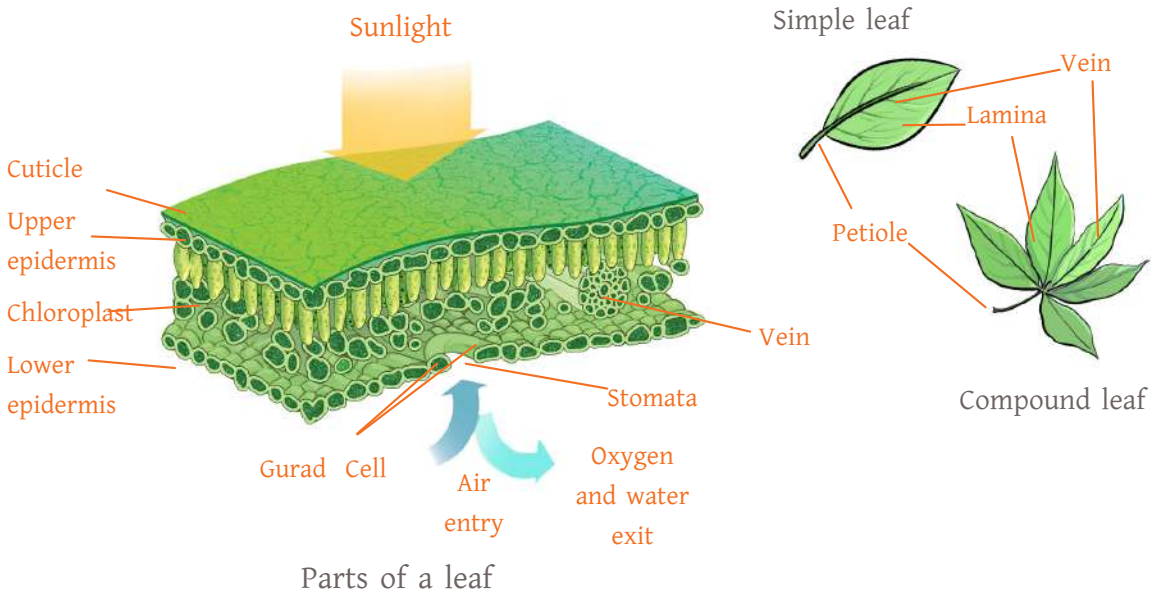

by roots returns to
the environment
through perspiration

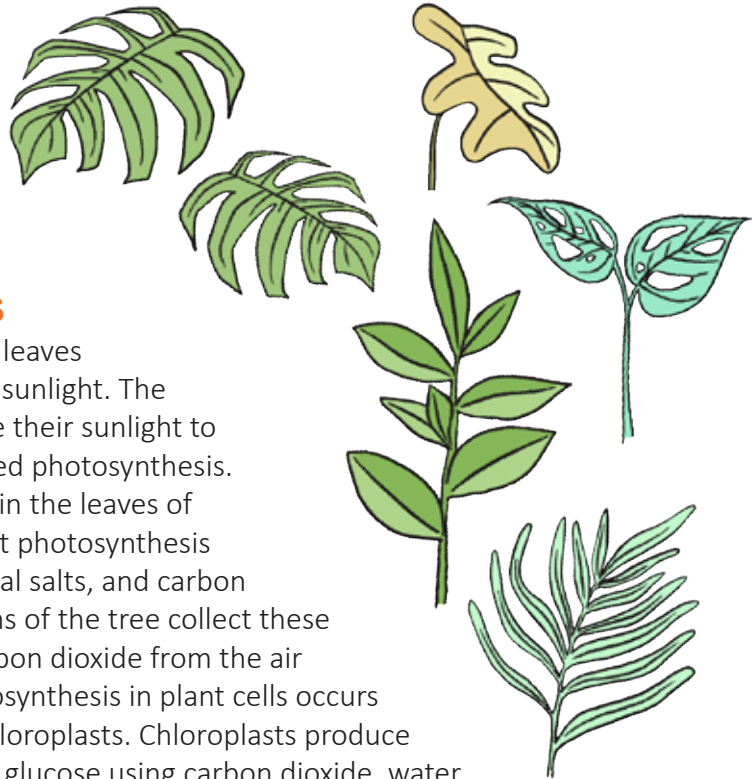

Photosynthesis

Most plants have large, flat leaves through which they absorb sunlight. The process by which plants use their sunlight to make their own food is called photosynthesis. Photosynthesis takes place in the leaves of trees. In addition to sunlight photosynthesis process needs water, mineral salts, and carbon dioxide. The roots and stems of the tree collect these elements. Trees absorb carbon dioxide from the air through the stomata. Photosynthesis in plant cells occurs in their organelles called chloroplasts. Chloroplasts produce food of trees in the form of glucose using carbon dioxide, water and solar energy. Oxygen is produced because of the process of photosynthesis. Trees release this oxygen into the environment quickly. Some of the produced glucose is stored in the leaves of trees. But most of it passes to stems and roots through the phloem and remains stored there. Birds and

animals that eat trees, tree leaves or fruits get energy from the glucose present there.

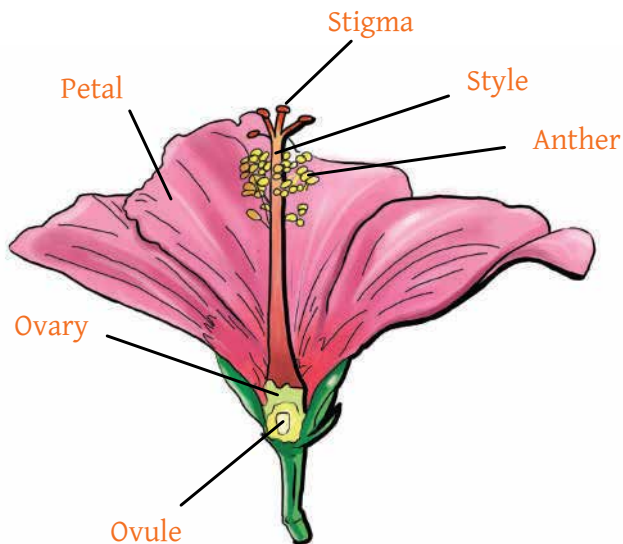

Reproduction of plants

All living beings reproduce. Reproduction is the process by which new generations of the same species are created. Reproduction can occur in various ways. In sexual reproduction, the union of male and female reproductive

Image: Different parts of a flower

cells produces new members. Again, in nonsexual reproduction, new generations are formed from just one type of cell. In some plants, animals and microorganisms both types of reproduction are observed.

Spermatophyte Plant

A seed is a structure formed in the life cycle of a plant that can give birth to new seedlings. Food is stored in the seeds. New trees grow from seeds in suitable environment.

Have you ever thought how seeds are formed?

Look at the following figure carefully. It shows the process of seed creation. Sexual reproduction occurs in spermatophyte plants. The microspore or pollen of the plant fertilizes the egg cell of the megaspore. The pollen grains are produced in the anther of flowers and egg cells are produced in ovary of flowers. Ovary is located below the style. Pollination is the process of transferring pollen grains from the male anther of a flower to the female stigma through air, bees or any other means. Pollination results in the union of the pollen grains with the egg cell. When pollination occurs between the same flowers or different flowers of the same tree, it is called self-pollination. Again, pollination between the flowers of two different trees is called cross-pollination. The medium used to exchange pollens between flowers is called pollen carrier, such as birds, insects, air or water. The pollen tube is formed when the pollen grains fall on the stigma. Through this tube, the pollen grains go down to the ovary. At one point, the pollen grains unite

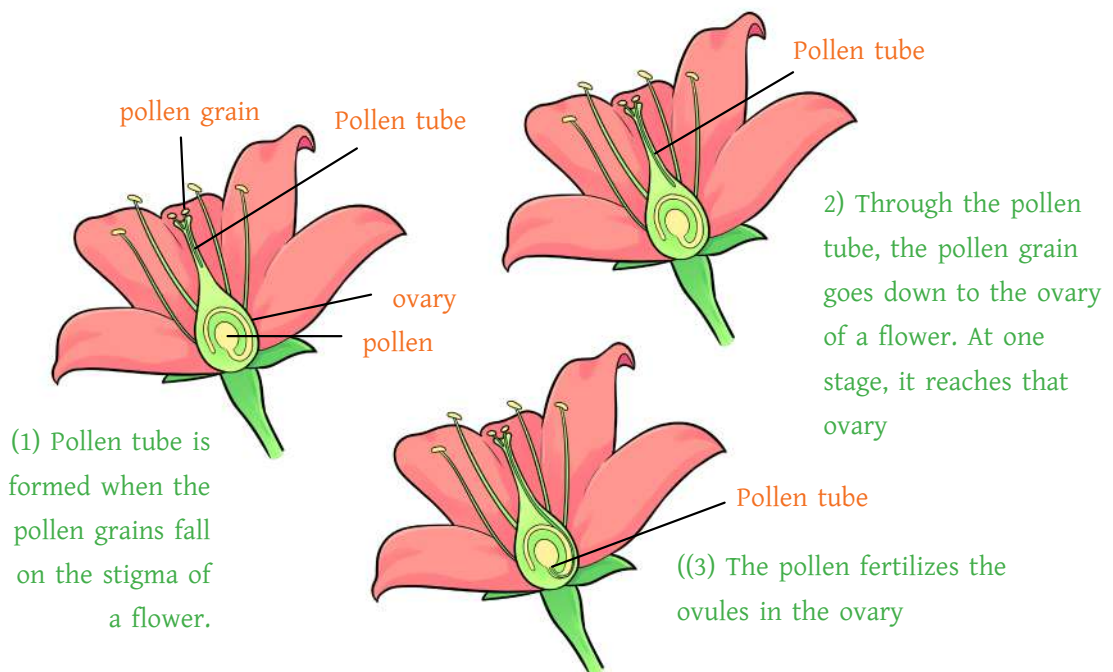

Image: Fertilization

with the eggs in the ovary. This process of union is called fertilization. Fruits and seeds are produced from the fertilized eggs.

Parthenocarpic Fruit Plant

Some plants do not produce seeds. In these cases, reproduction occurs through spores. Spores are a special type of small cell. Spores are formed inside the spore capsule. Conductive tissueless plants, such as algae, reproduce through spores. The use of spores is also seen in reproduction of some plants with conductive tissue.

Variation of seeds

Based on having a seed covering, plants can be divided into two types- Angiosperm and Gymnosperm. Spread of angiosperm plants depends on flowers. But it is not the same for gymnosperm plants. Seeds of gymnosperm plants are formed in the cone, such as the seeds of pine trees. The gymnosperm plants are the oldest plants. When there were dinosaurs on Earth, there were gymnosperm plants among terrestrial plants. These plants appeared on Earth about 250 million years ago. Angiosperm plants were not here even after about 100 million years of that time. Some gymnosperm plants are very small in size. The rest turn into very large plants.

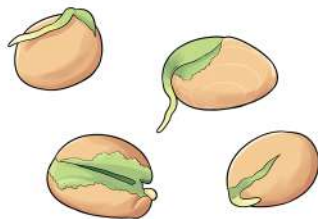
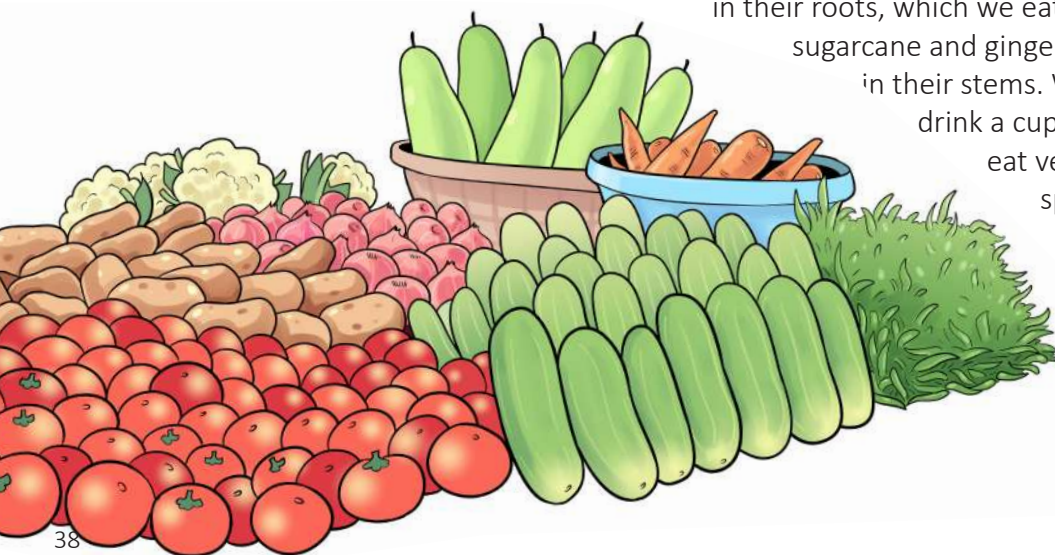

Image: Seeds of a jackfruit

Food Storage in Plants

When you go to the market, look at the fruits and vegetables. All fruits and vegetables come from plants, which store the energy from sunlight (light is a kind of energy. There are various forms of energy, such as sound, heat, electricity, etc.) as food.

Sweet potatoes (yam) and carrots store food in their roots, which we eat. Potatoes, sugarcane and ginger store food in their stems. When people drink a cup of tea or eat vegetables like spinach or cabbage, they



basically eat leaves, leaf extract in case of tea. Cauliflower and broccoli are basically flowers which we eat. We even eat seeds such as- bean sprouts, rice, nuts. The seeds of the plant are rich in nutrients because the food is stored in the seeds.

Animal



Have you ever been to a zoo? If you have not visited, think of the animal you like most. Do you notice any special difference among these animals?

Vertebrates

There are many kinds of animals in the world. For example, your pet cat has a strong spine or backbone. You also have a backbone along the middle of your back, which helps you to walk straight. Again, there are many animals that do not have such a structure. For example, worms. Surely, you have seen how the worm moves on its chest. Vertebrates are animals that have a backbone divided into different parts. Vertebrates are divided into seven classes. This group also includes the animals of land environment and the largest marine creatures.

Classification of vertebrates



Vertebrates are animals with nerve cords. A nerve cord comes down along their backs. These animals are basically known as chordate. The backbone protects the nerve cord. Vertebrates have an endoskeleton for their protection and movement. This endoskeleton is formed with bones and cartilage. Cartilage is a soft, bone-like element that grows with animals. Vertebrates include reptiles, amphibians, birds and mammals. Some mammals are tetrapod animals, such as cows, goats, cats, dogs, etc. Others are bipod animals, such as humans. Different types of fish also populate the classes of vertebrates.

Seven classes of vertebrates

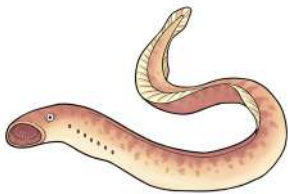

1. Jawless fishes

About 70 species of fish have been found that do not have jaws. Hagfish and lamprey are some of among them. The skeletons of these fishes with gills are very flexible.

2) Bony fishes

There are about 20,000 species of fish that have well-formed skeletons. Their skeletons have a bony structure. These skeletal fish with hard bones use gills for respiration (breathing). Rui, Hilsa etc. are notable examples of this class.

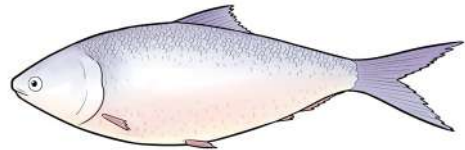

3) Cartilaginous fishes:

Skeletons of sting rays, sawfish and various species of sharks are formed with soft cartilage. They also have well-formed gills for respiration. There are about 750 species of cartilaginous fish.

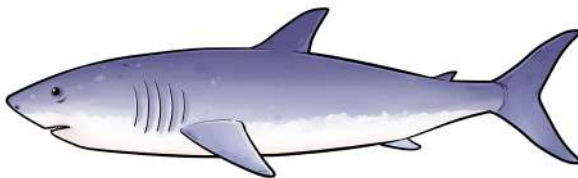

4)

Amphibians

Amphibians have a special body structure to live in both water and land. At a young age, they perform their respiration with gills while in the water. But while living on the ground in their adult age, they run respiration through the lungs. These animals have hard jaws, smooth skin and bony skeleton. Frogs and salamanders are the most widely known among about 4,700 species of amphibians.





5) Reptiles

The main characteristic of reptiles is that they crawl. There are about 8,000 species of reptiles including lizards, chameleons, crocodiles, turtles, and snakes. Some reptiles live in water. Again, some live in land. They have well-formed lungs and hard bony skeleton covered with fibrous skin.



6) Birds

About 9700 species of birds have been found. Most birds can fly, with the exception to ostriches. Birds are quite light because of hollow bony skeleton. They can fly with the help of feathered wings. Birds have lungs. Crow, sparrow, pigeon, wagtail (doel), eagle etc. are notable among our most familiar birds.



7) Mammals

Most mammals including human, dog, cat, elephant, horse, tiger, bear and hippo live on land. But whales also live in the sea though they are mammals. Mammals drink breast milk in infancy. They have the most advanced characteristics. Their bodies are hairy. Bony skeletons form their bodies. They can eat a variety of foods because of their well-formed jaws. About 4700 species of mammals have been identified so far.



Invertebrates

In easy words, invertebrates are the animals without backbones. Vertebrates are widespread in all environments, but they are not the highest in number. More than 95 percent of all animals are invertebrates. Invertebrates live in a variety of environments. They are found in deserts, at the bottom of the ocean, and even inside other creatures. Arthropods are the largest group of invertebrates, which have more than one million species. These include insects, spiders, crabs, shrimps, etc. Flatworms and roundworms live in water, in moist soil or inside other animals. They have a common structure. The bodies of some insects are divided into different parts, such as worms. This is not seen in case of flatworms or roundworms. Most of the insects with body parts like worms live in moist soil. Again, some insects can live in aquatic environments, such as leeches. Jellyfish and corals belong to the class Cnidaria. They have cells with special characteristics, which they use to catch fish and other creatures. Hydra and marine anemones also belong to the class Cnidaria. Sponge belongs to the phylum Porifera. They are of different colors. Sponges attach

themselves to the bottom of the ocean and receive tiny particles from water. Oysters and snails belong to the phylum Mollusk. Most mollusks live in water. But some animals also live on the ground, such as snails.

Arthropod

Arthropods are invertebrates whose exoskeleton is hard in nature and works to protect internal organs. The exoskeleton does not grow with the growth of the animal. As a result, as the animal grows, it must be released from the body. Arthropods also have articulated legs that help them to move. Their bodies are divided into several special parts. The three largest groups of arthropods are crustaceans, insects and arachnids. Crustaceans live in freshwater or salt water or on land. Arachnids are probably the first animals to live on land.

Crustaceans

Crabs, shrimps and lobster are the examples of crustaceans. Crustaceans have more than 30,000 known species. They are found in large quantities in the sea.

Insects

The largest group of arthropods is the insect, which contains more than one million species. The body of the insect group are divided into 3 parts namely head, thorax (chest) and abdomen.

Three pairs of legs are attached to their thorax. The antennae and eyes help the insect to understand its surrounding environment.

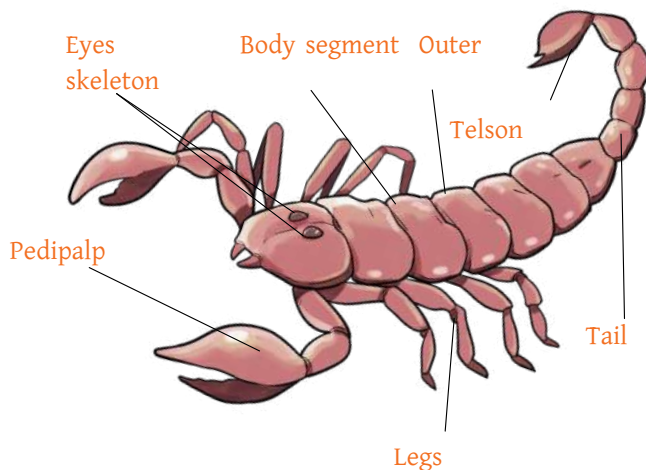
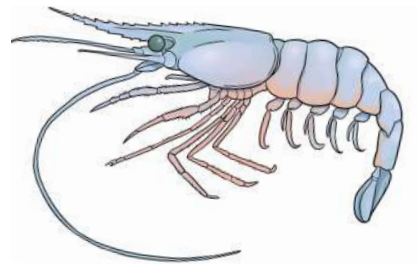

Arachnids

Arachnids include spiders, ticks, scorpions and mites (a louse-like creature). They have four pair of appendages, one or two body parts. They have no antenna. Spiders are a type of predator that depends mainly on

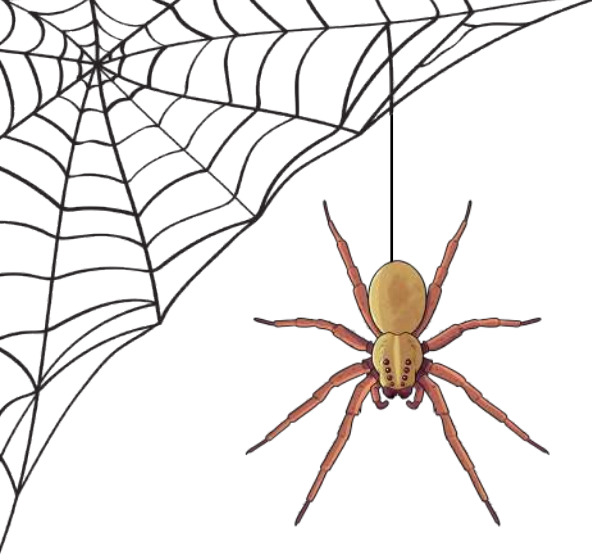

eating insects. All spiders produce strong silk fibers. Some spiders catch their target by weaving this silk net.

Microorganisms



Microorganisms are living beings that cannot be seen with bare eyes. Microorganisms can be unicellular, meaning they have only one cell. Some microorganisms are multicellular, which have more than one cell. Microorganisms need food, air, water, means of excretion and the environment in which they can live. Some microorganisms are producers, meaning they make their own food from simple substances using sunlight (like plants). Some microorganisms are parasites/ consumers. They cannot make their own food; they depend on other organisms for food. Most microorganisms do not cause disease; rather many microorganisms act as helpers to us. There are different types of microorganisms. Scientists have classified microorganisms like plants and animals. These classifications are determined by the size, structure, food source, habitat, and movement of microorganisms. These microorganisms include bacteria, fungi and protists.

Bacteria

Bacteria are the most diverse and abundant fauna in the world. People did not know about bacteria for thousands of years. In the last half of the seventeenth century, Anthony van Leuwenhoek, a Dutch merchant, used a simple microscope to observe the scraping of his teeth. Leuwenhoek did not know that the tiny creatures he saw there were bacteria. 200 years later it was proved that bacteria also have life. They live in almost all environments. They are found in the sea, on land and in animals and even in the human intestines (both small intestine and large intestine). They are also found in deep rocks beneath the earth's surface. Any surface that has not been disinfected is likely to be covered by bacteria. The total number of bacteria in the world is stunning. It is estimated to be five million trillion trillion (thirty zeros after five!) There are more bacteria living in your body than there are cells. Bacteria grow up to a certain size and then reproduce in mitosis process. This occurs when a mother cell divides itself into two same daughter cells. It can result in a

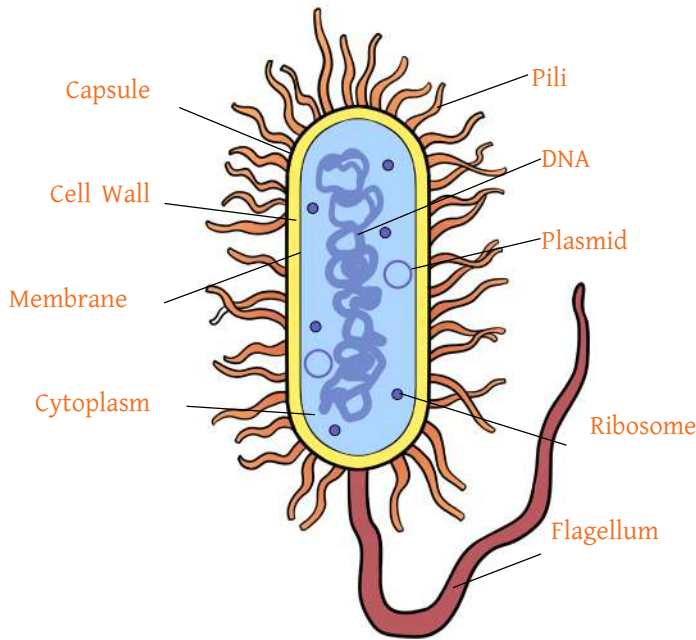

Image: Bacteria

rapid increase in the number of bacteria. For example, in an ideal environment, the number of bacteria may double in every 20 minutes. This type of rapid increase helps bacteria to adapt to an unstable environment. Bacteria are divided into two kingdoms- eubacteria and archaebacteria. Eubacteria or "real bacteria" can live almost everywhere, such as soil, water, air and even your body. Archaebacteria, meaning "primitive bacteria" can live in a very hostile environment, such as hot spring, volcanic eruptions at the bottom of the ocean, and extremely salty environments.

Some Archaeobacteria are classified on the basis of their place of origin. Eubacteria are classified according to size, such as rod, round or spiral. Round eubacteria can grow in clusters or long chains.

Fungus

What is a fungus? Have you ever seen something bluish green growing on bread? These are fungi. A fungus is an organism that belongs to the kingdom of Fungi (singular: fungus). They are not animals or plants. As a result, they cannot perform photosynthesis and take food through absorption. Most fungi are multicellular, but some are unicellular. There are different types of fungi, such as yeast, mold and mushrooms. There may be about 1.5 million species of fungi. You can easily see bread molds and mushrooms without a microscope. But you cannot see most of the fungi with bare eyes. Fungi live in different environments where you cannot easily see them, for example, deep in the soil, under the decayed trunk of trees, or inside plants or animals. Some fungi can live inside or on top of other fungi. Fungi are very important

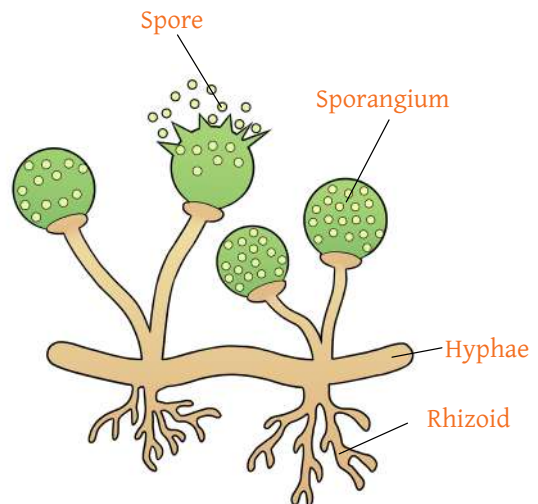

Image : Fungus

for our environment. The fungus helps to produce nutrients by decomposing various substances and to produce nutritious food for other organisms. Fungi are all around us and they are helpful to us in many ways.

Protista

The organisms of this kingdom are unicellular like bacteria or often look like fungi. They look for food like animals or perform photosynthesis like plants. They have so many similarities, but they have no similarities with bacteria, plants or fungi. Protists are a large and diverse class of eukaryotic organisms. The eukaryotes that make up this Protista kingdom do not have so many similarities with the animals of other kingdom. They are relatively simple in nature. Protists are structurally very different from each other. Some of them are small and unicellular like amoebae. Others are large and multicellular like seaweed. However, multicellular protists are structurally simpler than plants.

Animal-like Protist

These are unicellular eukaryotes that have a number of characteristics of animals. They can move like animals, and they are heterotrophic. That is, they depend on other sources of food instead of making their own food.

There are different types of animal-like protists. Animal-like protists are divided into the following groups based on their locomotory organ and the nature of their locomotion:

(1) **Pseudopods:** Their cell surface extends to form a temporary structure like legs that moves the cell forward.

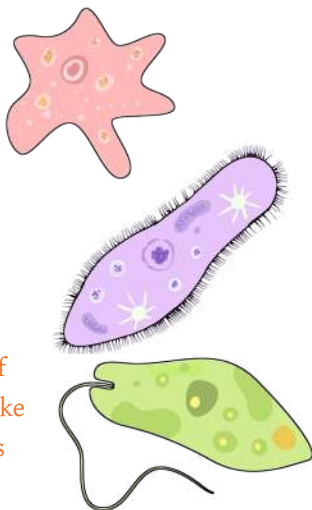

Image:
Three
types of
animal-like
protists

(2) **Ciliate:** They have a thin, hair-like projection called cilia which extends outward from the cell body. These protists change position through cilia contraction and expansion. Paramecium moves through the cilia.

(3) **Flagellate:** They have long flagella. The flagella

fly
like
a fan and help the protist
to move through the environment.

Plant-like protists

They are known as algae. They are a large and diverse group. Plant-like protists are autotrophs or producers. That means they can make their own food. Like plants, they can produce carbohydrates through photosynthesis using carbon dioxide and water in the presence of sunlight. However, they do not have real stems, roots or leaves like plants. Most plant-like protists live in seas, ponds or lakes. Protists can be unicellular or multicellular. Seaweed and kelp are examples of multicellular, plant-like protists. Kelp can grow like plants in shape and make a "forest" in the sea. Such protists are essential for the ecosystem, and they are the foundation of marine food-chain. They produce the oxygen needed for the respiration of animals through photosynthesis.

Fungus-like Protist

Many characteristics of the fungus are similar to fungus-like protists. They both are heterotrophs, meaning they are unable to make their own food. They depend on other organisms for food. Some

Why are algae considered to be like plants?



This is thought because of the presence of chloroplasts and having the process of food production through photosynthesis. Even then, algae do not have many things of the actual plant cells. For example, algae do not have roots, stems or leaves. There are algae, which are able to move too. They can move with the help of Pseudopod or Flagella. As a result, they are quite different from plants. Algae themselves are not plants but they were probably the ancestors of plants

other notable similarities between these protists and fungi are the presence of cell walls and reproduction using spores. These protists are generally unable to move, but some protists have been found to be able to move at some point in their life cycle. Two examples of fungus-like protists are slime mold and aqueous mold.

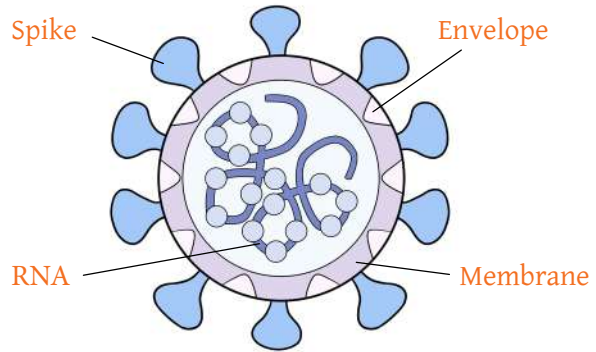

Image: SARs-CoV-2 virus

Virus

We all know about the SARs-CoV-2 virus now- the cause of COVID-19. What is a virus? A virus is not an organism. They are not formed with cells and have no source of energy; meaning, viruses are not microorganisms. Viruses are basically genetic materials- DNA or RNA wrapped with protein covering. These tiny organisms cause a variety of diseases. The virus is also responsible for our most well-known disease common cold. Viruses do not have any cell, so they do not have any cell membrane, cytoplasm or ribosome like other cells. Now the question is, is the virus alive? We know that all living things have cells, and they are also capable of reproduction. But viruses cannot reproduce on their own. A virus is an entity that takes control of the cells of another organism. The cells infected by the virus are called host cells. Once a virus enters a living cell, it signals an increase in its number in the cell. Then, the cell is damaged or fractured and the viruses are released. Each new virus can then capture a new host cell. Host cells can produce up to 10 billion similar viruses in a single day. Imagine if a virus had the size of a coin, 10 billion viruses could fill an entire football field to a depth of more than 1 meter (3 feet) in one day. During infection, the virus uses the host cells to replicate their own DNA or RNA. For this reason, most scientists do not consider viruses to be living things.

Exercise



1. Can you tell the names of the animals shown in page number 39?
2. Which animals except humans can walk on two legs?
3. Have you noticed the white layer like gray cotton on the food left for some days or on the food kept in the fridge? Can you say what they really are?

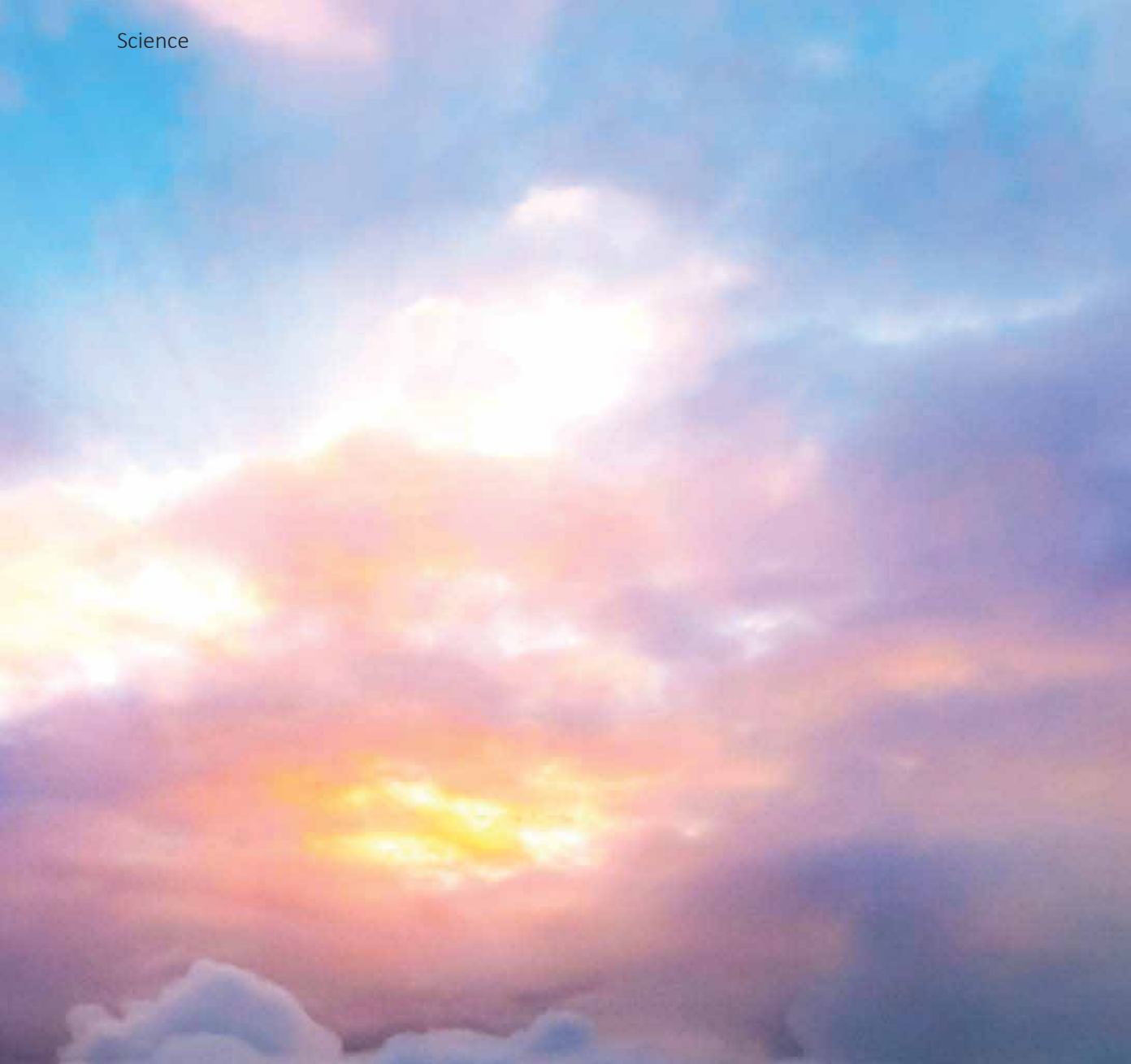

Chapter 5

Weather and Climate

Chapter 5

Weather and Climate

At the end of this chapter, students will be able to know the following:

- Weather forecast based on insolation, rain, air pressure, humidity in the air etc.
- Greenhouse gas and greenhouse effect: causes and remedies
- Acid rain
- Ozone layer depletion
- Man-made effects on climate

Weather and Climate

You must have read story books wrapping yourselves with a quilt in bed sometime in the afternoon when the school breaks up early in winter. If there is a window next to the bed, you will see the sun shining on the bed through the window everyday at noon. In the winter afternoon, you will see sunlight and heat (which we know together as insolation) spread over most of the bed. Again, during summer, you will see the sunlight taking up much less space on the bed. Not only that, the direction of sunlight has also changed. In summer the sunlight falls on the bed at a much lower angle than in winter. In winter, sunlight falls on most parts of the bed, but much less heat is available than in summer.

Similarly, in summer or rainy days, when it rains heavily, some time (a few hours or days) before the rain, we feel very hot. All these things happen because of different changes in the weather.

Weather

Weather and climate are two familiar words in our daily life. Weather reports are a part of the daily television news. We also see daily weather reports on the radio, in daily newspapers and even on smartphones. These weather reports contain the

following issues:

- ☑ Insolation
- ☑ Rain
- ☑ Air temperature
- ☑ Humidity of air
- ☑ Direction of wind flow
- ☑ Air pressure etc

These are called elements of weather. Depending on different qualities of weather, we can understand what the weather would be like.

Insolation



The main source of energy on earth is the sun. This energy comes from the sun to the earth in the form of heat and light. This is called sunshine or insolation in English. Different amounts of sunlight come to the earth at different times of the year. It depends on how long the sun stays in the sky and how clear the sky is. Now, can you tell me at what time of the year (month or season) the sky is clear and blue for a long time and when it is cloudy?

Similarly, the amount of sunlight depends on how long the sun is in the sky. If the sun is in the sky for a long time, naturally the earth's surface of that place will get more sunlight. The earth's surface here refers to the earth's soil, water, and air. If the sun shines less time during the day in the sky, the earth's surface will get less sunlight. The sun rises late and sets early in winter. As a result, the duration of the sun's shine in the sky is shortened. The Earth's surface is relatively cool due to getting sunlight for a shorter period. So, tell me at what time of the year the sun stays in the sky for a long time? What will be the temperature of the earth's surface then?

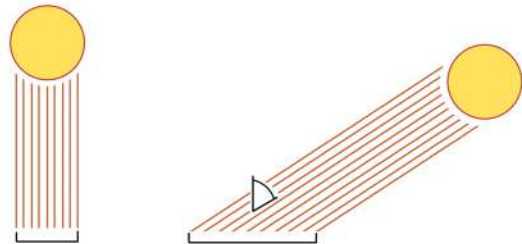

Image: The angle of the sunrays is changing in summer and winter
Image: The angle of the sunrays is changing in summer and winter

If the insolation stays for a long time and is intense, the amount of evaporation in that place also increases

Air temperature



We feel hot in the shade or in the house without going out in the sun in summer. This is because the air temperature around us is higher then. This temperature depends on:

- » **The angle of sunlight falling on the ground:** If the angle is greater (90 degrees or closer), the amount of sunlight and heat is more, and the surface and adjacent air is hotter. Again, in winter, the intensity of sunlight decreases because sunlight falls on the surface at a lower angle. As a result, the air temperature drops and we feel cold.
- » **The time of the presence of sunlight:** Notice at what time between summer and winter the sun is seen for a longer time in the sky. If the sunlight is present in a place for a longer time, the air in that place will be hotter.
- » **The amount of water vapour in the air:** Water vapour can hold more heat. As a result, if the amount of water vapour in the air of a place is higher, it will be hotter there.

Air temperature is measured with a thermometer.

Rain



Rain is one of the elements of weather. There is a lot of rainfall in Bangladesh at different times of the year, especially during the monsoon. Numerous drops of water of different sizes fall from the sky. Where did this water come from?

Now let's look at some facts. Water vapour is seen rising from the pot when we cook rice in the oven or heat the water. Again, if the wet cloth is spread on the rope, especially in the sun, it dries. Where does this water go? This water gets mixed in the air. Similarly, in the presence of sunlight during the day, a large amount of water evaporates from the soil, water and plants located on the earth's surface and mixes in the air. But this water vapour in the air cannot be mixed in an indefinite amount. The ability to hold water vapour in the air of any place is limited and it depends on the temperature of that place. We can compare it to a glass of drinking water. A glass has a fixed capacity of holding water. Therefore, if water is poured into the glass as we wish, the excess water of the capacity of the glass overflows the glass. In the case of air at the earth's surface (this layer of the Earth's air is called the atmosphere), when the amount of water vapour in the air of a place exceeds the capacity of the air there, that excess water vapour condenses into small particles of liquid water and returns to the earth's surface. Rain is just one of the many forms of the returning water. In this case, when water vapour rises above the earth's surface, it gradually cools and condenses. Then, at first it turns into clouds (which can be formed with very small

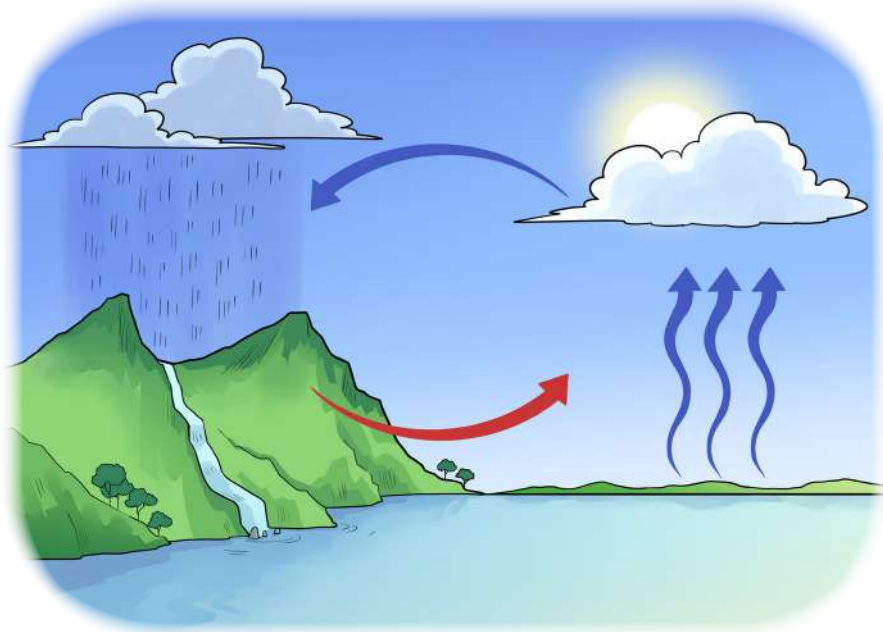

Image: Origin of rainfall and its change

liquid water particles and even ice particles) and then raindrops. When small particles of water condense into bigger water particles, they can no longer float in the atmosphere and fall in the form of raindrops. Later, it flows into the sea through rivers, ditches, canals, beels etc. The device used to measure rainfall is Rain Gauge.

Air pressure



Earth's gravitational force influences the air around us. As a result, it also has a weight and this air applies pressure on everything it touches.

Air pressure is the force per unit of an area applied by the atmosphere on any object or place on the earth's surface. This pressure is applied in all directions. If we fill a glass to the brim with water and stick it with a piece of hard paper or cardboard on its face and flip the glass over, it will be seen that the water is not falling even though the glass is upside down with water. This happens because the air applies pressure from all directions. When we dive into water, we feel the pressure on the parts of our body under water as water is much heavier than air. The atmosphere is also putting pressure on us which

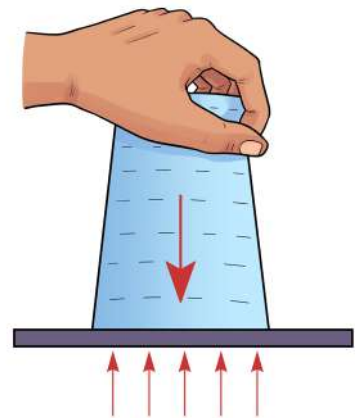

Image: Experiment of air pressure

we do not easily feel. However, when we go to a very high place or when we travel by plane, we can feel the change of air pressure. This air pressure is very important in weather forecast. The unit of air pressure is Millibar. The average air pressure is 1013 millibars. If the air pressure is higher than this, it is called high pressure and if it is low, it is called depression (low pressure). If the air pressure decreases or if there is a depression, it indicates the possibility of storm and rain. The name of the device used to measure air pressure is Barometer.

Air pressure depends on the following factors:

- » **The variation of altitude from the sea level:** The higher we go, the lower the air pressure is.
- » **The variation of air temperature:** If the temperature of air increases, the air pressure decreases and when the temperature decreases, the air pressure increases. Due to this in winter the air is relatively dry and heavy and high pressure is observed.
- » **The variation of water vapour in air:** If the temperature of the air increases, the amount of water vapour in the air also increases. As a result, the air pressure decreases and the barometer shows depression (less than 1013 millibars). This is because the amount of water vapour in the air increases and the air becomes moist which is lighter than dry air.
- » **Earth's rotation speed:** The earth rotates on its own axis from west to east, which is called rotation speed. As a result of this, there is relatively more depression in the equatorial region.

Direction of wind flow



Weather forecast depends on which direction the air is flowing. For example, in winter in Bangladesh cool air flows from the north and it decreases the air temperature. Again, warm and humid air blows from the southwest during summer and monsoon. Due to

the presence of more water vapour, this air causes heavy rainfall. The name of this air is monsoon wind. The name of the device used for showing the direction of wind flow is called Wind Vane.

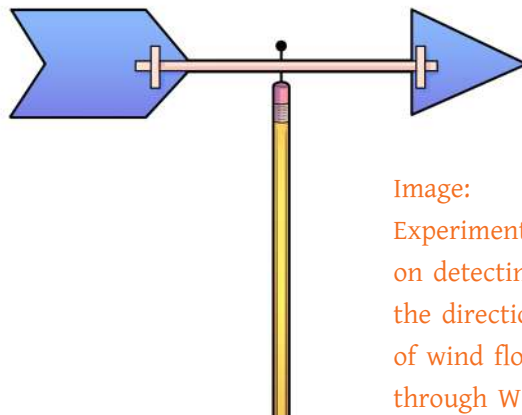

Image:
Experiment
on detecting
the direction
of wind flow
through Wind
Vane

Humidity of air



Humidity is the presence of water vapour in the air per unit. There are two ways to measure this humidity, namely-

- **Absolute humidity:** Absolute humidity refers to the actual amount of water vapour in the various gaseous elements in the

air.

Relative humidity: Relative humidity is the percentage of water vapour in the air compared to the maximum amount of water vapour a place can hold at a given temperature. If the relative humidity in a place is said to be 100%, then it is to be understood that no more water vapour can be added to the air of that place. If the humidity of a place is high, wet objects cannot be easily dried there.

Humidity is measured using a Hygrometer.

Climate

Climate is the average weather for a given period of time in an area. Understanding the climate of an area requires information on various elements of the weather for at least 30 years. Temperature and rainfall are the two main elements of knowing about climate. In this case, it is important to keep in mind that all the elements of the weather are also the elements of the climate (insolation, rain, temperature, humidity etc.).

The three things that climatologists consider to explain the climate of an area are:

- (1) What is the average temperature of that place?
- (2) What is the average rainfall of that place?
- (3) What are the changes in temperature and rainfall in different seasons there?

So, by climate we mean the pattern of changes in different elements of the weather of an area over a period of several years (30 years or more). Climate change is caused by a variety of natural and man-made reasons. In many cases, such change causes harm to humans and other living things. The burning of fossil fuels, greenhouse gases emitted from factories and various vehicles are greatly involved in climate change. In that case, countries with more factories and oil and gas-powered vehicles emit more greenhouse gases into the atmosphere. This emission of greenhouse gases is more

responsible for climate change.

Greenhouse effect

The greenhouse effect is a process that causes the earth's atmosphere to become warmer compared to what it would have been without this effect. The term comes from the kind of a house called a greenhouse, made of glass or other transparent materials and used for farming in cold countries. Greenhouses re-radiate the heat and light they receive from the sun during the day over a relatively long wavelength at night. As a result, the temperature inside the greenhouse is higher than the temperature outside. In the same way, some gases in the atmosphere increase the temperature of the air by absorbing the re-radiated heat from the sun's heated surface. This process is collectively known as the greenhouse effect. Greenhouse gases are caused by gases such as water vapour, methane, carbon dioxide, nitrous oxide, etc. These gases are called greenhouse gases. The reasons for the increase of greenhouse gases are: The burning of oil, gas and coal produces carbon dioxide and nitrous oxide. Methane is released into the atmosphere because of the decomposition of various plants, animals and living things. This methane gas is 30 times stronger than carbon dioxide as a greenhouse gas.

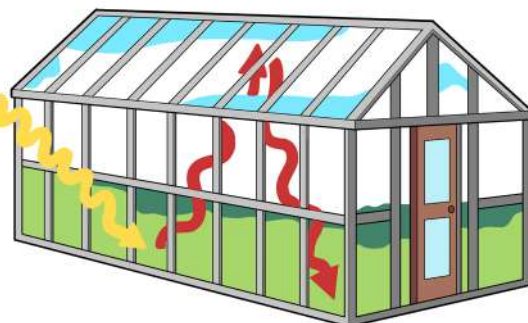
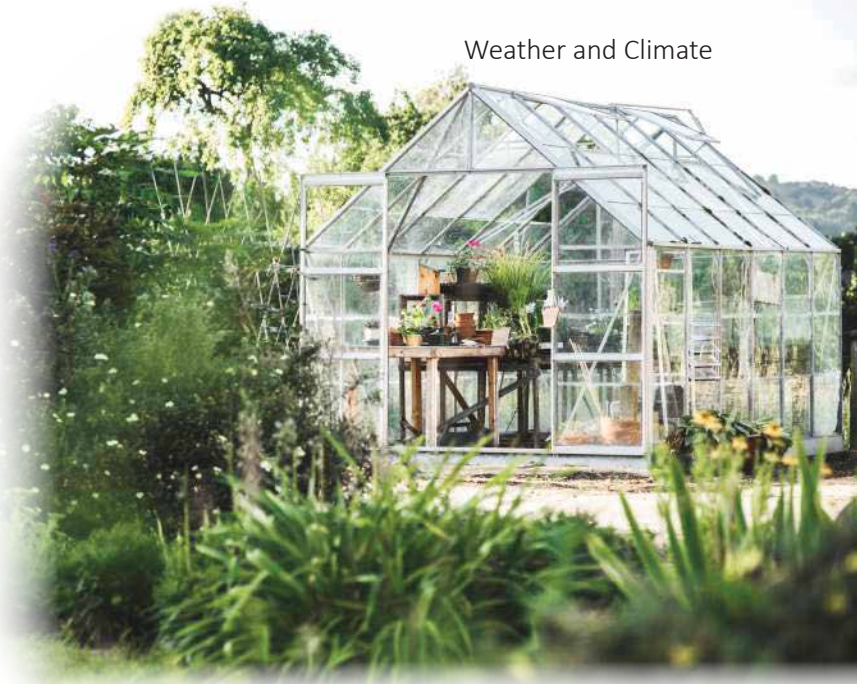

As cattle rearing increases, the amount of methane gas also increases. Cattle such as cows, goats, sheep, etc. release large amounts of methane gas into the air due to their digestion of food.

When nitrogenous fertilizers are used in agricultural lands, nitrous oxide is produced and spread in the

air. This gas is at least 10 times more harmful than carbon dioxide and can cause about 300 times more damage.

Deforestation and felling trees are reducing the number of trees to absorb carbon dioxide from the air. As a result, carbon dioxide in the air is increasing. Fluorinated gas is emitted from some appliances and products (such as, refrigerator, air conditioner, foam, aerosol etc.). The greenhouse effect of this gas is about 23,000 times greater than carbon dioxide.

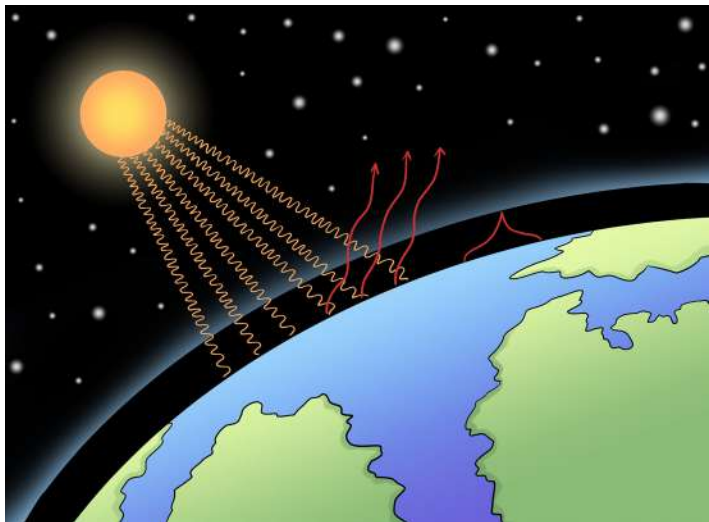

Image: Green House Effect

When the amount of these gases increases, the greenhouse effect in the Earth's atmosphere also increases. As the temperature of the atmosphere rises due to the greenhouse effect, the ice at the two poles of the earth (north and south poles) is melting and raising the sea level. Even many types of disease-causing germs are becoming active. It can increase the outbreak of various diseases.

Acid Rain

If acid or acidic elements are mixed with rainwater, it can be called acid rain. In this case, sulfuric acid or nitric acid mixed with rainwater falls to the ground. Even acidic substances in solid or liquid state can be mixed with snow, fog, hailstones and dust particles. Now the question is how did this acid get into rainwater, fog, snow etc.? Sulphur dioxide and nitrogen oxide are emitted from various man-made and natural sources. Reacting with water vapour, oxygen and other chemicals present in the air, these gases form sulfuric and nitric acids. Then they mix with water and other substances and fall to the earth's surface. A small portion of sulphur dioxide and nitrogen oxide comes from natural sources (such as, volcanoes) but most portions come from different man-made sources. The sources are —

- » Burning of fossil fuels (such as, oil, gas or coal) for power generation. 2/3 part sulphur dioxide and 1/4 part nitrogen oxide of the air are emitted from the power generator.
- » Various vehicles and heavy equipment.

Manufacturers of various products, oil refineries and other factories.

The air can carry polluting gases emitted from these sources and other particles to a great distance and may cause acid rain there. As a result, the polluting countries as well as other distant countries may experience acid rain, which can cause damage to the area. Some of the damages caused by acid rain are:

- » Makes life difficult for fish and other aquatic creatures.
- » Damages different parts of the plant.
- » Destroys the quality (which is required for plants and other micro-organisms living in the soil) of soil.
- » Damages equipment made of various metals, other installations and even buildings. Acidic rainwater reacts with metals and concrete and decays them.

Ozone layer depletion

From the lower part of the atmosphere to the second layer (stratosphere), there is a part of ozone gas which is known as ozone layer. This layer absorbs the ultraviolet rays coming from the sun and helps the earth's various living things to survive. But this layer is depleting (decreasing) due to the presence of some polluting elements. As a result, harmful ultraviolet rays enter the earth and cause damage to the living world. Polluting elements responsible for ozone layer depletion are chlorofluorocarbon, carbon tetrachloride, hydrochlorofluorocarbon and so on. Ozone layer depletion can have the following harmful effects:

- » **Impact on human health:** As a result of depletion of the ozone layer, humans come to direct contact with harmful ultraviolet rays. As a result, they suffer from various physical problems such as skin diseases, cancer, reddening of the skin due to sun exposure, cataracts in the eyes, premature aging, poor immune system, etc.
- » **Impact on animals:** Direct contact with ultraviolet rays can cause cancer of the eyes and skin of animals.
- » **Impact on plants:** Strong ultraviolet rays can slow down plant growth, disrupt food production of plants (it is called photosynthesis) and even disrupt flowering. As a result, the plants of the forest have to bear this harmful effect.
- » **Impact on aquatic and marine life:** Tiny plants and animals (known as plankton) face severe damage in the presence of ultraviolet rays. This plankton is a source of food for fish and other aquatic organisms. If these are destroyed, aquatic life will also be damaged.



Man-made impacts on climate

Various human activities are having a harmful effect on the climate of the whole world. This damage is mainly caused by greenhouse gas emissions, depletion of the ozone layer, tiny particles (called aerosols) floating in the air, and deforestation by cutting trees. As a result, the temperature and the amount of rainfall are changing in different parts of the world. The following are some of the incidents that may happen because of climate change:

- » The polar ice caps are melting, and the sea level is rising.
- » The number of heavy rains and strong storms is increasing. This is causing floods in some places and decreasing water quality. Again, the chances of getting water in some places are decreasing.
- » The Mediterranean region, the southern and central regions of Europe are experiencing regular hot weather, droughts and forest fires.
- » Other developing and underdeveloped countries, including Bangladesh, are facing various natural disasters (such as storm, heavy rain, flood, tidal surge, droughts, etc.) because of climate change.
- » Many plants and animals are at risk of extinction because they cannot adjust themselves with climate change.

Exercise



1. Is the air pressure high or low on high hills?
2. What activities of people or factories around you are increasing the greenhouse effect in the atmosphere? Notice it?



Chapter 6

Earth and Universe

Chapter 6

Earth and Universe

At the end of this chapter, students will be able to know the following:

- ✓ The earth and the universe
- ✓ The Big Bang and the expansion of the universe
- ✓ Galaxies and stars: Structure and substructure
- ✓ Constellations: Observing the Orion and the Ursa Major
- ✓ The prevailing superstition about the space: Astrology

Creation of the universe



You all know that our earth is a planet. Eight such planets are orbiting the Sun. The size of the Sun is huge but it looks small because it is far from the earth. You also know that light and heat come out from the Sun because it is a star.

If you look at the night sky, you will see numerous stars like the Sun. They are far away, so you will see them twinkling and not shining like the Sun.

Image: Our solar system

Formation of the universe

You must be curious to know how big this universe is. The amazing thing is that the universe is constantly expanding and the people of the world will never be able to see the whole of it. What they see is so large that according to scientists it would take a hundred billion (ten thousand crore) years for light to travel from one end of universe to the other! There are countless stars in this universe but they are not equally distributed. They are in the middle of huge galaxies. A galaxy is a collection of countless stars. Due to the gravitational force, the stars are stuck inside the galaxy. These galaxies are scattered throughout the universe, and one galaxy is farther away from another. If we imagine the universe as a very large ocean, the galaxies would be like tiny islands scattered far away. It is estimated that there are about one trillion (one lac crore) galaxies in the visible universe, each of which has about one billion (one hundred crore) stars!

Our Galaxy

You all know, the Sun is a star. So, it is in the middle of a galaxy. That is our galaxy, and our galaxy is called the Milky Way. Most galaxies are shaped like a plate. The sun is at the edge (corner) of this galaxy. So, when we look at the night sky, we see countless stars in the galaxy like white smoke. Those of you who have not yet seen this galaxy in the night sky will see this galaxy at place away from the city when there is no moon in the night sky.

We can't see our galaxy because we're inside it. We can only imagine what it looks like. But if we look at the sky in autumn or winter, we see our nearest galaxy, Andromeda. If we look



Our galaxy is called a Milky Way

Science

deeper into the space with a telescope, we will see more galaxies. It would seem that there is no end to the galaxy.



Our nearest galaxy is Andromeda



Artist's rendition of the sun's position in the galaxy

Creation of the universe

When scientists saw only galaxies and galaxies in the universe, they began to study them. They were surprised to discover that the galaxies were moving away from one another. It means at one time they must have been closer!

Scientists have researched out that 14 billion (one thousand four hundred crore) years ago, the whole universe was at one point. That point has expanded into the present cosmos after an incredible explosion. The name of that explosion is Big Bang. The expansion that began 14 billion years ago is still going on and will continue.



If we look deeper into the space with a telescope, we will see galaxies and galaxies, and about one billion stars in each galaxy

The Big Bang has a lot of details, which you will gradually learn when you grow up. Know it for now that after the Big Bang, there was only energy in the universe at first and gradually different kinds of particles started to form there. The simplest atom, called hydrogen, was formed first.

You will be surprised to hear that at that time the whole universe was in complete darkness! The universe became enlightened when stars began to be born there.



Birth of Stars

The stars are not living creatures, but we use the two words- birth and death for the stars. As the stars are really born, they have a very eventful life, and then at some point the stars die.

You have been told a little earlier that after the Big Bang, there was first energy in the cosmos and then hydrogen was created. This hydrogen unites somewhere and takes the form of a gas lump, called a nebula. If there is enough gas in that nebula, its temperature increases when it starts to compress due to the gravitational force. The temperature can rise so much that the inner hydrogen then reacts with each other in a process called nuclear fusion and gives birth to a lot of energy. Light begins to come out of that star, and we say the star has been

born! This is exactly how our sun was born five billion (five hundred crore) years ago. For another five billion years, the sun will shine like this. Then at a time when it will run out of hydrogen fuel, it will swell and fade (the form is called Red Giant) and will die. This ending of a lightless, dull star is called a White Dwarf. This is the life of most of the stars in the cosmos.



Image of supernova explosion as obtained from NASA

Black Hole:

If a star is born much larger than the Sun was in the beginning, the life of that star is much more amazing. The life of a star is strange. The larger the mass of the star, the faster it runs out of its fuel. If a star is very large, it runs out of fuel and makes many kinds of elements. At one point it causes an incredible explosion and ends up its life.

That explosion is called the Super Nova explosion and the light of the Super Nova explosion lightens the whole universe!

The outer part of the star shatters and flows away because of the Super Nova explosion. But the inner part shrinks because of the strong attraction of the gravitational force and turns into a black hole at some point.

It is called Black Hole because even the light cannot come out from there because of the internal attraction of the Black Hole.

The mystery of the black hole is even more astonishing. You will learn more about it when you grow up.

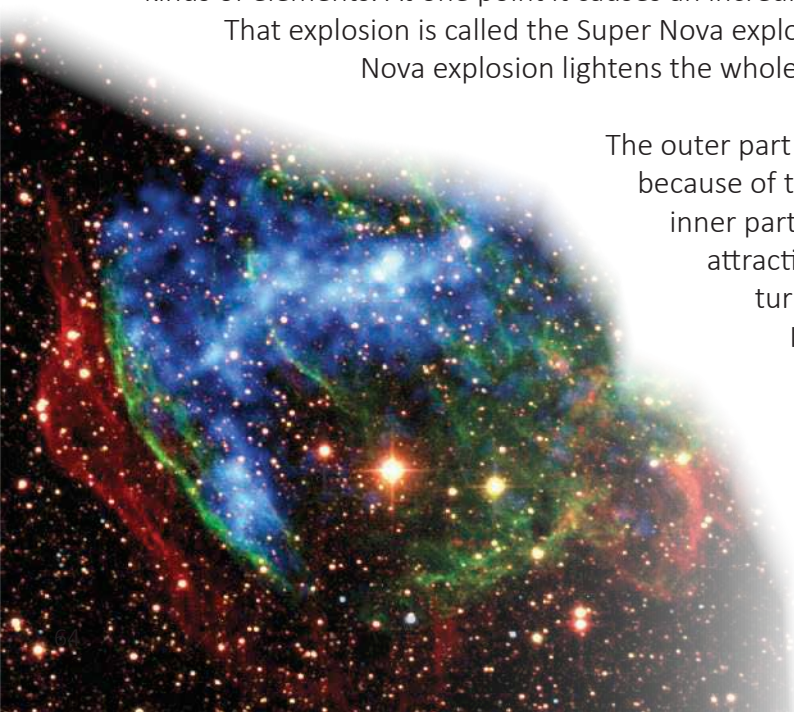

DRACO

M82

M81

 σ^2 ρ π^1 π^2

Constellation

If you look at the dark night sky, you will see countless stars. Some of them are flashing, some are twinkling. Not only that, you will also find a variety of colours in them. If you have the imagination, you can surely imagine certain pictures with those stars! From the ancient times, such imaginary pictures have set off many mythologies. Some such pictures are given below



Images of the ancient human imagination by looking at the arrangement of the stars:

- Upper left is 'Orion'
- Upper right is 'Ursa Major' or 'Big Dipper'
- 'Scorpio' in the picture below

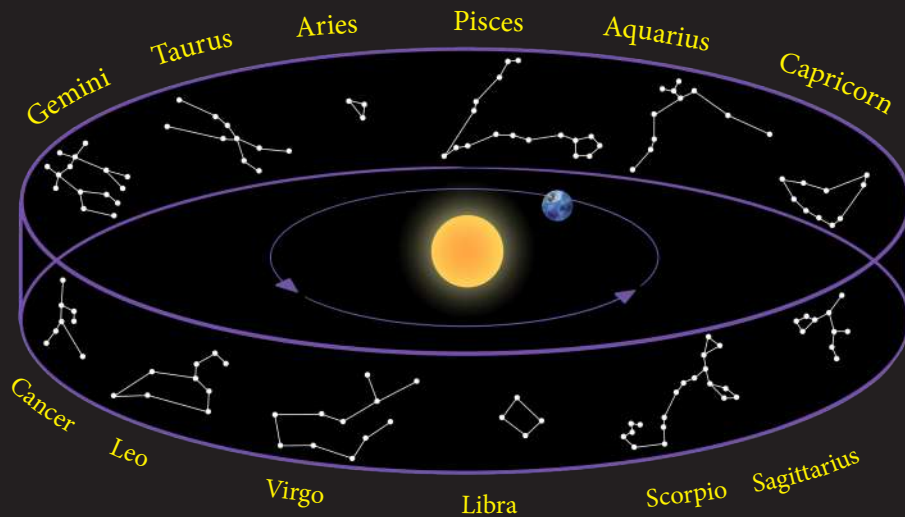

As the constellations are far away from our solar system, the time and place of their appearance in the sky changes. However, their size does not change. It is difficult to find a star in the sky. But when a few stars unite and form a particular shape, it is quite easy to find out it. So, to create a map of the stars in the sky, the sky has been divided into twelve parts using constellations. They have been given such names by imagining a picture with constellations. (You are shown such examples in the pictures) Astronomers use this division of the sky.

You must be surprised to know that our Bengali months have been created in connection with the rise of these constellations. So many nations of the world do not have their own calendars, but we have. Not only that, our ancient astronomers made this calendar, matching it with the constellations of the sky. You can be proud of that!

Astrology

This time you will know how a subject of science is used for superstition. You must have heard the names of the constellations of the picture. These constellations are used in fortune telling. These are also used to determine good times and bad times.

In astrology, one's zodiac sign is determined by the constellation rising at the time of one's birth. Then, the fate of different people is determined by using the location of the constellation. The fate of 8 billion (eight hundred crore) people of the world are divided into only twelve parts! Can this be credible? Sadly, many important newspapers in the country use this zodiac sign to describe fortune telling. All of them should declare at the beginning that there is no scientific basis for determining one's fate in this way.

Observations of constellations



Getting acquainted with our constellations is a wonderful experience. When a person leaves his country and goes abroad, everything is unfamiliar to him. If he looks at the sky, he can get a kind of pleasure by seeing his familiar constellations. Here are two constellations for you, you can find more constellations if you wish.

Big Dipper

The earth rotates on its axis. We see all our planets, stars, sun and moon revolving in opposite directions centring the earth. Only one star is never revolving and fixed to the earth. That is the Pole Star or Polar Star. The pole stars are fixed in a certain place because the earth's axis is along the north-south and the pole stars are just north of the earth! It's easy to find out. If you look at the north of the night sky, you will see seven stars arranged like a question mark (It is called Big Dipper in English). Imagine a straight line with two stars above it, and if you go a little farther, it will touch the pole star. The Big Dipper revolves around the pole star like the hands of a clock. So, where in the sky the Big Dipper is and whether it is straight or upside down depends on what time of the year and what time of the night you see it!





Orion

Orion constellations can be seen very clearly in the eastern sky in the evening during winter. Its structure is so impressive that it is very easy to identify it. You have already been shown that it is imagined as a warrior with a sword in the hand. The star in the middle of the sword hanging under the warrior's belt is a nebula. And at its centre, there is a black hole 200 times heavier than the sun. Once you see this star with your own eyes, you can proudly say to everyone, "I have seen a black hole with my own eyes."



Excercise



1. If a point refers to a star, which image will most accurately describe our universe?
2. How many years after the Big Bang was the Sun born?

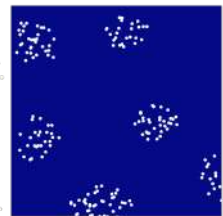
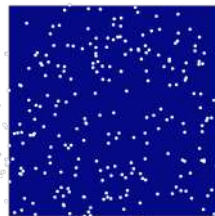



Chapter 7

Motion

Chapter 7

Motion

At the end of this chapter, students will be able to know the following:

- ☑ Different types of Motion
- ☑ Measurement of velocity
- ☑ Acceleration

Linear Motion

You may know from the newspaper or television news that occasionally a spaceship has travelled from Earth to a planet far away. Some planets are so far away that it takes several years for a spacecraft to reach there. Many of you may think that spacecraft has to carry huge amounts of fuel to travel that far. Indeed, for that reason, the size of these spacecrafts is also huge! The engines of the spacecraft burn this huge amount of fuel and take the spacecraft to distant planets.

Those of you who do not know yet will surely be surprised to hear that spacecrafts do not consume any fuel to get to this distant planet. A characteristic of motion is that if something moves at an equal velocity in a straight line, it will continue to move that way; you don't have to do anything to keep it going. If the motion of the object needs to be increased or decreased or the direction changed, only then you will need a little bit of fuel to apply force on it. We'll find out later what force is referred to in science. For the time being, by the term 'to apply force' we will understand the common meaning — that is, to push, to pull, or to attract something. Since you don't see that happening

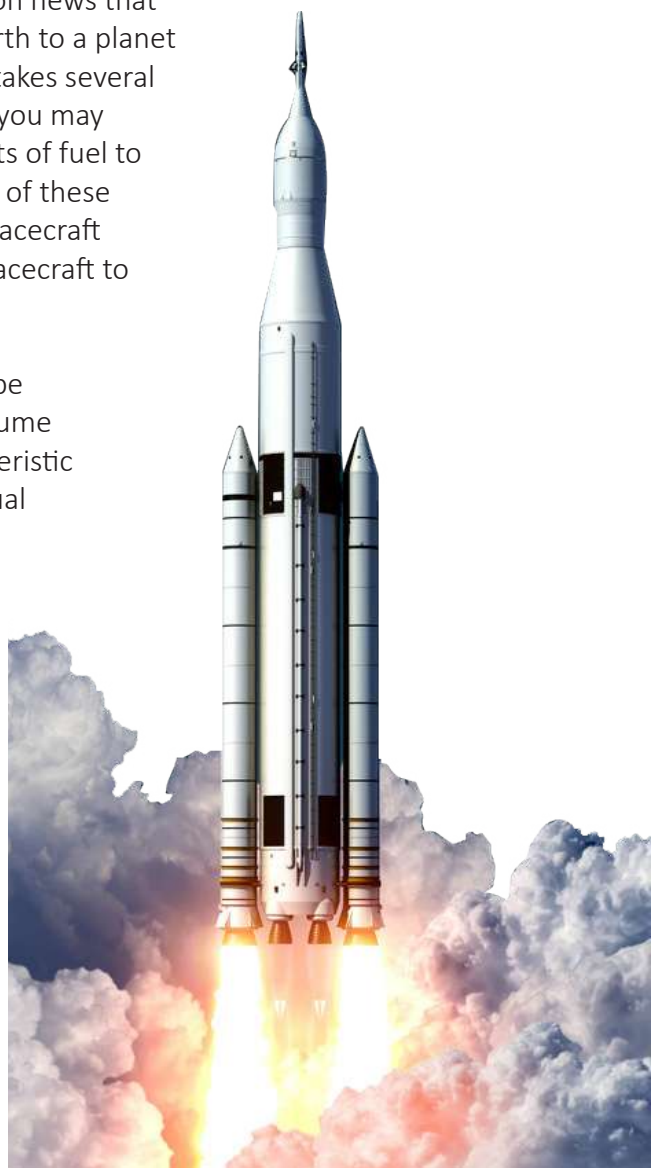
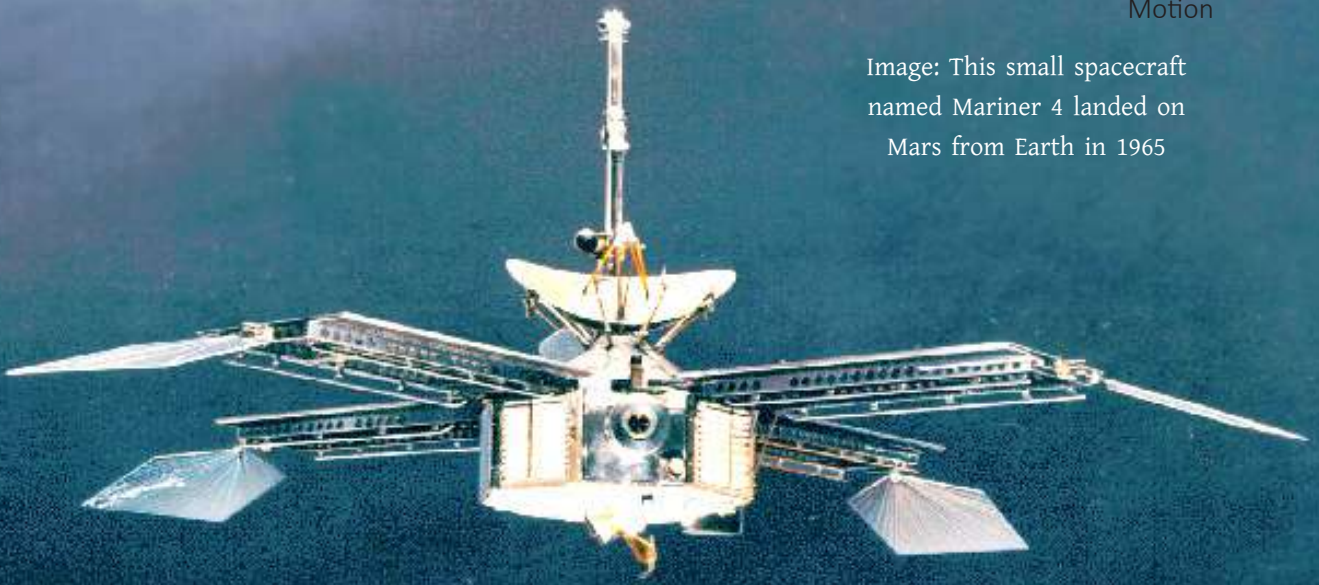

Image: This small spacecraft named Mariner 4 landed on Mars from Earth in 1965



in your daily life, everyone must be wondering how this is possible! Many of you have rolled a marble or a toy car on the floor. You must have noticed that the car does not run at all with the velocity of a straight line for eternity. The marble or the toy car stops sooner or later. The reason is friction with the floor or friction of the wind. If you could really reduce the force of friction, you would be surprised to see that the marble or the toy car is not stopping, rather it is running and running. Those of you who ride bicycles must have noticed that after starting the bicycle, you have to increase the velocity of the bicycle by pressing the pedals with a little effort first. Once the velocity of the bicycle reaches the target, the bicycle continues to move at the same velocity even if the pedal is not pressed. Then you can ride the bicycle, pressing the pedals from time to time to retain the reduced velocity due to friction. You may even talk to people who drive cars, buses or trucks. You will know that when they start to increase the velocity of the vehicle from the initial steady state, the engine consumes a lot of petrol, diesel or gas. When the velocity of a car, truck or bus reaches its target, they consume very little amount of petrol, diesel or gas to maintain that. So, you have come to know a very important feature of velocity and that is:

If something goes in a straight line with an equal velocity, it will continue to go that way; force is to be applied in order to increase or decrease the velocity, or to change the direction.

Curve motion

If someone tells you to roll a marble on the floor in such a way that it follows a curved path rather than goes straight, then you will see that it is not possible at all. No matter how hard you try, the marble will go straight. You must have got the reason by now

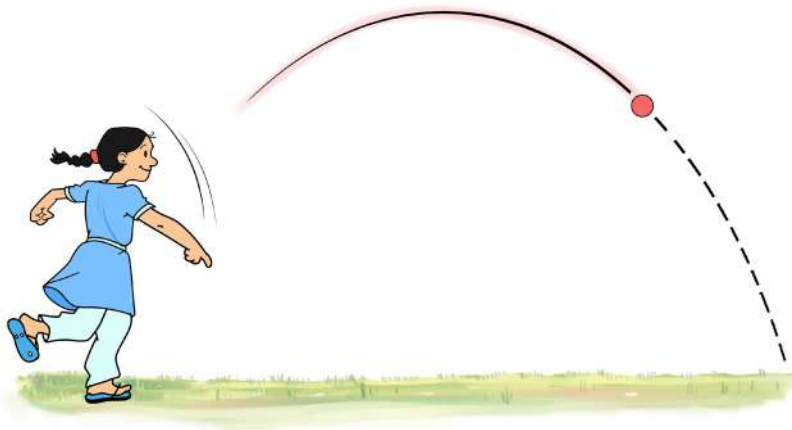

Image: When something is thrown upward, it falls down in a curved way due to the gravitational force.

that you have to apply force on the marble to send it in a curved path. However, after the marble is rolled on the empty floor, no force can be applied on it. However, there is a very simple way to move an object in a non-linear motion. If you throw something in the way it is shown in the picture, you will see that it is following a curved path instead of going straight. That means, you have made it possible to create a curve motion in it. By now you must have understood the reason. When you throw something, the gravitational force on it works downwards and that's why the object goes in a curved path instead of going straight.

Circular Motion

Another example of non-linear motion is circular motion. You can tie a small stone with a string and roll it over your head. This is an excellent example of circular motion. The stone is changing the direction every moment to rotate. That means, surely you are to apply force on it. Where is that force coming from? By tying the stone with a string, you yourself are pulling the stone and applying force on it towards the centre. Therefore the stone is circling around you. If you suddenly leave the string, the stone will go straight. The stone will not go circular way as there will be no more force on it.

Can you give any more example of such rotational motion? All of you have seen one example in the moon in the sky. We all see the moon in the sky slowly growing from a narrow form to a full moon. Then again, it slowly becomes narrower and disappears completely during the New Moon. This happens once every 29 days as it takes 29 days for the moon to orbit around the earth once! Whether the moon looks narrower or a full moon depends on which side of the earth it is in, compared to the sun. This rotational motion of the moon around the earth continues because the earth pulls the moon towards itself with its gravitational force— just like you tied the piece of stone with

a string and pulled it towards you! In the same way, the earth revolves around the sun because of its attraction to the sun. Again, the sun continues to revolve around its centre for the attraction of a huge black hole in the centre of our galaxy! If you remain aware all the time you will find many examples of rotational motion around us. From now on, whenever you see this kind of motion, you will observe it carefully. There are many interesting things hidden in it.

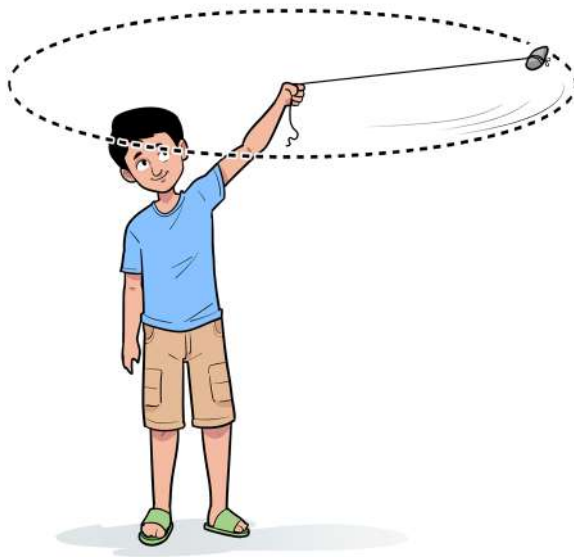

Image: To rotate a small stone with a string, it has to be pulled and held towards the centre.

Periodic Motion

So far, we have talked about linear motion, curve motion and circular motion. In addition to these three motions in our daily life, we see another special kind of motion and that is Periodic Motion. This motion is easily distinguished. When you sway in the swing, that is an example of periodic motion. Water hyacinth floating in the pond starting to go up and down due to a wave is another example of periodic motion. Again, if we add a mass to a spring and pull it down and let it go, it goes up and down. That is also an example of periodic motion. That is, when the motion of a moving object repeats itself because of the regular change of direction of the force applied to the object, it is called periodic motion. The characteristic of this kind of motion is that it has an oscillation period and

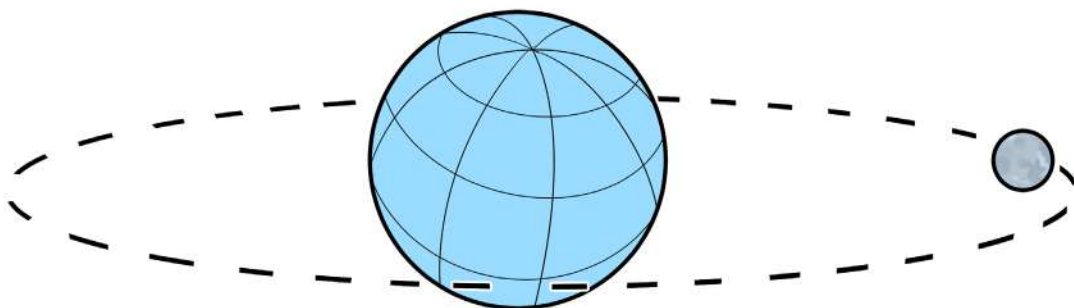

Image: The moon can revolve around the earth because the gravitational force of the earth is holding the moon.

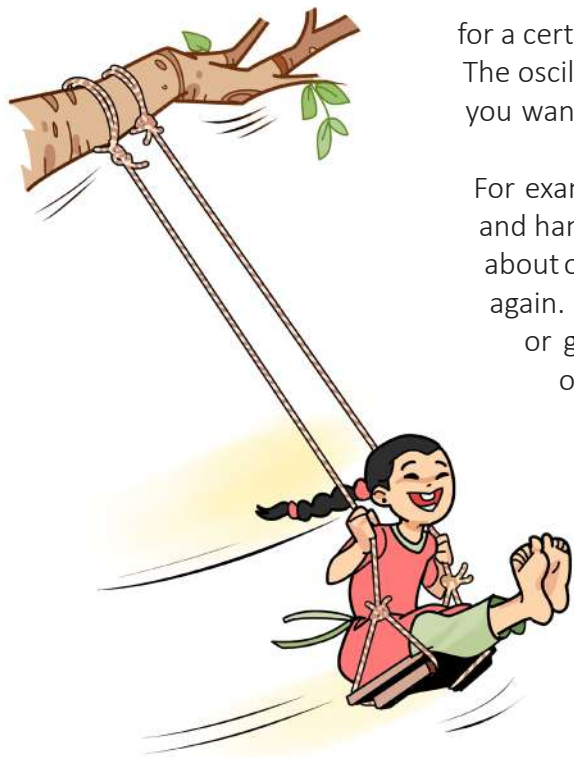

Image: Swaying in the swing is an example of periodic motion

for a certain situation that oscillation period is always fixed. The oscillation period cannot be increased or decreased. If you want to change it, you have to change that situation.

For example, if you tie a small stone with a 30 cm string and hang it, you will see that it will go from right to left in about one second and will come back to the previous place again. No matter how hard you try to shake it strongly or gently, it will always take one second to oscillate once fully. If you change the length of the string, only then you can change the oscillation period.

You will learn more about periodic motion when you go to higher classes. For now, just remember the important part of it. As in periodic motion, the motion of an object changes, it means that the direction of the force which is moving the object also changes.

Can you analyse the above examples and guess what force is working on the object and how it is changing the direction?

Measurement of Velocity

We measure the velocity of an object from how far it has travelled in a given time. If a car travels a distance of 36 kilometres in an hour, we can express its velocity in v, meter in m and second in s.

$$v = \frac{36 \times 1000}{60 \times 60} \frac{\text{metre}}{\text{second}} = 10 \text{ metre per second}$$

The table beside shows the possible speed of different vehicles per hour. Let me remind you of one thing, we cannot increase the velocity of an object indefinitely even if we wish. An object has a maximum velocity; it is not possible to increase the velocity beyond that. That is the velocity of light. The velocity of light is three lakh kilometres per second!

Acceleration

You have already known that if force is not applied to a moving object, the object will

continue to move with an equal velocity in a straight line. In other words, we can say, we have to apply force to change the velocity of an object. You have also known that the velocity of an object can be changed in two ways- by increasing or decreasing the velocity of the object if it is moving in a straight line and if the direction of a moving object changes, its velocity also changes.

Vehicle	Velocity (km/hour)
Cycle	20
Car	100
Plane	800
Rocket	30,000

We need to apply force to change the velocity of an object. So, to understand force well, you have to understand the change of velocity very well. That is why there is a different name for the change of velocity, that is acceleration. Whenever velocity changes, we say 'acceleration' has happened. We will now find out how to measure the acceleration of an object moving in a straight line. In the upper classes, we will know the acceleration when the direction changes or the acceleration of an object moving in a curved line.

We have measured the velocity from how much distance is covered in how much time. In the same way, we can find out the acceleration from how much the velocity has changed in how much time. That means,

$$\text{Acceleration} = \frac{\text{Final velocity} - \text{Initial velocity}}{\text{Time spent}}$$

If the acceleration is negative, then the speed is actually decreasing. We often use the word deceleration to mean decreasing.

Exercise



1. Can you give examples of linear, curve, rotational, circular and periodic motions outside of the examples given in the book?
2. If the radius of the Earth is 6000 km, then how much time will it take to travel around the entire Earth by plane? How much by rocket?



Chapter 8

Force and Energy

Bangladeshi cricketer Sanjida Islam
in the image

Chapter 8

Force and Energy

At the end of this chapter, students will be able to know the following:

- ☑ Force
- ☑ Friction Force
- ☑ Ways of increasing and reducing Friction Force
- ☑ Simple Machines

We use the word 'force' in many ways in our daily conversations. But in science, the word force has a specific meaning! Truly speaking, you have already known what is meant by force in science:

Force is something that can change the motion of an object, that is, can create acceleration in an object.

When you will read Newton's world-famous formulas in the higher classes, you will see how force is explained with the help of acceleration!

In addition to changing the motion of an object, force can also do another task. It can often change or distort the shape of an object. By applying force, you can bend a rod, stretch a spring or twist a wire. In our daily lives we use force every moment. Sometimes we use force directly, sometimes we use force with a device, and sometimes we protect ourselves from unnecessary force.

To know about force, we have to do various experiments with force and we need to use the right amount of force in these regards. Do you know that nature has a system for us to use the perfect amount of force? That is the gravitational force. This particular gravitational force is always applicable if you throw something down from above and at that time the object keeps falling down at certain acceleration. We can also use this force by letting something roll on a

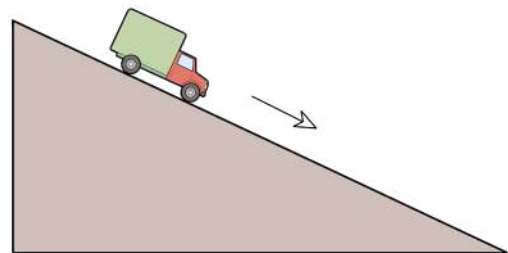

Image: By increasing or decreasing the angle of a slope, we can apply more or less force on an object.



Image: The attraction of magnets is an example of force.

certainly seen a piece of paper being drawn with that comb with a kind of force. Some types of forces in nature invisible in our daily life are also there. You will be able to know about them when you grow up.

Friction force

You have already known that if the velocity of an object were not reduced by friction, it would continue moving indefinitely. That is why many of you may think that the matter of friction is also a kind of harmful force. But that is not entirely true. In some cases of our lives, we try to reduce the frictional force and again in some cases we try to increase the frictional force. Before looking at those things, let's understand in one word where the frictional force comes from.

If you place a piece of wood on a very smooth table and push it from left to right, then a counter force will work from right to left on top of that piece, which will reduce the force applied by you. If you push the piece of wood from right to left, then the piece of wood will work from left to right and will reduce the force applied by you. This means that whichever way you use the force, it will always work in the opposite direction and reduce the force. This is called the frictional force.

To understand why the frictional force works in this way, if you magnify the part of the table where the piece of wood touches the table with a microscope, you can see that the piece of wood or the part of the table that you think is smooth is not really smooth. Those parts are unsmooth and there are numerous grooves in those parts. So, when a grooved unsmooth part sits on another part of the same type, then one groove goes into the other groove. When pushed, these tiny parts

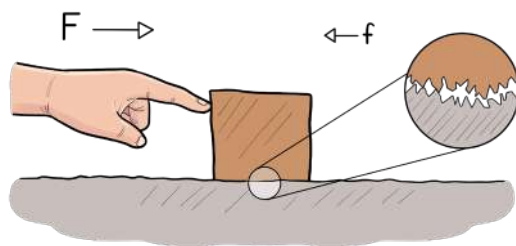

Image: Even a smooth surface looks unsmooth when we look at it with a microscope.

have to be smashed. Then, very naturally we encounter a kind of obstacle, which we call the frictional force. If something heavy is pressed against the wood, then the amount of frictional force increases. This is because if more pressure is applied, the upper unsmooth parts and grooves go deeper into the lower unsmooth parts and grooves and increase the frictional force.

Reducing the friction

Sometimes, we want to reduce the frictional force. Heat is generated due to friction. In winter we keep our hands warm by rubbing. Heat is generated due to friction in the cylinder of the car- heat generation means loss of energy. Moreover, if the heat cannot be removed, the engine of the car gets heated. For that reason, friction is to be reduced there. Cars or aircraft are always built in such a way that there is less friction of air. Attempts are also made to reduce friction with water on ships or submarines at sea. Here are some ways to reduce friction:

1. Friction is less on smooth surfaces. So, attempts are made to smooth the surface on which friction occurs.
2. The friction can be reduced by using oil, mobil or grease in the two surfaces under friction.
3. Friction can be reduced by using wheels because wheels touch a small place.
4. Friction can be reduced by using ball bearings on the rotating wheel.



Image: Friction can be greatly reduced using ball bearings.

Increasing the friction

We often want to increase friction. For example, we could not walk without friction, if we tried to walk, we would slip. We want to increase the friction of the road with the wheels of cars so that cars can firmly grasp the road and move faster. Using air friction, we can safely land with a parachute. Here are some ways to increase friction:

1. To make the two surfaces under friction more unsmooth.
2. To press hard the two surfaces that are under friction.
3. To make grooves in the middle of the surfaces under friction. It is done on the sole of shoes or on the wheel of cars.
4. To make arrangements for keeping stable the two surfaces under friction. Because the friction is more when the two

surfaces under friction are stable.



Image: A parachute can come down using friction of air.

Simple Machines

Do you know that the building code was officially passed in Bangladesh in 2015? According to the Code, it is mandatory to place a ramp at the entrance of all buildings, so that anyone with a wheelchair can enter the building on his/her own without the help of others. A ramp is a simple machine. There is a kind of 'mechanical advantage' of using it.

It is not easy to lift up a heavy object or a wheelchair. But if a ramp is used, a wheelchair or other heavy objects can be easily lifted up- or we can say that a kind of mechanical advantage is availed.

By simple machines we mean such machines which are very simple to make and which can be used to increase the applied force or to change the direction of applied force. The advantage of using a simple machine is called mechanical advantage.

We can divide the simple machines around us into 6 types. They are:

1. Lever

You must have seen the see-saw made of wooden planks for children in the park. It is placed slightly raised in the middle to move freely on both sides. Then two children of equal weight on each side can ride it and move it up and down as they wish. If a child sits on one end but an adult weighing much more than the child on the other end, then the child can no longer move it up and down.

The middle point on which a see-saw is placed is called fulcrum. If the adult can be brought closer to the fulcrum by keeping the child in its place, then the child can easily lift an adult who is much heavier than it. Because a type of mechanical

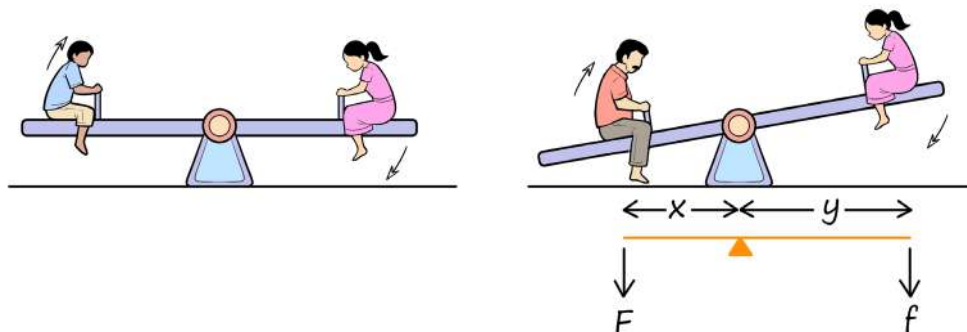

Image: On the left are two children of equal weight on each side of the See-Saw. In the right picture, a child can lift an adult using the mechanical advantage as the adult is near the fulcrum.

advantage of a lever can be enjoyed from the position of the fulcrum.

The mechanical advantage of a lever can be determined with a simple formula. In the way shown in the picture, if the distances of the two sides from the fulcrum are x and y , then the greater the y distance from x , the greater the F force can be handled by applying the smaller f force.

That is

$$x/y = f/F$$

Mechanical Advantage:

$$F/f = y/x$$

Emphasizing the importance of this matter of mechanical advantage of the lever, the scientist Archimedes said, 'If you give me a place to stand in the space, I can move the world.'

2. Pulley

You have noticed the hoisting of the national flag at your school. The teacher pulls a rope down and the flag goes up. This is happening because the rope tied to the flag is twisted through a pulley. The picture beside shows you the use of two pulleys. In the first picture there is a 10 kg weight on one side of the pulley. Someone from the other side is pulling up the weight with a rope. Here the weight is going up when the rope is being pulled down. Here we are changing the direction of applying force and lifting the weight upwards, applying force towards the bottom — this can be a kind of mechanical advantage.

In the second picture, the weight is hanging from the pulley, but it can move freely as it is not attached anywhere. Here we have to pull up the rope to lift up the weight. The weight will rise to half the distance the rope has been pulled up. That's why we will get a mechanical advantage- we can lift up the weight by using half force.

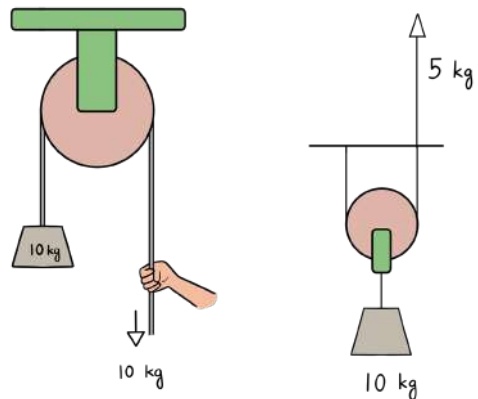

Image: In the picture on the left, the direction of applying force has been changed. In the picture on the right, the heavier object is being pulled up with less force.

3. Ramp

You have already been told about a simple machine called a ramp to enter a building in a wheelchair at the beginning of this chapter. You yourself must have noticed that climbing a steep slope is difficult enough. But if the slope of the floor is much lower, it is relatively easy to climb it. So, to find a mechanical advantage, we have to determine the comparison of how high we can go by crossing what distance.



Image: One can easily climb up in a wheelchair using a ramp.

$$\text{Mechanical Advantage} = \frac{\text{Mechanical Advantage}}{\text{Covered height}}$$

The minimum mechanical advantage for lifting a wheelchair is 12.

4. Wheel and Axis

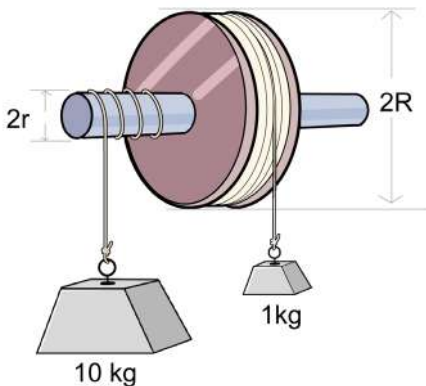

Image: It is possible to lift up a heavy weight hanging on a narrow axis with a low weight hanging on a big wheel.

You all have seen the wheel and everyone knows that the wheel rotates on one axis. If the radius of a wheel is greater and the radius of the axis is smaller than that, then this axis-wheel combination can be used as a simple machine. Imagine a big wheel and its two axles are wound with rope in such a way that the axle starts to rotate when the big wheel is moved by pulling the rope. Keep winding another rope there. Now if you tie a heavy weight to the axles, you will see that you can easily pull the big wheel by pulling the rope. If the radius of the big wheel is ten times the radius of the axles, then you can pull a weight of ten kilograms using the force equal to one kilogram. That is, the mechanical advantage is:

$$\text{Mechanical Advantage} = \frac{\text{radius of the big wheel}}{\text{radius of the axle}}$$

5. Wedge

You must have seen an axe. Have you ever noticed the blade of the axe? If you do, you will see that the head of the axe blade is narrow and gradually it has become wider. Due to the special shape of the axe blade, there is a mechanical advantage to using it. While cutting wood, you hit with an axe, the axe blade penetrates into the wood with more force than the force you really apply on it. If the length of the blade is L and its thickness is t , then the mechanical advantage is:

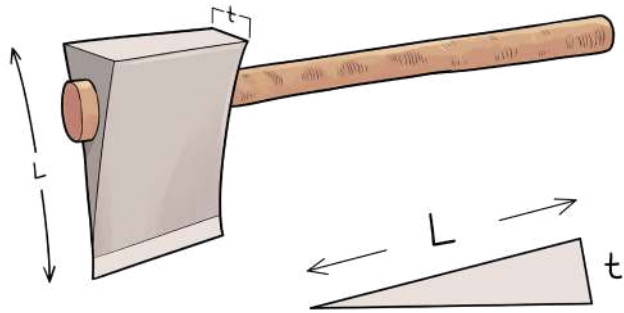

Image: An axe blade is an example of wedge.

$$\text{Mechanical Advantage} = \frac{\text{length of the blade}}{\text{thickness of the blade}} = \frac{L}{t}$$

6. Screw

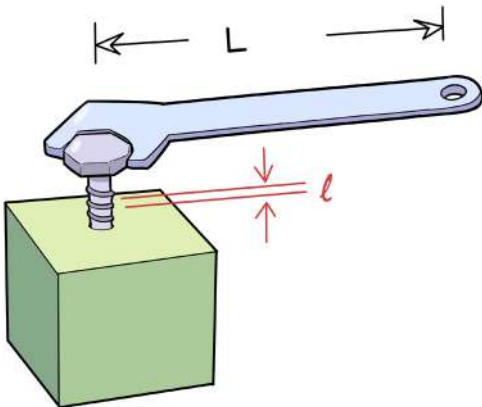

Image: The larger the length of a wrench, the greater the mechanical advantage.

You have seen or used screws. A screw has grooves in it and it can be penetrated into a solid body by turning it. The screw can be penetrated into a hole by turning it with a screwdriver on its neck. It would be easier to penetrate it into the hole if a long rod had been attached to the screwdriver's neck. That is, in order to get the mechanical advantage here, we have to put a long bar and turn it around- the way it is done with the wrench. You may have noticed that the wrench is lengthened by inserting a pipe while taking out a bolt from the wheel of a car. The mechanical advantage here depends on the length of the wrench (L) and the distance between the two grooves (l).

$$\text{Mechanical Advantage} = \frac{\text{length of the wrench}}{\text{distance between the two grooves}} = \frac{L}{l}$$

Exercise

?

Pictures of different types of machines are given below. Can you tell which kind of simple machine they are?



Energy

We are all familiar with the word energy. When the power of something is too much, we call it strong or energetic. Do you know that in science, the words energy and force have definite meanings? They mean completely different things.

In the meantime, you have come to know what it meant by force. Something that can change the motion is the force. Something that 'can do any kind of work' is energy. Here work refers to move anything by applying force. You will be able to know the details about it in the upper classes.

Kinetic Energy

There are different kinds of energy in the world. For example, heat is a kind of energy, light is a kind of energy, electricity is a kind of energy, sound is a kind of energy. But our most familiar energy is kinetic energy. Whenever we make any object dynamic, a kind of energy is created inside it; that energy is called kinetic energy. You must have felt it in many ways- nothing happens if you put a hammer on a brick. But if you hit the hammer on the brick with great speed, the brick will be crushed. The reason is that energy is created in the hammer because of the kinetic energy. If the mass of an object is m and if it travels with velocity v , then its kinetic energy will be:

$$\text{Kinetic Energy} = \frac{1}{2}m(v \times v)$$

If a car travels at a velocity of 40 km per hour, it will have a kinetic energy. If the speed of the car can be doubled, then its energy will not be doubled but it will increase four times. That's why damages of a car accident depend on speed. The damage is much greater when a car meets an accident due to its high speed



Image: The sculpture of a car damaged in an accident

Transformation of energy

There is no destruction or creation of energy; there is only transformation. So, if a car starts from a steady state and moves slowly, then the energy created in it must have been transformed from some other energy. Can you tell where this energy is transformed from?

A little thought will tell you that the energy is generated by the engine of the car and the car engine has used fuel, petrol, diesel or gas to generate that

energy. The energy available in this fuel is called chemical energy. This chemical energy also comes from the heat and pressure of the earth for millions of years. Chemical energy is our familiar energy. The chemical energy available in the battery of our telephone comes out as electrical energy during use. When the stored chemical energy lessens, we can transform the electrical energy as chemical energy by conducting electricity as we charge the battery. We transform electrical energy into light when we light a lamp in a house, we convert it into heat when we use a heater, we transform it into sound when we hear music on a loudspeaker, and we convert it into kinetic energy when we run a fan. So, if you think a little, you will see that energy is not born or destroyed but it is only transformed from one form to another.

Potential Energy

Energy can be stored inside a battery as chemical energy and can be used as needed. We can store energy in other ways if we want. If a piece of stone lies on the floor, there is no energy inside it. But if the piece of stone is lifted and placed on a table, then a kind of static energy will be stored in the piece of stone. Because if we knock and throw a piece of stone down from the table, motion will be created inside as it falls down- the more down it falls, the more dynamic it will be. We now know that if there is motion, there is kinetic energy. Therefore, kinetic energy will be created in the pieces of stone. This kinetic energy has been possible due to lifting the piece of stone up the table.

Hydroelectric power plants generate electricity using static energy. Here water is stored in a river or lake by making a dam, then the water is brought down from a great height and the power is used to generate electricity by turning the generator.

Measurement of energy

The unit of energy is called joule. When one joule of energy is consumed per second,



Image: Kaptai Hydroelectric Power Plant

it is called watt. You may not have heard the name of the unit joule but you must have heard the word watt. When you buy a useful electrical appliance, you check how many watts of electricity is required for that device is written on it.

Transmission of energy

Among the types of energy we are familiar with, the simplest energy to use is called electricity. Lights and fans can be easily turned on, refrigerators and computers can be easily run using electricity. So, arrangements are made to supply electricity to all our homes in the cities, villages and even in remote areas. That is why, electricity has to be taken from one place to another and supplied to all homes, factories, offices or schools and colleges. You must have seen that electricity is distributed everywhere through electric lines very carefully and cautiously. We also supply and distribute gas from one place to another through pipes. Gas is not a direct energy but heat is generated from its stored energy, which is used to create other energy.



Image:
Electrical
energy is
transmitted
through
high voltage
electrical lines.

.....The most amazing formula in history.....

The most amazing and most famous formula in history is related to energy. Scientist Albert Einstein gave this formula of energy. According to this formula, there is no difference between mass and energy of an object. If the mass of the object is m and the speed of light is c and if this mass is converted into energy, then the amount of energy E will be:

$$E = m(c \times c)$$

Since the velocity of light is much higher, transforming mass into energy produces an unimaginable amount of energy. While writing the formula, c^2 is written in stead of writing $c \times c$. That means, the form of the world-famous formula is,

$$E = mc^2$$

This is how energy is generated in a nuclear power plant. If the sun were to generate energy with ordinary fuels, it would have run out of energy and doused long ago. But the Sun also produces energy in the process of $e=mc^2$. So, it has been giving energy for 5 billion years, and will continue to give another 5 billion years in the future!

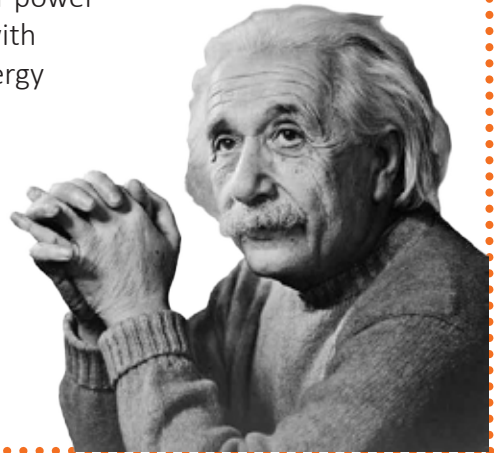

Exercise

?

1. Give some examples of forces that can be applied without touching.
2. Describe how your daily life would be if there were no friction force on Earth.
3. If 1 kg mass is converted into energy, how many 100-watt bulbs can be kept lit for 24 hours with that energy?

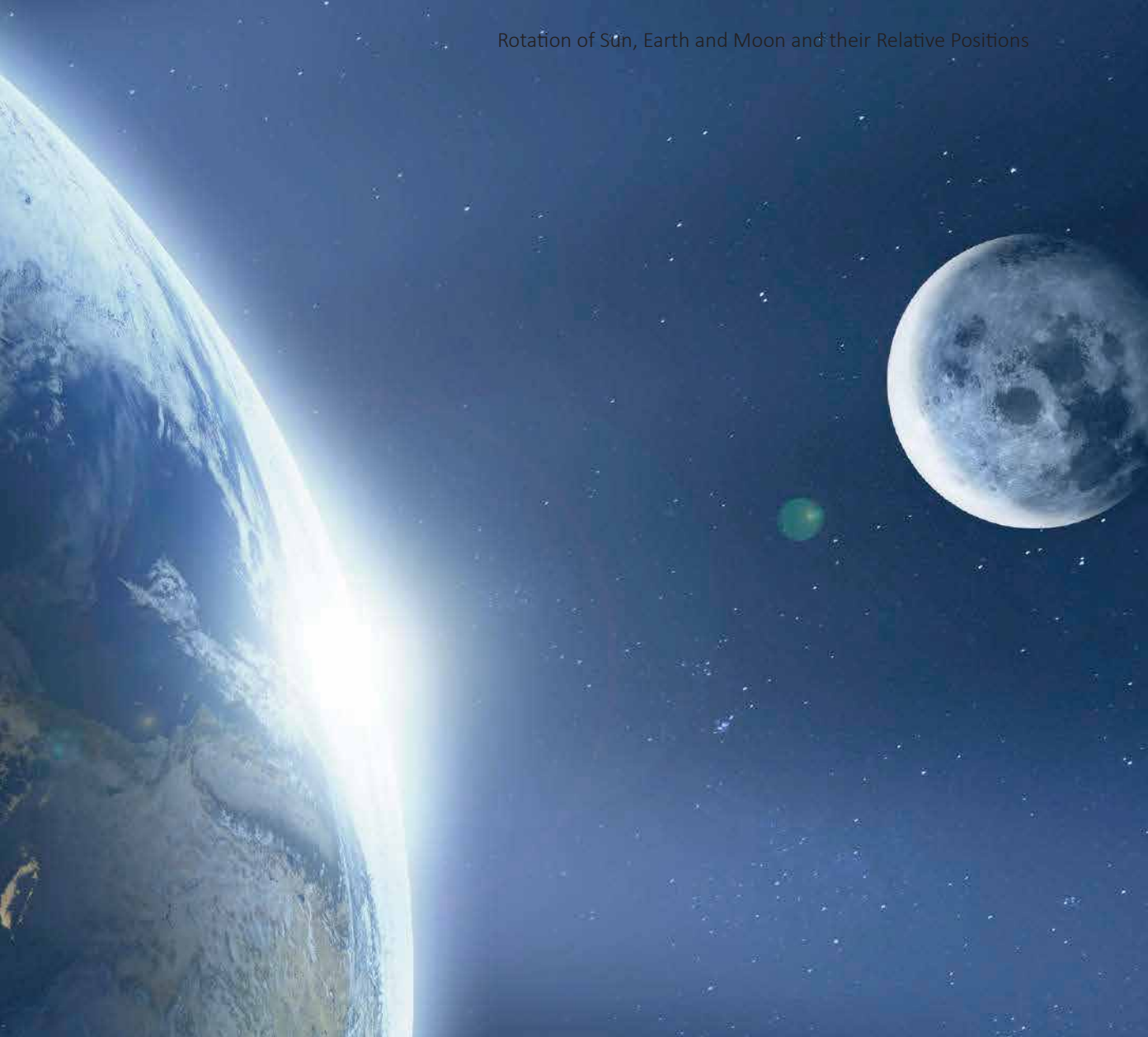

Chapter 9

Rotation of Sun, Earth and Moon and their Relative Positions

**Chapter
9****Rotation of Sun, Earth and Moon and their Relative Positions**

At the end of this chapter, students will be able to know the following:

- ☑ Changes of day-night and seasons
- ☑ Diurnal motion and annual motion
- ☑ Geographical lines
- ☑ Differences of weather in different regions of the earth's surface
- ☑ Moon's effect on the earth
- ☑ Relative positions of sun, earth and moon

In the solar system, the earth revolves around the sun. Again, the moon revolves around the earth. That is why the relative positions of the earth, sun and moon change at different times of the year. This change also causes the change of day and night, the new moon-full moon and the change of seasons in the earth.

Changes of day-night and seasons

You must have noticed that the lengths of days and nights of the year are not always equal. Summer days are long, with plenty of time for sports after school in the afternoon. In winter, the day is smaller. It is observed that the sun rises very late in the morning and again the evening comes down much earlier. All of this is due to the rotation of the earth around its own axis or diurnal motion and due to the orbital of the earth around the sun or annual motion.

Diurnal motion

The earth is not stationary in space; it revolves around its own axis. The direction of this rotation is from west to east (image1). That is why we see the sun rising in the east and setting in the west. As a result of this rotation, a cycle of light and darkness from the sun in different parts of the world ends in 24 hours, which we call day-night. If the earth rotated fully vertically on its axis, then there would be 12 hours of day and 12 hours of night in all parts of the world. But since the earth rotates on its own axis at an angle of 23.5 degrees, day can be longer in

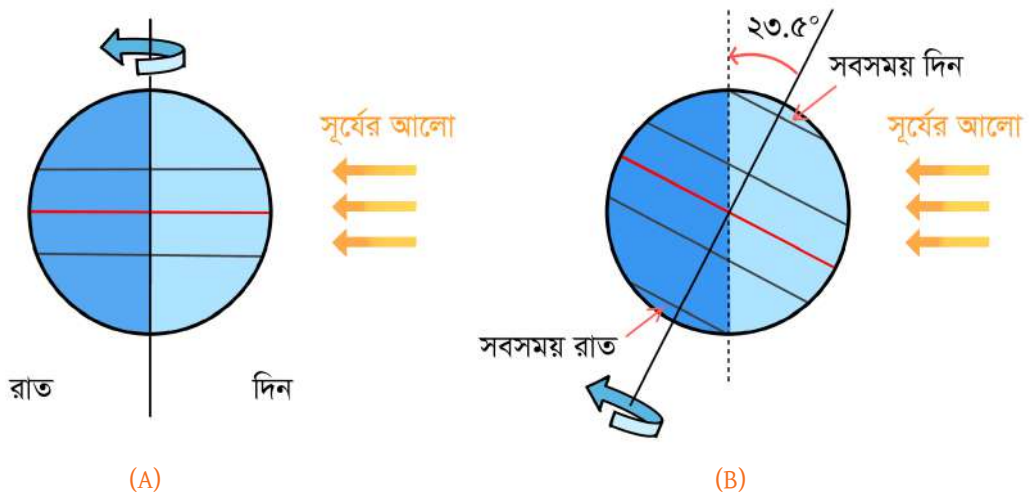

(A) If the earth rotated vertically on its axis, there would be 12 hours of day and 12 hours of night everywhere. The seasons would not change. (B) Since the earth rotates at an angle of 23.5 degrees relative to its orbit, days are longer somewhere and smaller somewhere.

some places, shorter in some places or even there can be continuous days for many days and continuous nights for many days near the north and south poles.

Annual motion

The earth revolves around the sun once every 365 days 5 hours 48 minutes 47 seconds. After 365 days per year, the additional 5 hours 48 minutes 47 seconds is left and after four years this additional time increases to almost one day. So, in order to make for this lapse, in every year divisible by four, the month of February is calculated for 29 days instead of 28. These years are called leap years. A complete rotation of the earth around the sun is called annual motion. We count this time as a year on the earth. In the meantime, you have come to learn that the length of days and nights changes because the rotational axis of the earth is not fully vertical and earth tilts at 23.5° (twenty-three and a half degrees). The more vertically the sunlight falls on a place,

the hotter the sun will become and the more heat the place will get. At other times of the year, the sunlight will reach curved. Then, the sunlight will have less heat as it spreads over a large area. That is why the seasons on earth change. But first we see what is meant by earth's tilting at an angle of 23.5° on the axis. If we consider the axis of the earth as a flat surface or a dish and imagine a perpendicular on it, the axis of the earth will produce an angle of 23.5° with that perpendicular.

Geographical lines

In order to analyze the geographical location of the earth, a few imaginary lines have been thought on it. The most important of these lines is the equator (or equatorial line) and it extends east-west through the center of the Earth. The equator divides the earth into north and south hemispheres. The next two important lines are the Tropic of Cancer and the Tropic of Capricorn. The Tropic of Cancer is 23.5 degrees north of the equator and the Tropic of Capricorn extends 23.5 degrees east and west to south (image). You will be happy to know that the Tropic of Cancer has passed right through the middle of our Bangladesh and that is why we get some amazing experiences on certain days of the year! Besides the equator, there are other important geographical lines that you will learn about later.

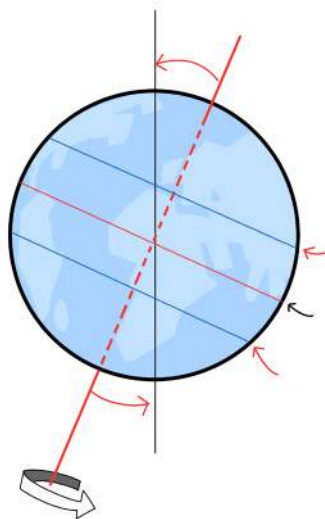

Image: In order to analyze the geographical location of the Earth, it has been divided into several imaginary lines such as Equator, Tropic of Cancer and Tropic of Capricorn.

Seasons

The 365 days of the Earth's year are divided into several sections depending on the weather, length of day and night, and various changes in nature. These divisions of the year are known as seasons. In most countries, the whole year is divided into four seasons- winter, spring, summer and autumn. Our country is one of the very rare countries which has its own calendar and uses the Bengali months. According to it, the whole year is divided into the following six seasons:

- » Summer : Boishakh and Joistha (mid-April to mid-June)
- » Monsoon : Asharh and Shrabon (mid-June to mid-August)
- » Autumn : Bhadro and Ashwin (mid-August to mid-October)
- » Late Autumn : Kartik and Agrahayan (mid-October to mid-December)
- » Winter : Poush and Magh (mid-December to mid-February)
- » Spring : Falgun and Chaitra (mid-February to mid-April)

The region near the equator is called the equatorial region, where the change of seasons is not very well felt as the sun's light falls almost vertically throughout the year. When the earth revolves around the sun, the sun's light falls differently in different parts of the world at different times of the year. For example, the sun's light falls fully vertically on the Tropic of Cancer on June 21 (image). That is the longest day in the north hemisphere. Because of being the longest day and sunlight's falling vertically, this time is the summer for the north hemisphere. Again, at this time, if we look at the sun from above the Tropic of Capricorn for the south hemisphere, it seems that the sun is tilted north at an angle of 23.5 degrees. Days are shorter and nights are longer. Due to shorter days and the tilted sun's light, it is winter for the south hemisphere.

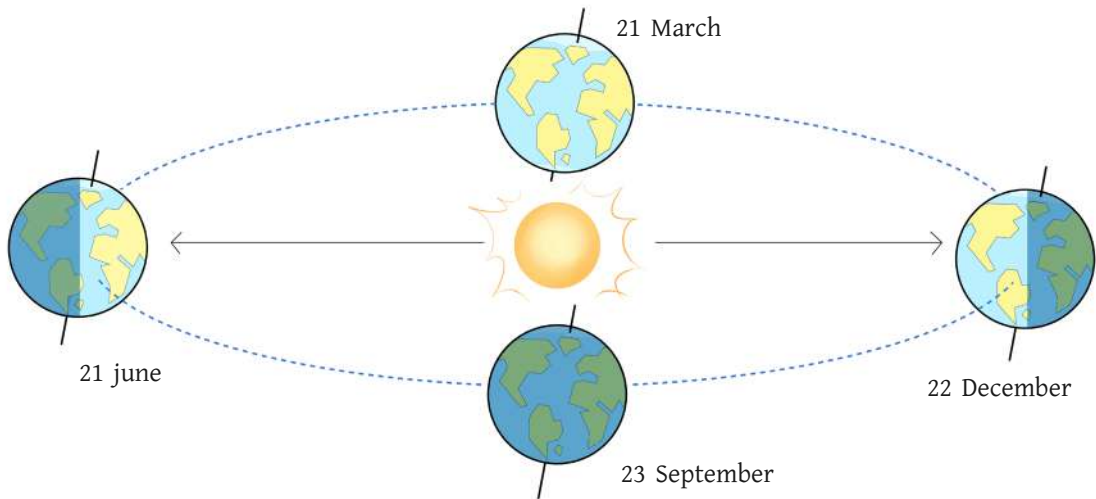

Image: On June 21, the sun's light falls vertically on the Tropic of Cancer. This time is summer for the north hemisphere and winter for the south hemisphere. On December 22, the sun's light falls vertically on the Tropic of Capricorn and that time is summer for the south hemisphere and winter for the north hemisphere.

the longer days and sunlight's falling vertically, this time is the summer for the south hemisphere. You must be able to guess that if you look from above the Tropic of Cancer, it seems that the sun is tilted to the south at a maximum of 23.5 degrees. During the middle of June 21 and December 22, that is on March 21 and September 23, the sun's light falls right in the middle of the Tropic of Cancer and the Tropic of Capricorn, that is, on the equator. You understand that then day and night are exactly of twelve hours. This results in a feeling of cold and hot weather at this time. These days were very important to many ancient civilizations. Many of their social and religious rites were observed following these days.



Differences of weather in different regions of the earth's surface

Different types of weather are seen in different parts of the world. In Bangladesh, for example, summer, monsoon and winter are quite well felt. During the monsoon season, our country experiences a lot of rainfall. Again, the winter of our country cannot be compared with the winter of the polar region. Areas near the Polar Regions are cold most of the year. Even some areas are covered with snow all year round. The climate in Africa, Saudi Arabia, etc. is mainly tropical and dry. The difference of climates in different areas depends on the location of the area, presence of waterbody or water, presence of plants and forests etc. But at the root of everything is the amount of solar energy (light and heat). In the areas of the equator, Tropic of Cancer, Tropic of Capricorn, and around it, sunlight falls vertically or at an angle of around 90° . So, the weather is warm in all these areas. In the polar region and its adjoining areas, the sun's rays fall diagonally or curved, so there is less warmth and more winter. However, the height of an area can also determine the climatic characteristics of that area. In high mountains, for example, temperatures may be much lower than in plains of the same latitude. This is because, in the lowest level of the atmosphere, the higher we go, the lower the air temperature becomes.

Moon's Effect on the Earth

Crescent/Lunar Phase (Chandrakala)

You all are fascinated by the moon in the sky. The moon rises in the east and sets in the west, just like the sun, for the diurnal motion of the earth. From one day to the next, the shape and size of the sun does not change, but we see the shape of the moon changes. The full moon disappears completely in the new moon as it fades away. The new moon gradually grows bigger and becomes the full moon. In fact, the shape of the moon does not change. The moon does not have light of its own. We can see the part of the moon on which the sun's light falls. The size of the illuminated part

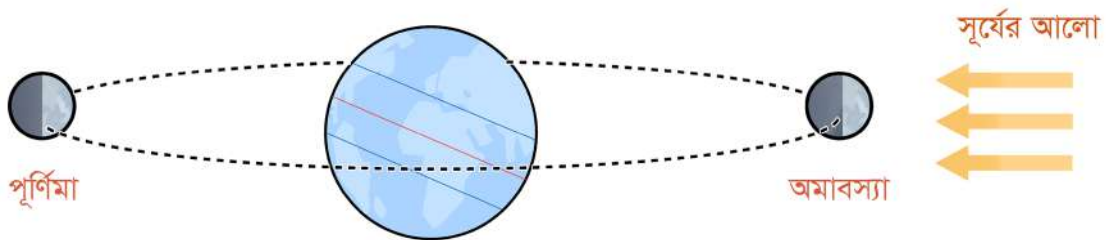

Image: When the full moon is fully illuminated by the sun's light, we call it full moon. When the opposite side of the moon is illuminated, we cannot see the moon and we call it the new moon.

of the moon changes daily when the moon rotates around the earth. It occurs because of its position relative to the sun. There is a beautiful name for this change in the illuminated part of the moon, that is crescent (Chandrakala).

In order to understand the crescent (Chandrakala), we have to know where the moon is relative to the earth and sun. When the moon is between the earth and the sun during the rotation, the back of the moon is illuminated by the sun. Then, the moon remains invisible from us because we cannot see

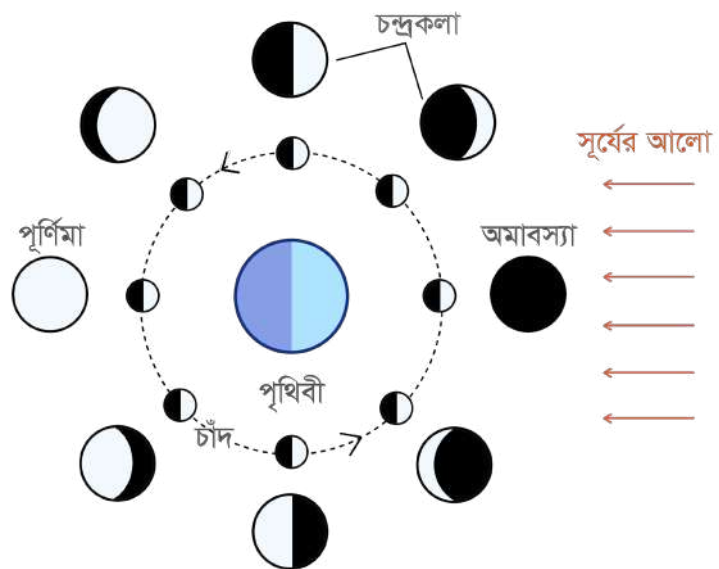

Image: The inner circle shows the actual position of the moon and its illuminated part. The outer circle shows what it would look like to see the moon from Earth.



that illuminated part from the earth and we call this time the New Moon. When the moon rotates slowly around centering the earth, the illuminated part of the moon begins to be seen little by little from the earth. When the illuminated part of the moon begins to be seen and the moon remains behind the earth relative to the sun, the full moon becomes visible, and we call it the Full Moon. Due to the rotation of the moon, the visible part of the moon gradually decreases and at time disappears completely in the New Moon. When the visible part of the moon continues to increase, it is called the Waxing Moon period (Shuklapaksha) and when it continues to decrease, it is called the Waning Moon period (Krishnapaksha).

The moon revolves around the earth once every 27 days and 8 hours. But it takes 29 days and 12 hours to see a new moon from another new moon. This is because when the moon revolves around the earth, the earth also travels a short distance around the sun. So, the moon has to revolve a little more to reach the same place relative to the sun. Those of you who have noticed the moon in the sky must know that we always see one surface of the moon, never see the other surface. This is because the moon revolves the earth in such a way that one side of the moon is always facing the earth. We have seen the back of the moon for the first time in captured picture during the recent expedition to the moon.

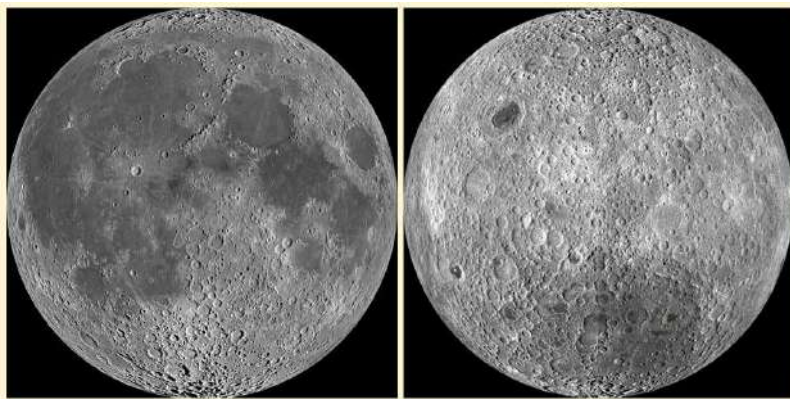

Image: We are accustomed to seeing the surface of the moon, shown on the left. The image of the opposite side of the moon captured by the spacecraft is shown on the right.

Ebb and Tide

Those of you who live near the sea must have noticed that the sea and river water there rises and falls twice a day. These regular rise and fall of sea and river water levels in coastal areas are called ebbs and tides. You all know that due to the gravitational force everything attracts all other things. As such, the sun and the moon also attract everything on the earth. The Sun's attraction to the earth is much greater than the moon's attraction. But surprisingly the incident of ebb and tide on the earth is mainly due to the moon's attraction. The reason is not the total amount of attraction on the earth, but the difference in attraction in different parts of the earth.

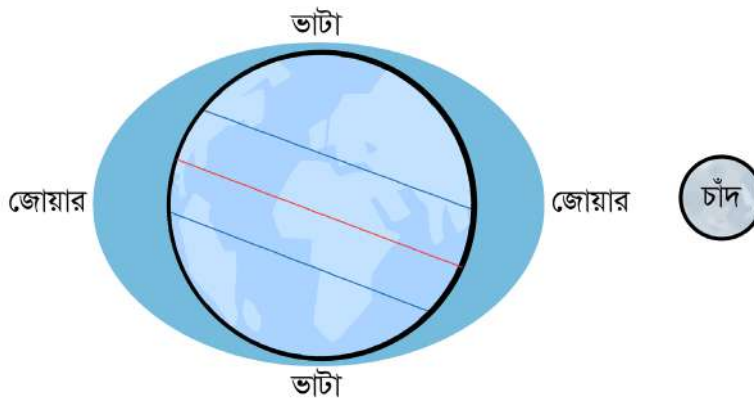

Image: When the water of the earth increases due to the attraction of the moon, it is called tide. The water moves away from the other place to increase, and it is called ebb.

As the sun is so far away from the earth, the difference in its attraction in different parts of the earth is less. As the moon is relatively closer to the earth, the difference in the attraction of the moon in different parts of the earth is much greater. That's why the moon attracts the water from the part of the earth that is just below it and swells it and we call it tide. Again, at that time, the force on the water on the opposite side of the moon's position is the least. It can be imagined that the force is working in the opposite direction there. So, the water is swollen in the opposite direction also and tide occurs. The part where the water level goes down to swell the water level on both sides at the same time is called ebb. At the same time, there is ebb on the opposite side of the place like the tide. That is, the water of the sea, ocean and coastal areas rises and falls four times a day. In that case, the ebb and tide is supposed to be after six hours. But our moon revolves around the earth and the position of the moon changes over time. So, the ebb and tide occur after a little over six hours. Ebbs and tides are mainly due to the moon, but the position of the sun also plays a role here. When the moon, the earth, and the sun are in a straight line, the water of the tide swells a little more and the water of the ebb goes down more. In this case, the force of attraction of the sun and the moon work in the same straight line. So, water is attracted more. This condition is called Spring Tides. Spring Tides occur during every full moon and new moon. Again, when the sun, earth and moon are at right angles, the water level swells

slightly towards the sun due to the position of the sun. This is why tide water rises a little lower and ebb water goes down a little lower. The intensity of the ebb and tide decreases. This condition is called Neap Tides.



Image: When the water of the earth increases due to the attraction of the moon, it is called tide. The water moves away from the other place to increase, and it is called ebb.

Relative Positions of Sun, Earth and Moon

Besides tide-ebb and Chandrakala, two more incidents are also observed as a result of the changes in the position of the sun, earth, and moon. These are solar eclipse and lunar eclipse.

Solar and Lunar eclipses



Image: Solar eclipse

Solar eclipses are not very frequent. So, you probably did not have the opportunity to observe the solar eclipse so much. But you must have had the opportunity to see a full or partial lunar eclipse at some point. During a lunar eclipse, the full moon suddenly begins to be covered by a circular shadow. The moon is covered fully or partially depending on the full or partial lunar eclipse. Again, the solar eclipse occurs during the new moon, when the sun begins to be covered in a circular shadow. Sometimes, during the day it gets dark and a mysterious atmosphere is created. It's therefore not very strange that in ancient times, people used to make strange stories with different kinds of superstitions as they did not know what actually happened during the eclipses.

Now we know the matter is actually very



Image: Different stages of a full lunar eclipse

simple. The moon revolves around the earth. While revolving, it comes between the sun and the earth during every new moon. If by chance the earth, the moon and the sun appear in the same straight line, then the sun is covered by the moon. This event is called solar eclipse. If the sun is completely covered by the moon, it is called a total solar eclipse. If the sun is partially covered by the moon, that is, the partial shadow of the moon falls on the sun, a partial solar eclipse occurs.

Right in the same way the moon appears behind the earth in every full moon. Then,

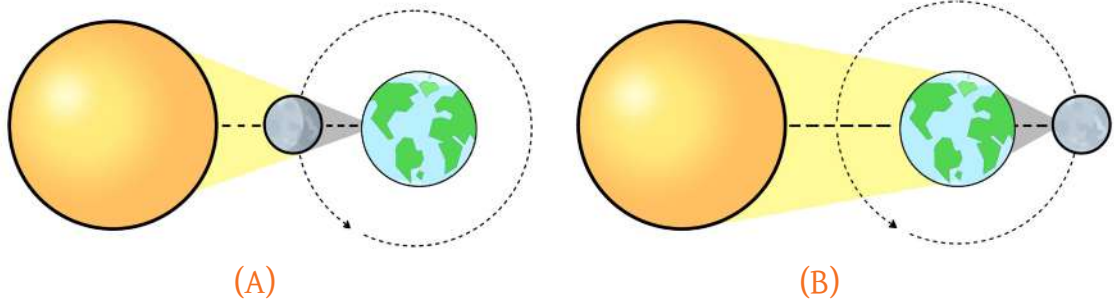

Image: (A) When the moon comes between the sun and the earth in the New Moon, the sun is covered, which we call solar eclipse. (B) On the night of the Full Moon when the shadow of the earth falls on the moon, we call it lunar eclipse.

if by chance, the moon, the earth and the sun appear in the same straight line, the shadow of the earth falls on the moon and we call it lunar eclipse. If the moon is completely covered by the shadow of the earth, it is called a total lunar eclipse. If the moon is partially covered by the shadow of the earth, that is, the partial shadow of the earth falls on the moon, then a partial lunar eclipse occurs.

You might have the question, why there are no solar and lunar eclipses in every New Moon and Full Moon? If the moon rotated the earth from the same surface of the earth's orbit, then lunar eclipse and solar eclipse could be observed in every New Moon and Full Moon. But the moon rotates the earth at an angle of 5 degrees. Therefore, it cannot appear in a straight line connecting the sun and the earth in every Moon. However, by calculating in advance, we can predict when there will be lunar and solar eclipses. On June 30, 1503, Christopher Columbus predicted a lunar eclipse for the simple indigenous people of Jamaica. He deceived and frightened them by calling it a curse of God and thus arranged their own food and supplies.

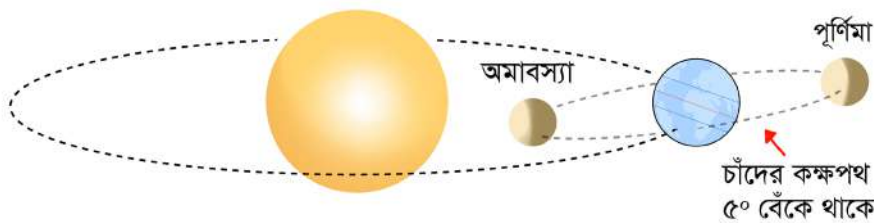

Image: The Moon's orbit is inclined at an angle of 5 degrees relative to the Earth's orbit

Exercise ?

1. If you see the moon in the sky shown in the picture, then can you say, whether the moon is in Waxing Moon period or Waning Moon period?
2. Can you figure out which area of Bangladesh the Tropic of Cancer passes over?
3. If you want to install solar panels on the roof of your house, which direction should it face and why?



Chapter 10

Properties of Matter and its External Effects

Chapter 10

Properties of Matter and its External Effects

At the end of this chapter, students will be able to know the following:

- ✓ Different properties of matter
- ✓ Classification of matter based on properties
- ✓ Use of metals and non-metals, precautions and preservation techniques
- ✓ Measurement of thermal and electric conductivity of metals and non-metals by experiments
- ✓ Determination of melting point and boiling point by experiments
- ✓ Distortion of the shape of metals and non-metals
- ✓ Cooling process
- ✓ Safety and caution during experimental work

Properties of matter

You have already known that matter occupies space and has mass, and in nature matter is found in these three states- solid, liquid and gaseous. In addition to these three states, matter has some other properties. For example, density, solubility, solidity, flexibility, thermal and electric conductivity, magnetism, etc.

Density

You know that the mass of an object in a unit volume is called density. Density is an important property of an object. You must have noticed that different matters have different density; some have more, and some have less density. Metals such as iron, copper, brass have higher density, wood or plastic has lower density and air has the lowest density.

Solubility

Another important property of matter is its solubility, which you will learn about in more detail in the next chapter. We can say for example, salt dissolves in water but does not dissolve easily in oil. Again, nail polish does not dissolve in water but dissolves very easily in acetone.

Solidity and flexibility

When you press different objects with your hands, you can see that some of them are easily compressed, and some are very hard, which cannot be easily compressed.

Because of this compression quality, we term substances as soft or hard, flexible or inflexible. This can be easily understood through the following task:



Activity: Take a metal key and use it to put a mark any object including a piece of wood, aluminum, stone, candle wax, chalk, rubber etc.

You can easily make a mark on some objects and not easily on others. Now, make a table of hard, soft, flexible and inflexible matters based on your observations. Matters that are easily compressed and marked are called soft, and those that are not easily compressed and hard to mark are called hard objects. For example, wax is a soft matter, while iron is a hard matter.



Thermal and electrical conductivity

Conduction of heat and electricity is another important property of matter. Matters in which heat can easily be conducted are called thermal conductors and the matters in which heat cannot be easily conducted are called non-thermal conductors. Similarly, matters in which electricity can easily be conducted are called electric conductors and the matters in which electricity cannot be easily conducted are called non-electric conductors. Gold, silver, copper or aluminum etc. are examples of thermal and electric conductors at the same time.

Magnetism

All of you must have seen or used magnets. Some matters have magnetic properties. They can attract or repel other magnetic matters. Iron, nickel or cobalt are examples of magnetic matters.

Identification of matters by properties

Different matters have different properties. So, we can identify different substances by using their properties. For example, if a matter is attracted by a magnet, we can say that it must be a magnetic substance. If it conducts heat and electricity, it is probably a kind of metallic substance. Even if it dissolves in a certain type of liquid, we can still find important information about the matter. The density of matter also helps us to identify the matter.

Using right thing to do the right work by knowing the properties of the matter

If you want to build a house, you need bricks, stones and iron. If you want to build a boat, you need wood. Again, pots and pans made of aluminum are used in cooking as it is heat-conductor and easily available. We use electrically conductive copper wire to conduct electricity. Again, we use paper for printing books and widely use lightweight but durable plastic to make children's toys. Thus, it is seen that each thing has its own characteristics. By knowing these characteristics, they can be used properly.

Metals and non-metals

Everything around us is made up of some basic matters. All of these basic matters can be divided into metals or non-metals. So, it is very important to know about metals and non-metals and to differentiate between them. Now you can learn about some properties of metals and non-metals.

Physical properties of metals

Metals are generally of high density, are shiny and conductors of heat and electricity. Mercury is an exceptional liquid substance, and all other metals are solid substances. Sodium and potassium are soft and can be cut with a knife, but all other metals are hard. Metals are malleable and flexible. So, they can be turned into sheets by pressing or into long wires by pulling them. Gold, silver, copper and aluminum are some of the known metals.



Physical properties of non-metals

Non-metals do not show physical properties like metals. These, for example, do not shine, are not generally heat and electricity conductor, and are fragile. Non-metals are not extensible and malleable. So, it is not possible to make sheets by pressing them or long wires by pulling them. They have low density, and many non-metals, such as nitrogen or oxygen, have gaseous conditions at normal temperatures. Carbon (coal) is a non-metal known to us.

Different Properties of Metals and their Experiments

Shiny



Activity: Take aluminum pots, plastic scales, wooden scales and steel scales. Leave them in the sunlight. Then observe which ones shine, and which ones don't. Write the results of the observations in a table.

Thermal conductivity

Thermal conductivity refers to the exchange of heat through a matter or through two different matters in contact. Heat is always transported from high temperature to low temperature. Heat will flow faster if a conductive matter is used for this transport. If non-heat conductor matters are used, heat flow will be slower. Metals are generally more heat-conductor than non-metals. That is why they are very effective in transporting heat. You can try the following experiment as proof of the thermal conductivity of metals:



Necessary equipment: Aluminum rod any metal rod. or thin metal wire, matches and candles.

Activity: First light the candle. Now carefully hold one end of the metal rod or wire with your hand and hold the other end in the candle fire. In this way, hold the wire until you feel warm in your hand.

Now the question is why do you feel hot on the end of the wire in your hand? Metal rods or wires are heat conductors. So, the heat absorbed at the end of the candle flame is transmitted to the end you are holding. In fact, all metals conduct heat.

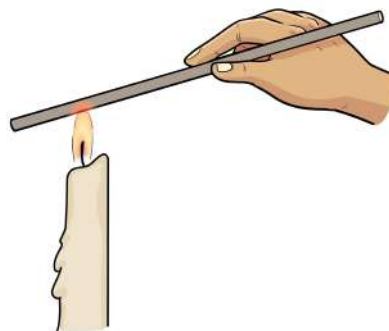

Use of metals as heat conductors

A) Heat transport is very important in refrigerators, air conditioners, solar panels. Therefore, various types of thermal conducting metals are used in this type of machines.

B) Metals are widely used in electronics, engineering, laboratory equipment, medical instruments, household appliances and especially in construction industry.



Activity: Different matters have different thermal conductivity. You can test it by the following experiment.

Necessary equipment: A wooden spoon, a plastic spoon, a metal spoon of approximately the same size, 3 one-taka coins, a pot for heating water, a glass of water, a candle or something else for heating, candle wax, a match and a clock for measuring time.

Procedure: Melt the candle wax with a little heat. Put a small amount of soft candle wax on the handle of all the spoons. Now put pressure and place the coins on the candle wax in the spoons in such a way that the coins stick to the candle wax. Now dip the spoons in the pot in such a way that the coins remain outside the top of the pot. Then continue heating the pot with a candle or something else.

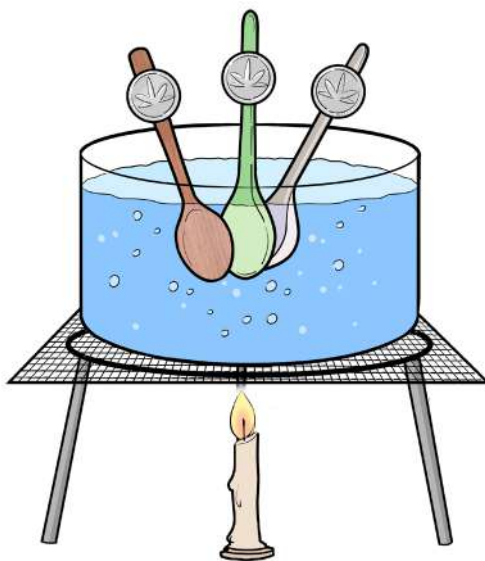

Now observe the conditions of the coins stuck to the spoons. Are the coins separated? If so, which one has separated first? How long did it take to separate? How long did the other coins take to be separated? Undoubtedly you will see that the coin to separate first is from the metal spoon. Since the metal spoon is separated first, it means that the metal spoon is more heat-conductor than the other two (wooden and plastic).

The heat is transmitted from the hot water and reaches the metal spoon faster than the wooden or plastic spoon. That is why the candle wax of the metal spoon melted quickly and the coin was separated. On the other hand, since the conductivity of plastics is lower than the others, the heat travels very slowly from the warm end to the cold end. As a result, you will see that the candle wax of the plastic spoon has taken the longest time to melt and at the end of all, the coin of this spoon has been separated.

Electric conductivity of metals and non-metals

Almost all metals are electric conductor, but their conductive capacity is different. For example, silver is the best conductor of electricity and copper and aluminum are also good enough conductors. However, because of the high price of silver, it is not used as an electrical wire, but copper and aluminum are used instead.



Activity: We can easily examine the electric conductivity of different matters.

To do that you need a battery, some copper wires and a diode. (You can also use a torch light bulb instead of a diode if you wish, but nowadays diodes of various colors are easily available at a low price). Now, make a circuit as shown in the picture and connect the diode to the battery and light it. You will see that if you connect one side of the battery, the diode will light up, if you connect the other side, it will not light up. This is because electricity flows to only one side through the diode.

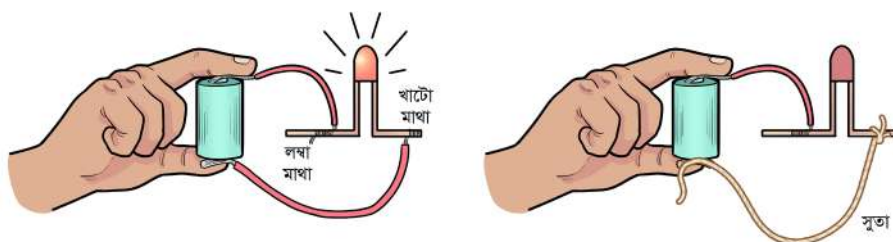

Copper is an electric conductor. So, it can carry the electricity of the battery through the diode and for this reason the diode lights up. If the copper wire were not electric conductor, it would not be able to transfer electricity and the diode would not light up.

This time, in the way shown in the picture, you can examine to see what happens by putting iron, aluminum, cotton yarn, paper, rubber, plastic, wood and even water on the copper wire part! You will see that the diode lights up in some place and does not light up in some place. If the diode does not light up even after completing the circuit with a certain object, then it is to be understood that the object is not electric conductor.

Change of metals by applying force

You must have heard the ringing of your school bells. If you had a plastic or wooden bell in place of the metal bell, you probably wouldn't hear the bells' ringing nicely! It is a property of metals to make a special jingle or ringing sound when it is hit. Sheets can be made by hitting metal. You will surely be surprised to hear that a piece of gold of a centimeter thickness can be spread to a very fine sheet equal to a football field! If you examine the old aluminum cauldron or kettle in your kitchen, you will see that it has become hollowed and uneven in various spots. Its reason is that its size has changed due to hitting during use. This is a very common process for metals. This would not have happened if the pot or kettle had been made of glass or ceramics instead of metal. From what you see around you, can you figure out some more examples of metal reshaping by hitting or applying force?

Melting Point and Boiling Point

Melting point and freezing point

The temperature at which a solid substance changes its state and turns into a liquid substance is called the melting point of that solid substance. Again, the temperature at which a liquid substance changes its state and turns into a solid substance is called freezing point. The melting point and freezing point are actually the same temperature. To give an example, when the water temperature drops to 0 degree Celsius, it starts to freeze. Again, the temperature of the frozen ice starts to increase and increases to 0 degree Celsius, it starts to melt into water. The melting point of candle wax is 57° C. How do you determine that? Or what does it mean? You can determine that using a thermometer to measure the temperature. A thermometer used for measuring our fever can only measure temperatures close to our body temperature. So, you need a thermometer that can measure your temperature from 0 degree to 100 degree. Your teacher can help you in this regard and show you the experiment in the school laboratory. Melting point and freezing point are the same temperature. So, this experiment will determine both melting point and freezing point at the same time. If there is a slight difference between the two, then taking their average will bring the result closer to the actual temperature.



Activity:

1. Take a few pieces of candle wax in a test tube.
2. Take some water in a beaker or any other container and using wire gauze, place it on top of the spirit lamp or anything else suitable for heating as shown in the picture.
3. Dip the test tube including the candle wax in water with a rod and insert a thermometer into the test tube.
4. Use a spirit lamp to heat the bottom of the beaker.
5. Observe the reading of the thermometer and notice the condition of the candle wax in the test tube.

You will see that the reading of the thermometer is increasing. When the temperature of the thermometer reaches 57 degrees Celsius, carefully observe the condition of the candle wax.

6. When the candle wax begins to melt, notice the reading of the thermometer. This is the melting point of the candle wax and its value is supposed to be around 57 degrees

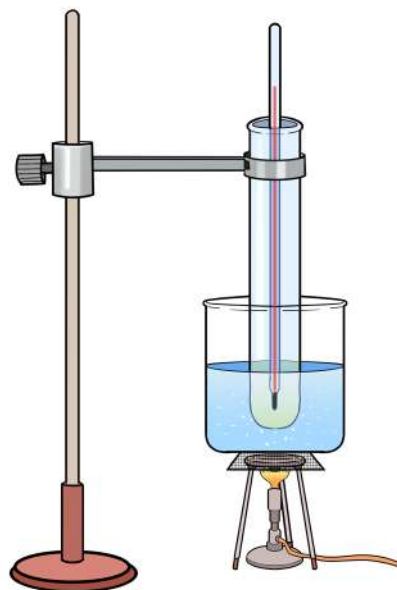

Celsius. However, remember that the value of the melting point can be a little higher or lower depending on the wastes in the object.

7. After the candle wax is completely melted, the temperature of the melted candle wax will start rising again.

8. Remove the beaker, wire gauze and lamp from the bottom of the test tube along with the thermometer.

9. This time, the temperature of the melted candle wax will continue to decrease. Observe the temperature of the thermometer, notice the temperature the candle wax has started to solidify.

10. The temperature at which the candle wax begins to solidify is the freezing point of the candle wax.

Finalize your result with the average of melting point and freezing point which were determined separately.

Boiling point

The temperature at which a liquid changes its state and turns into a gas is called a boiling point. You must have seen water boiling in a kettle or any pot in the kitchen. The water starts to evaporate. The temperature at which water begins to evaporate or begin to boil is called the evaporation point or boiling point of water. The boiling point of water is 100 degrees Celsius. Like water, every liquid has a specific boiling point. You will also be able to find the boiling point of water as you determined the melting point with the help of your teacher.



Take water in a pot or beaker as shown in the image.

2. Place the beaker or pot on a spirit lamp or something that can be used to heat. Dip the thermometer in distilled water with a rod.

3. Now use heat and keep noticing the temperature of the thermometer.

4. When the temperature of the thermometer rises to 95 degrees Celsius, carefully observe the condition of the water in the beaker or pot.

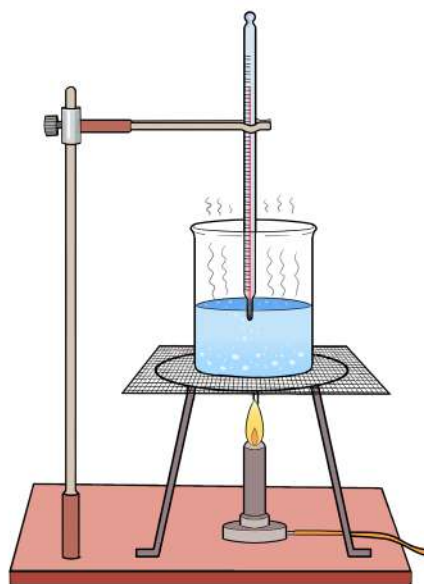

5. When the water starts to boil, notice the temperature of the thermometer. This is the boiling point of water. If you take pure water, the boiling point will be close to 100 degrees Celsius.
6. If something else is dissolved in water, its boiling point may be different. To test it, mix a teaspoon of salt with water and see the boiling point of this water.

The boiling point of any liquid actually depends on the pressure of the air. At a higher place, the air pressure is lower. So, water boils at lower temperatures and takes more time to cook. Again, it is possible to cook faster with a pressure cooker because the pressure cooker artificially increases the air pressure and increases the boiling point of water.

Exercise



1. Notice, among the kitchen utensils of different shapes, which one is used in which cooking. What is the reason for their different shapes?
2. Say why coconut oil freezes hard in winter?

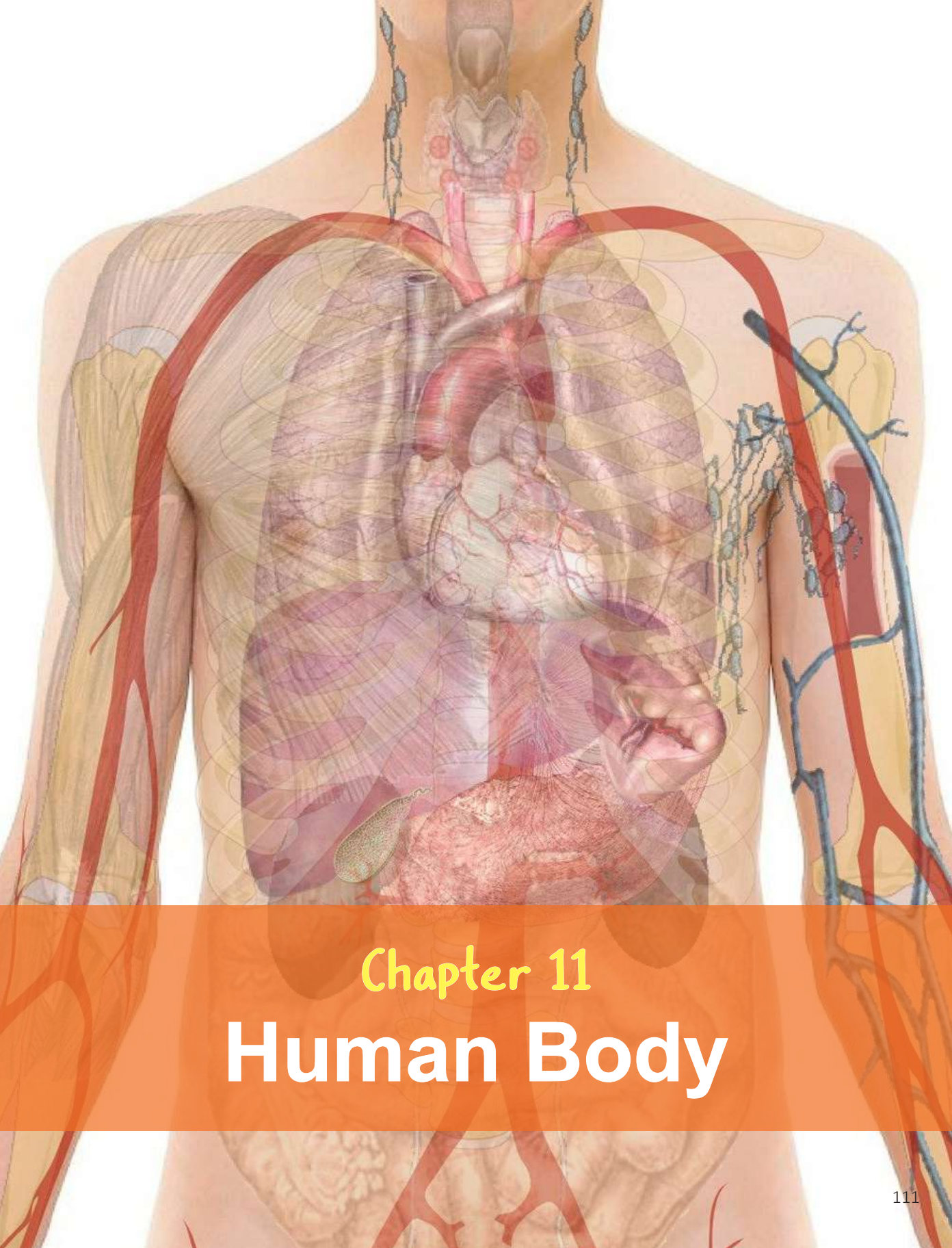

Chapter 11
Human Body

Chapter 11

Human Body

At the end of this chapter, students will be able to know the following:

- ☑ The physiological position of human in animal kingdom
- ☑ Organs of the human body
- ☑ Structure and function of vital organs
- ☑ Body care and healthy habits

What is meant by Fossils?



Fossils are body parts of any organism of prehistoric period that are buried under the ground, or otherwise stored for many years. The largest source of information about the plants and animals of the ancient world is the specimen of fossils found of that time. For example, we all know about dinosaurs. These gigantic creatures once freely moved in the earth. In the days of the dinosaurs, there were no humans. So, no one even saw them! But now so much is known about these animals. Its main source is the fossils of dinosaurs found in various places.

We can see different kinds of creatures around us. Such as trees, martins, pigeons, chickens, ducks, fish, cats, dogs, goats, cows, etc. In addition to these, the creature that we see a lot is human. Humans also live like all other living things. He can move. So, he is an animal.

Since our childhood, we have wondered “Where have we come from” and thought “How are we different from other animals”. We also have special features like all other living things. We look different from other animals. Our style of walking, eating habits, thinking ability- all have some different features compared to other animals. “Modern” humans (scientific name *Homo sapiens*) are the only animals that can walk in straight gait on two legs. However, even before this modern human, there were some primitive species of human beings who could walk on two legs. Research on evolution helps us understand that. We can realize our evolution from the wonderful presence and gradual expansion of fossils found in Africa, Asia and Europe. From the fossil records we can understand when we started walking upright. We can understand when we got the changes of our

shape such as the wide buttocks (back) of our body, the big toes compatible with the rest of the legs and the short arms. In the course of evolution, the size of our brain has also increased. The research so far says, humans existed on the African continent about 2,00,000 years ago. Among our familiar animals, monkeys, orangutans, and chimpanzees are the closest to the human species in terms of physical features. Humans and these animals are called primates.

All primates have a common feature and that is the presence of the spine in their body. When we touch our back with our hand, we can feel some pieces of bones along the middle. It is our spine.

When we look at our body we see eyes, ears, nose, head, skin or skin, nails etc. We also have our heart, liver, lungs, kidneys, pancreas etc inside our body. These are different organs of our body. Other animals we know, such as ducks, chickens, cows also have these organs.

We can see our nails with bare eyes. When the fingernails are big, we cut them off. If we continue to cut these nails into small pieces, at some point, these pieces will no longer be visible to the bare eyes. Then we have to look at them with a microscope. Through the microscope we can finally see the cells of the nail. We have already learned that cells are the unit of our structure and function. Complex organisms like humans need billions of cells. These cells combine with each other to form the structure of humans like us.

Scientists discuss these matters from microscopic cells to the visible structure of the human body following the below steps:

Cell > Tissue > Organ > System

The cell is the lowest of the stages or we can say the simplest unit of this formation.

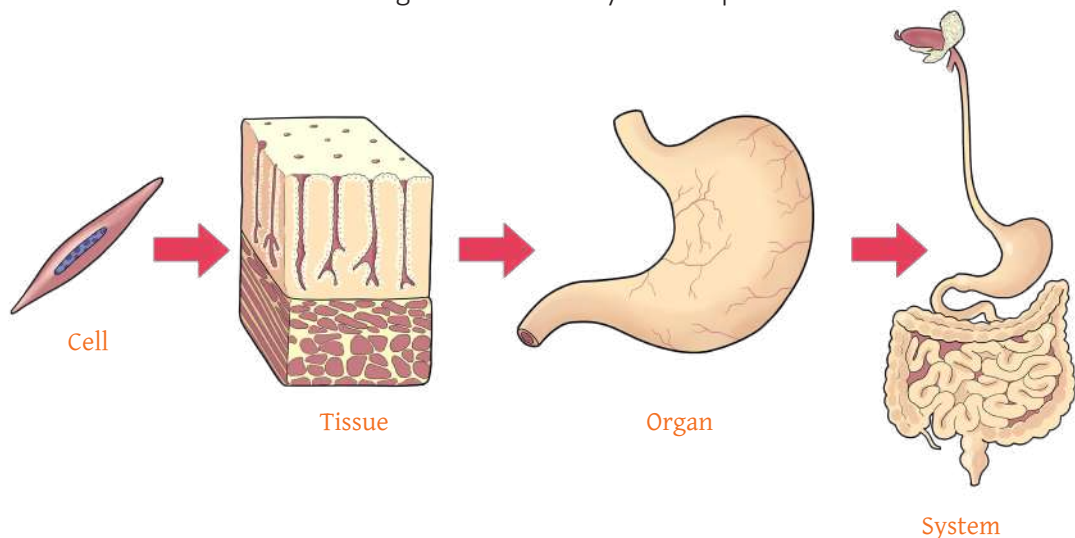

System is the highest stage of this formation.

We will discuss these topics below.

Cell

How many cells are there in the body of an adult human?

Scientists have been asking this question for a long time. According to the latest data, this number is around 30-40 trillion (30000000-40000000 crore). These billions of cells play a role in the growth, metabolism, stimulation and reproduction of the human body.

The general characteristics of animal cells that have been discussed in Chapter 3 are also applicable to human cells.

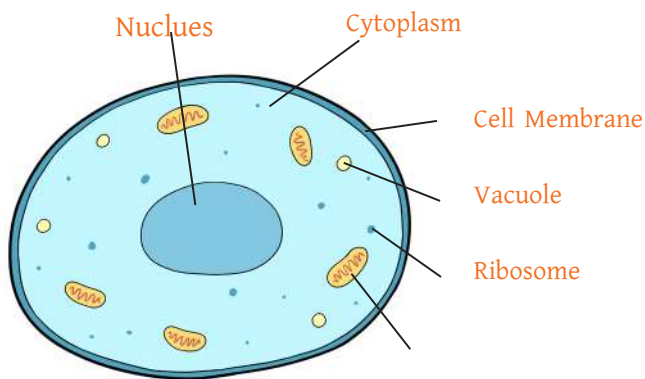
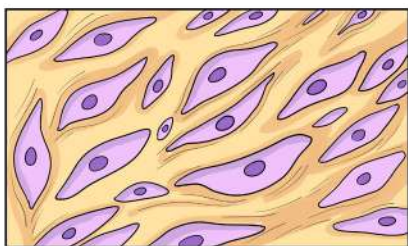

Image: Animal cell

Tissue

There are different types of cells in the human body. They can be divided into four basic classes. The special structural units that these four types of cells create in combination with the elements around them are called tissue. The tissues of the human body can be divided into four types based on four classes of cells.

Type-1: This type of tissue covers the outer covering of our body and the outer layer



Connective Tissue

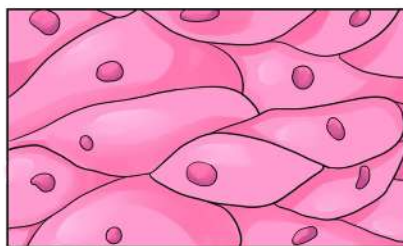

Epithelial Tissue

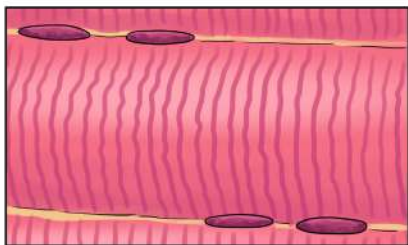

Muscle Tissue

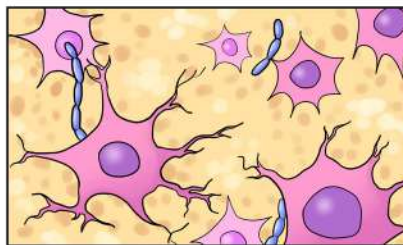

Nerve Tissue

of our internal organs and the body cavities. They are called epithelial tissue.

Type-2: This type of tissue is able to contract and expand and they build up muscles in the body. They are called muscle tissue.

Type-3: This type of tissue regulates the sensitivity of our body and builds up the nervous system. They are called nerve tissue.

Type-4: These tissues connect the distant cells directly or indirectly, and integrate the structure of the body. They are called connective tissue.

Organ

The four types of tissues mentioned above combinedly form different parts of the human body. An organ is a combination of multiple tissues that form a unique structural and functional unit. There are different organs in the human body. These organs are important for our growth and survival. For example, heart, liver, lungs, kidneys, etc. are organs of our body. Our skin is the largest organ of the human body.

System

Different parts of our body do not work differently or separately. Rather, some of them work together in the same way in our body. These organs can be divided into several parts on the basis of their function. Each part is called a system. For example, our heart is an organ. Its structure is made up of the four types of tissues mentioned above. The function of this organ is to play a role in the circulation of blood throughout our body. However, the heart alone cannot perform this function of blood circulation. For this task, it has to work through an integrated system consisting of blood vessels. This whole system is called the circulation system. Thus, the various organs of our body whose names we know such as kidney, liver, lungs, eyes, nose and other organs depend on other organs and tissues for their function.

Below we will get a brief overview of the major systems of the human body.

1. Integumentary system: Sometimes, bleeding occurs when the skin on the hands and feet is bruised while playing or in an accident. The skin covering our entire body forms a covering or protective wall in our body against the outside world and protects our body. The system formed by this skin of our body is the integumentary system. The integumentary system protects the body from being attacked by harmful microorganisms and chemicals.

2. Muscular and skeletal systems: When we walk or drink a glass of water, the bones of our body and its associated muscles bear the burden of these functions and give the necessary transmission energy. The system jointly formed by the bones or skeleton of our body and muscles together is called the musculoskeletal system. It is often referred to separately as the muscular and skeletal systems. The skeletal system of the human body consists of about 206 bones. The combination of muscle system

and the skeletal system helps the body to move and protects the body's internal organs.

3. Respiratory system: We cannot live without respiration. Our lungs, along with other organs, are working to control our respiration properly. The respiratory system is made up of our body's respiratory tract, lungs and respiratory muscles. The respiratory system receives oxygen from the air, and releases carbon dioxide into the air.

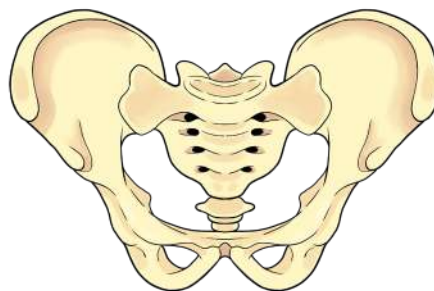

Image: Bones

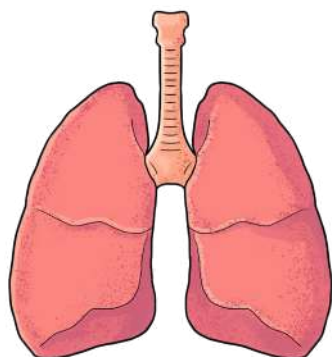

Image: Lungs

4. Vascular system:

We have an efficient transportation system made up of blood for communication among different parts of our body. The heart delivers blood to the body, supplies oxygen and nutrients to the various organs and cells of the body through the blood vessels and transports the waste products created in those places. The vascular system is made up of this heart, blood and blood vessels and capillaries.

This vascular system controls the delivery of nutrients to different parts of the body, as well as the collection of waste and the fact that our body temperature remains the same all the time (without fever).

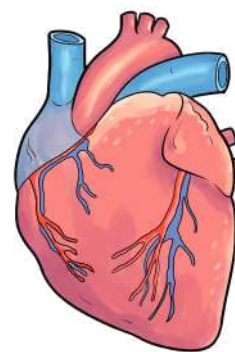

Image: Heart

5. Digestive system: We all eat food when we are hungry. This food does not directly benefit our body. Our digestive system derives energy and other nutrients from food and makes it useful for the body to function. The digestive system is made up of the mouth, esophagus, stomach, small intestine and large intestine. This system converts the food we consume into usable nutrients, which are then absorbed by our body. The last part of this system is the anus, which acts as a way to release unusable parts or wastes of our food from our body.

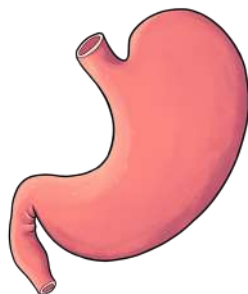
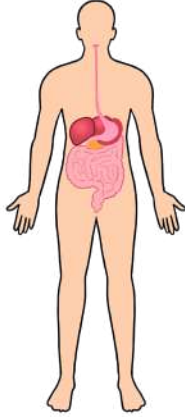

Image: Stomach

6. Renal system: Our renal system works to ensure that liquid waste or urine can pass out of our body. It is basically made up of organs like our kidney, ureter and bladder. This system produces urine and thereby removes harmful nitrogen



Skeletal System



Digestive System



Muscular System

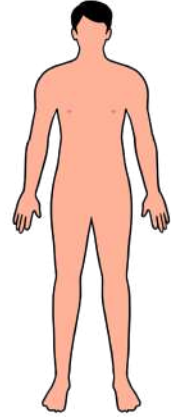

Integumentary System

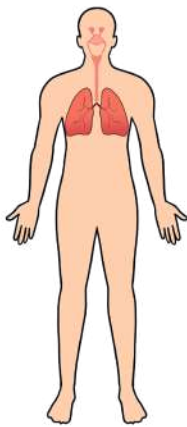

Respiratory System

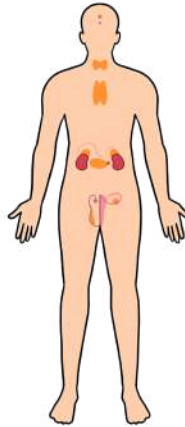

Endocrine System

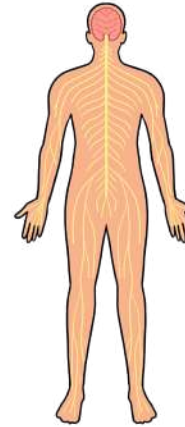

Nervous System

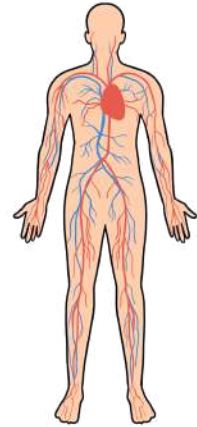

Vascular System

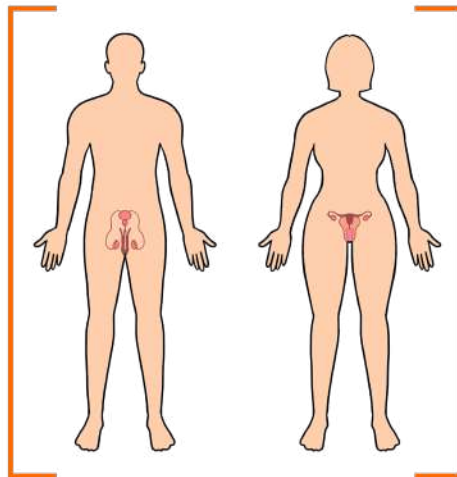

Male (left) and female (right) Reproductive Systems

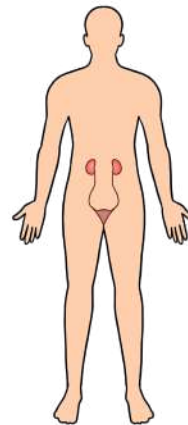

Renal System

Image: Major systems of human body

compounds and other wastes from the blood.

7. Nervous system: We can think, we can make decisions, we can respond to other's call, we can feel cold and heat. This is possible because of our nervous system. Our nervous system is made up of our brain, spinal cord, and the nerve-connections that are spread throughout our body. When we touch something hot, we instantly remove our hands. What actually happens then? The information that the thing is hot is transmitted to our brain by the nerve fibers in the skin of our hand through the spinal cord in the backbone.

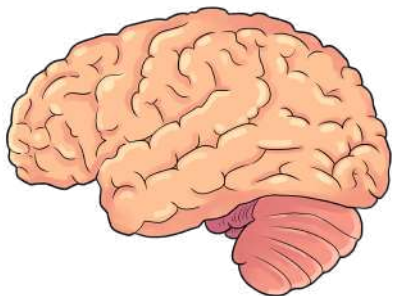

Image: Brain

The job of the brain is to analyze this information and create the impulse to feel and respond. That's, in this case, the brain not only creates a feeling of warmth in the skin of our hand, but also instructs us to remove the hand immediately.

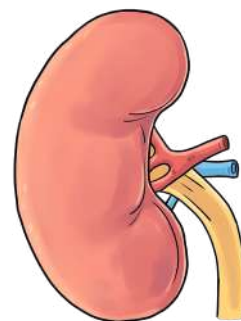

Image: Kidney

8. Endocrine system: Our body discharges some biochemicals from different parts for different functions. Some of them are made in one part of the body, but then they go to different parts of the body and perform their work. Such substances are called hormones. These hormones are made up of glands in different parts of the body, and these glands combine to form endocrine system. This system acts as a network of chemical interactions to coordinate various processes in the body.

9. Reproductive system: Like all other living beings, we have the reproductive system in our body to ensure population growth and continuity of the human species through it. Some parts of this system are seen as external organs which are different in the males and females, such as, penis and scrotum in boys, and vagina in girls. However, we can't see the important parts of the reproductive system which are situated inside the body. For example, testicles, prostate, urethra, etc. in boys, and ovaries, uterus, etc. in girls. These internal organs of the reproductive system produce our reproductive cells, such as sperm and ova.

Adolescence

One of the most important characteristics of all living things is their physical growth and preparing themselves for procreating.

When we sow seeds of any crop in the field, shoots sprout from the seeds, then they grow slowly. At one stage the tree flowers again, and new seeds are formed there. This is how the creatures in nature prepare themselves to create new generations as they grow.

The same is true in case of the human species as well. When we look around, we see small children, then we see young people who are older than they. Our parents are adult people. Again, our body grows step by step. It is only after the birth of new children in our family or relatives that we see them grow up in front of our eyes. But this process of human birth begins much earlier in the mother's womb. We will learn more about that in higher classes.

But after the birth of children, due to their physical growth they reach the adolescence at a stage. As you are in class six, now you are in the adolescence. At one time you were children. Your bodies are constantly growing. This growth of the body is not only growing in our height, but all the organs of our body are growing. The heart inside our chest (part of the circulatory system), the brain inside the head (part of the nervous system) or the kidneys inside the stomach (part of the excretory system)- these are all growing in harmony with our growing body.

When we reach a certain level of age, the visible organs of our body's reproductive system also begin to grow. These organs show their separate characteristics for boys and girls. Soon we will learn about those changes. But before that, it is necessary to say that we get new feelings about these reproductive organs as a result of various changes inside our body. Earlier, in the discussion of systems, we have become acquainted with the endocrine glands. These glands discharge a special chemical signaling substance which we commonly call 'Hormone'.

At one stage of adolescence, certain hormones begin to form in the body of men and women. These hormones are called sex hormones or sex-based hormones because they differ from male body to female body. We become aware of our external reproductive organs mainly due to the new interactions of these sex hormones with our brain.

So, you must have understood that with the change in your body, there is a change in your mind as well as brain, which leads you to the reproduction or maturity of biological features. This reproduction or biological maturity is usually achieved in humans after the age of 16-18. But the journey to that maturity begins even earlier, between 11-13 years for boys and 9-11 years for girls. This is the age when, we begin the journey towards maturity about reproduction as human beings. This age is our adolescence. This period is called adolescence as the journey from our childhood (8-9

years from birth) to adolescence (after 18 years) begins in these 9-13 years. Changes in body and mind during adolescence are normal human characteristics as a being. It is also important to note that visible changes in the reproductive organs of the human body, which begin at adolescence, continue for several more years. At the same time the feeling also changes during this time and the sex hormones created in the body work behind all these things.

Physical changes in boys during adolescence

Changes in the body development and body shape of boys continue for a long time. These changes begin from adolescence and continue till 30 years or above. There are many changes that begin by the end of adolescence. Below are some changes during adolescence, which you can notice in your own body.

Changes in the tone of voice: Surprising to hear, it is no overstatement to say that we actually hear an important primary feature of boys' adolescence. And that is the change in the tone of their voices. During adolescence, the tone of boys' voice is deeper than in childhood, which indicates other changes in their body.

Being well-formed in body structure: In the case of boys, a special sign of adolescence is that different parts of the body continue to be strong and well-formed. These parts include chest, back, waist, buttocks, thighs and legs. This physical development starts from adolescence to the age of 30 years. Basically, during this time, the muscles of different parts of the body of the boys are well formed.

Changes and increase of bone structure: From adolescence onwards, boys' bone structure increases and at the same time the bone gains a stronger structure. Bones of many parts of the body becomes wider. This change begins from adolescence and may continue till 30 years or above.

Change of penis and testis: One of the most important changes in boys during the adolescence is the shape of their penis and testis. A common function of the penis is to make a way for discharging urine from the body through the urethra. But another of its function is to play a role in reproduction. The penis gets ready for reproductive function during adolescence. The size of the penis gets bigger during this time. The



flow of blood and oxygen in the penis increases with the influence of sex hormone. As a result, sometimes the penis hardens. This increase and change of the penis continue up to 18 years. The testis also changes along with the penis. Sperm required for reproduction is produced and stored in the testis.

Partially active sperm is noticed among boys in 13 years, but full activeness does not come before 14-16 years. However, this process is completed among some very fast. Hair in different parts of body: The very common sign of adolescence among boys is the presence of hair in different parts of their body and gradually the hair becomes thicker. Such an important change comes through the presence of hair in the root of penis. This hair is called pubic hair. The part of the buttocks beginning from the upper portion of the thigh to a certain portion of the upper abdomen is called the pelvis. This pubic hair is usually seen some days after the penis starts to increase. This hair spreads to upper parts after the adolescence.

The spread of this hair in the body mainly increases under the influence of male-specific androgen hormones. For example, under the nose of the upper lip, a sign of moustache is formed at this time. Besides, armpit hair, beard, the presence of hair in the chest, etc. areas are gradually seen.

Physical changes in girls

Increase of body size, fat: During adolescence, growth of fatty tissue occurs in more parts of the body of girls than boys.

The most common areas of the female body that sees the presence of fatty tissue include the mammary glands, half lower parts, thighs, upper arms, and buttock regions. Among these, the most fat is usually stored in the mammary glands. A ten-year-old girl has only 5% more body fat than a boy of the same age. But by the end of adolescence, this difference is close to 50%.

Presence of hair in different parts of body: During adolescence, the presence of hair in some parts of the body is also seen in girls like in boys. Among these, pubic hair is the most common sign of adolescence. Initially, thin and short hair exists around and above the vagina only but gradually the density and spread of this hair increase. This growth continues even after puberty.

Hair is found on the hands, feet, armpits and thighs, especially in girls. It is usually between 14-16 years. Many girls also have light hair on their faces. Breast enlargement: In girls, usually a hard and soft lump is seen below the nipple of one or both breasts as the first sign of adolescence. This happens at an average age of 10.5 years. Within the next 6-12 months, the breasts become soft and swollen on both sides. This is mainly due to the accumulation of fat in the breast area. This

growth continues even after adolescence.

Changes in vagina, uterus and ovaries: Increased discharge of the hormone estrogen in girls results in changes in the structure and function of their vaginas, uterus, and ovaries. These changes may not be visible to the bare eyes because these organs are inside the body. But for the effect of estrogen, at first, white fluid leaks through the vagina, which is known as leukorrhea (also spelled leucorrhoea).

Menstrual cycle: Usually two years after the beginning of whitish fluid discharge (leukorrhea), blood discharge starts through the vagina at a certain time of the month. This is called menstruation or period. The average age of menstruation among girls in Bangladesh is considered to be 9-13 years. This incident is called menstruation because the bleeding occurs at certain times of the month at regular intervals (the word menstruation means bleeding). The beginning of menstruation is an important stage in the adolescence of girls. This is a definite signal on the way to their preparation for reproduction.

Body care

We need regular care to keep our body healthy. During the COVID pandemic, we realized that cleanliness of the body and some general hygiene can save us from diseases. We need general cleanliness. At the same time, we can ensure regular growth of the body and make for the loss through regular intake of nutritious food. Some of our common habits help us to maintain good health, such as,

- ☑ Taking regular baths
- ☑ Trimming nails and hair
- ☑ Washing hands with soap before and after meals and after using the toilet
- ☑ Not spitting and coughing everywhere
- ☑ Covering nose and mouth with a handkerchief or tissue or elbow when sneezing and coughing

These practices and habits help us to maintain our own health and health for the people around us as well.

We have different cares for different parts of our body. It is important for us to take care of the part our body that remains uncovered as well as the part that is covered. We need to keep all our organs clean. Bacterial infections can be caused by the accumulation of sweat and dirt on certain parts of our body. These parts need to be cleaned with soap during the bath.

While selecting food, we need to make sure that we choose a balanced diet consciously. The food that tastes good to the mouth may not be good for our body. We need to focus on nutritious food for a healthy body. In addition, regular and timely

sleep should be practiced. We need about 8 hours of sleep a day for a healthy body. We have to try to sleep between 9-10 pm. We have to wake up very early in the morning and engage ourselves in daily work.

Another important factor of our hygiene is regular exercise. From time to time we have to do physical exercise with our friends. These habits and lifestyles will help keep our body and mind healthy.



The

human body is regulated by many complex chemical processes. We do not consciously control everything. Even without our knowledge, the body continues to carry out its essential functions, which are vital for our life. However, if we consciously take proper care, eat the right food, do physical exercise regularly our body will be healthy, strong and functional. So, we have to be watchful about these things.

Exercise



1. Do you see any similarities in the information in the book with the physical and mental changes that happened or are happening in you during adolescence?
2. What habit do you want to change for your physical and mental care?

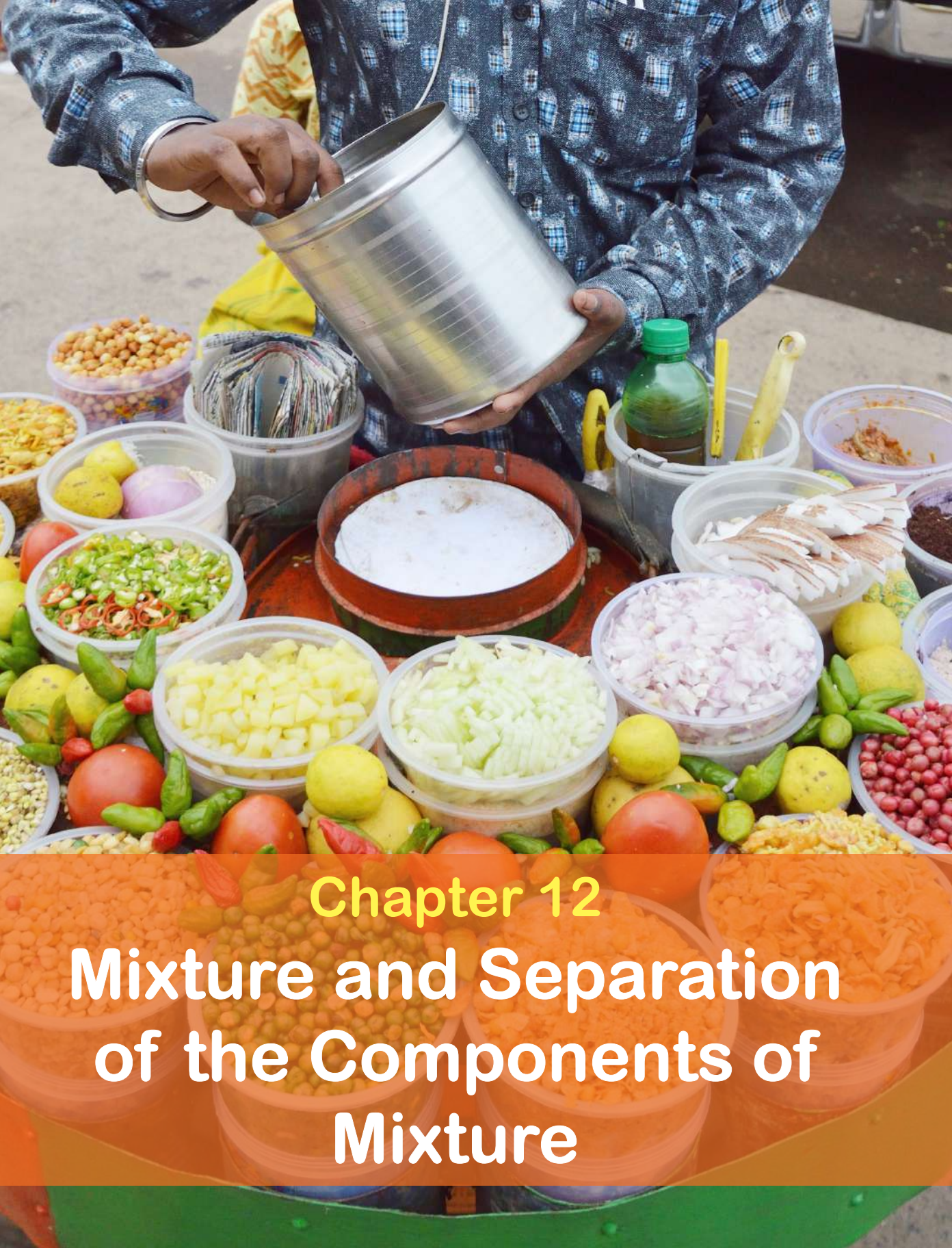

Chapter 12

Mixture and Separation of the Components of Mixture

Chapter 12

Mixture and Separation of the Components of Mixture

At the end of this chapter, students will be able to know the following:

- ☑ Solutions, Solvents and Solutes
- ☑ Water and the water cycle
- ☑ Aqueous solution
- ☑ Waterless solution
- ☑ Liquid and gas solutions
- ☑ Solutions of solid and solid substances
- ☑ Colloid and Suspension
- ☑ Different methods of separating the components of mixture

All of you are familiar with the word 'mixture'. When two or more substances are mixed with one another, that state of mixing is called mixture. For example, sugar syrup is a mixture of sugar and water, 'Panch phoron' is a mixture of five kinds of spices, air is basically a mixture of oxygen and nitrogen, or brass is a mixture of copper and zinc. As you can see, it is possible to mix everything solid, liquid or gas.

Mixtures are generally of two types: homogeneous and heterogeneous.

1. In a homogeneous mixture, the particles are mixed evenly with each other. That is, there are no more or no less particles anywhere. Air is an example of a homogeneous mixture.
2. In heterogeneous mixtures, the particles do not remain evenly mixed. Somewhere there is more or less number of particles, and they are different from each other. So the particles of the mixture can be clearly identified. For example, 'Panch phoron'.

In this chapter, we will learn about three special types of mixtures called solutions, suspensions and colloids.

Solutions, Solvents and Solutes

When you drop a granule of sugar in water, it dissolves there. Water separates the small particles of sugar, then, the sugar particles are spread all over the water. We say that sugar has dissolved in water and they have combined to form a solution.

A solution is formed when two substances combine perfectly with each other to form a homogeneous mixture. The substance that dissolves another substance, that is, one which is more in quantity, is called a solvent. The substance which dissolves in another substance, that is, one which is less in quantity, is called a solute. (Here,

water is solvent and sugar is solute.) All of the states-solid, liquid and gas can combine with each other to form a solution. The important thing about a solution is that its constituents do not react chemically with each other, so they can be separated physically.

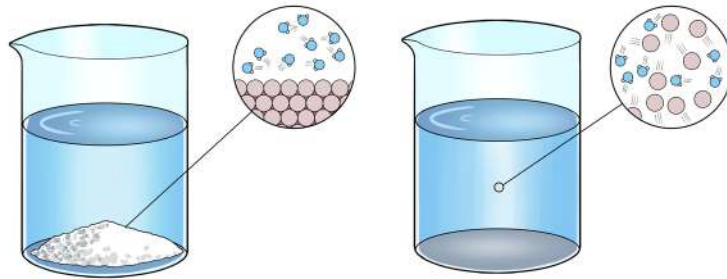

Image: Solution of sugar and water. It shows how sugar and water remain in solution.

Do you know that the sea is the largest solution in the world? The seas and oceans occupy 70% of the earth's surface. The sea water is solvent, but you can't drink sea water. This is because many types of matters/substances are dissolved in seawater as solutes

Water and Water Cycle

Water usually remains in liquid form, but it is also found in solid and gaseous states. You know that the solid state of water is called ice and vapour is the gaseous state of water.

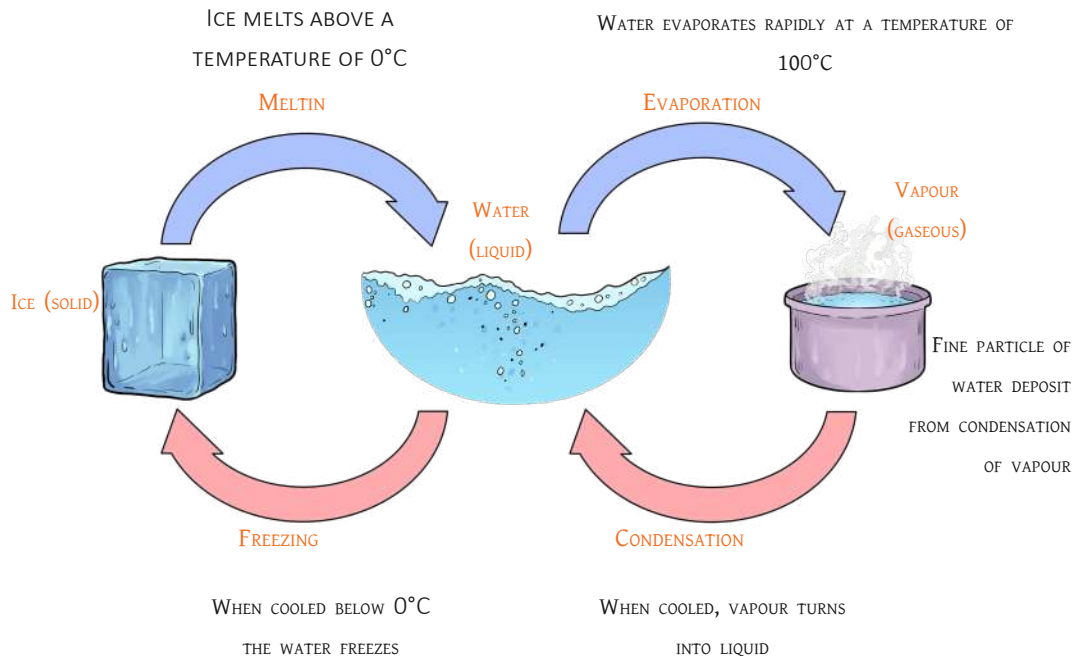

Image: Different states of water

0°C is the melting point of ice, at the same time it is the freezing point of water which means at this temperature water turns to ice! The boiling point of water is 100°C, which means that when water is boiled to 100°C, it evaporates instantly.

Melting, boiling, evaporation and condensation play important roles in the water cycle, meaning that this cycle is repeated. Despite the fact that a large amount of water evaporates from the sea every day at normal temperature, the sea level does not decrease. The reason is that the evaporated water condenses and turns into rain, the rain water flows into the river and falls back into the sea. In this way the water cycle continues.

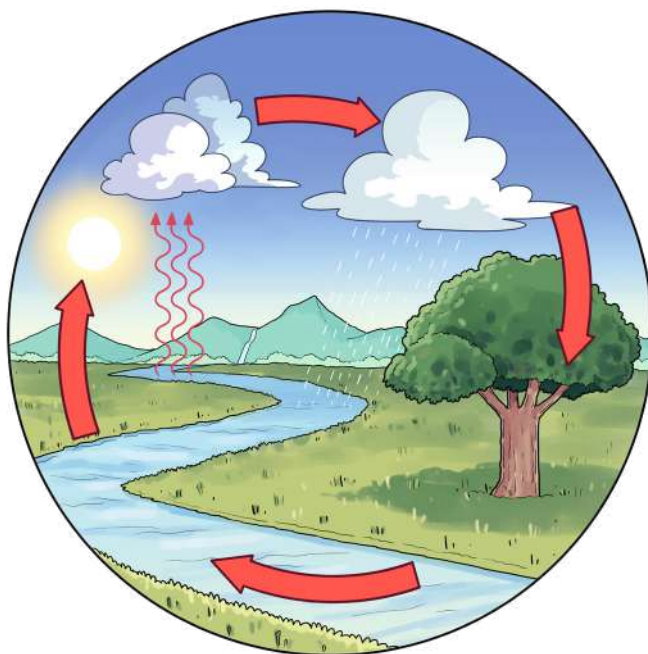

Image: The water cycle

Aqueous solution

Solutions where water is used as solvent like the solution of sugar and water are called aqueous solution. But water is not used as a solvent in all solutions. In addition to water, a number of chemical substances such as acetone, alcohol and ether are also used as solvents.

Concentration of solution: Dilute and concentrated solution

The concentration of the solution is determined by the amount of solvent dissolved in the solution. In order to understand this, we can try to make dilute and concentrated solutions of different concentrations.

Solutions of different concentrations



Take a cup of drinking water in each of two clear glasses. Now, mix one teaspoon of sugar in the first glass and three teaspoons of sugar in the second glass, and stir the water very well so that the sugar is completely dissolved. Now take one teaspoon of sugar solution from each of two glasses and measure its sweetness.

(Caution: In this case, sugar solution is safe for our body. But most of the chemicals are harmful to our body. Therefore, it is strictly forbidden to eat or

drink any kind of chemicals and solutions without knowing it properly.)

You will see that the solution in the glass in which 3 teaspoons of sugar was mixed would be sweeter to eat. Although the volume of the two solutions is same, the solution containing 1 teaspoon of solute (sugar) is dilute and the solution containing three teaspoons of sugar is a relatively concentrated solution.

We can do a different test this time. Suppose there is 1 teaspoon of sugar in each of two cups of water, then the concentration of the two solutions is equal. This time if you pour or add another cup of water in a glass and shake it well, you will see that the one which has less water will be sweeter. In this case also, it has been possible to make concentrated and dilute solution, this time keeping the amount of solute same, the amount of solvent has been increased or decreased.

So you have seen that just as the solutions of different concentrations can be made by decreasing or increasing the amount of solute; in the same way, dilute and concentrated solutions can be made by keeping the amount of solute unchanged and by increasing or decreasing the amount of the solvent.

Here we have measured the sweetness and estimated the diluteness and concentration of the solution. If we made a solution of different concentrations in the same way by using deep blue (tunte) or copper sulphate instead of sugar, then we would see that the colour of the dilute solution is lighter and the color of the concentrated solution is deeper.

Saturated and unsaturated solutions



You can try the following experiments to differentiate

between saturated and unsaturated solutions. To do this test, take a cup of water in a glass like before. Now add a little more salt in a glass of water and keep stirring properly. In the beginning, the salt is being completely mixed, but at one time, even if you stir it very well, it is not being mixed or dissolved.

UNSATURATED SOLUTION:
IT WILL DISSOLVE EVEN IF
MORE SOLUTE IS ADDED.



SATURATED SOLUTION: IT WILL NOT
DISSOLVE, EVEN IF MORE SOLUTE IS
ADDED.

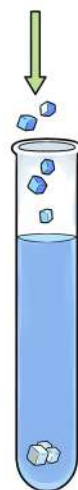

THE SOLUTE IS
ACCUMULATED AS
RESIDUE.

Once the salt was getting dissolved, but why is it not being dissolved anymore? This is because, once the salt was getting dissolved, the solvent's capacity with solute has been fully filled. In this condition, solvent (water) can no longer dissolve any other solute (salt). Thus, at a certain temperature, if the holding capacity of a solvent in a certain amount of solvent is filled by solute, then that solution is called saturated solution. On the other hand, if the amount of solute dissolved at a certain temperature is less than the maximum holding capacity of the solvent, then it is called unsaturated solution.

In the above experiment, the solution was unsaturated until the salt residue has accumulated.

When the solution becomes saturated, it accumulates as residue, since it can no longer dissolve the solute. No matter how much you stir it, it will not be able to dissolve any more solute.

It is to be mentioned that if the temperature of a saturated solution is increased, it can again dissolve the excess solute. If you wish, you can test this matter. Can you guess the reason?

Universal solvent

In the meantime, you have known about the solvent. Universal solvent refers to a solvent that can dissolve all types of substances. Is it possible to get such a solvent at all? Definitely not. Of all the solvents that we know, water has the ability to dissolve relatively more substances than any other solvent. Therefore, water is the only universal solvent available so far. Water can dissolve many types of organic matters or substances (such as spirits, acetic acid) and many inorganic substances except calcium carbonate, silica etc. It can even dissolve many gases.

Waterless solution

You have known a little while ago that apart from water, solvents can also be made with other things. Honestly speaking, a lot of household items are such solutions. Here are some solutions where water was not used as solvent.

Tincture iodine is a disinfectant; it is kept in the first aid box for application in the form of dabbing over a cut or injury. Although iodine is a disinfectant, it cannot be used directly. Because iodine is a solid substance, it cannot be applied directly. That is why iodine is used by dissolving it in alcohol. Alcohol is used as a solvent because alcohol can dissolve iodine much better than water. When the solution is applied on the bruise, it spreads evenly all over the place. Alcohol evaporates and iodine remains, which acts as a disinfectant. Solvents are often used in this way to disperse the solute.

Varnish is painted on the wood as a solution. A solid coating of solute remains on the

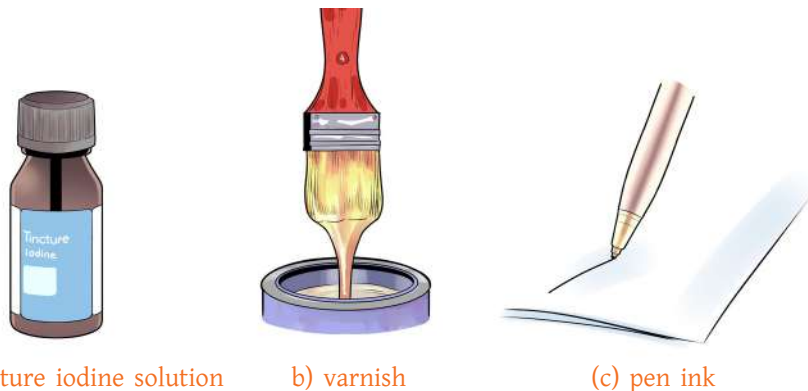

IMAGE: WATERLESS SOLUTION

wood as the solvent spirit evaporates.

Pen ink is a very fine mixture of different solvents. These solvents at the same time enable the ink to transmit and to dry easily.

Liquid and gas solutions

Now let us notice some solution where the solvent is liquid, and the solute is gaseous substance. Soft drinks are very familiar to us. As soon as the soft drink bottle is opened, the gaseous substance comes out in the form of bubbles. This gas is carbon-di-oxide which is dissolved in a soft drink in a liquid state. So, we can say that soft drink is an example of liquid-gas solution.

Solutions of solid and solid substances

Just as solutions can be made with solids and liquids, in the same way solutions are also possible from solids with solids. You have already known that brass is a solution of copper and zinc, just as bronze is a solution of copper and tin. Various types of metal alloys with solutions of aluminum, nickel or titanium are used to make rockets or planes.

Preparation of crystals from solution

Have you heard the name of crystal? Crystal is a solid substance in which the molecules are arranged precisely. Examples of crystals are table salt (sodium chloride), blue vitriol or copper sulphate. You know that copper sulphate is blue in color. This blue copper sulphate is very soluble in water. Very nice blue crystals of copper sulphate can be made. For that, you have to collect a little amount of copper sulphate from the market first. But remember that it is toxic to plants or animals, so it or its solution should not go into anyone's mouth.

To make the crystal, you have to make a saturated solution of copper sulphate in high

ANOTHER 36 GRAMS OF COPPER SULPHATE WILL DISSOLVE

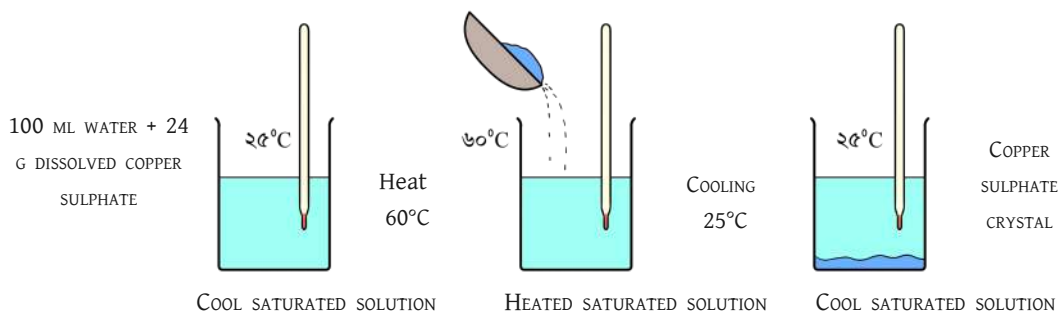

IMAGE: CRYSTAL SEPERATION FROM SOLUTION

temperature water in a container with the help of your teacher or guardian. Then this saturated solution should be left in a safe place. If you can leave the solution for a few days without touching it, then you will see that a crystal of copper sulphate has been formed there.

Suspension

If you leave some mixtures for some time, their compounds get separated from each other. These mixtures are called suspensions. The mixture of chalk powder and water is an example of suspension. It looks like milk. Unlike in a solution in a suspension, the components do not mix with each other themselves. For example, if water mixed chalk powder is stirred or shaken, it is mixed fully in water. When stirring or shaking is stopped, it gradually settles down again at the bottom and separates from the water. You must have seen the same thing happen in the case of the muddy water of a pond or river. If you leave turbid water in a bottle without stirring it, the particles of the mud will settle down at the bottom. If you wish, you can make suspension by adding sand in a bottle of water. Shake it and notice the movement of the particles. Then if it is left in a static state, in a short while the particles of sand will go to the bottom of the bottle and accumulate. Some fine particles stay in suspension form for a very long time. The characteristic of suspension is that the particles can be easily separated from the suspension by the filtration process.

You must have noticed a writing on some of the sauce bottles or medicine bottles, “Shake well before use”. Because those are actually suspension type solutions.

Colloid

We have seen that for the case of suspension particles of floating solute, if kept still for a while, they accumulate at the bottom of the vessel. You may have noticed that if the particles are very fine, then it takes a long time for them to settle down. So naturally the question arises in our minds, can the particles be so fine that if left in a static state it will never accumulate as residue? It can actually be like that, and such a mixture is called colloid. That is to say, a colloid is a mixture of nature in which the particles of a mixed substance can always be kept floating or in a mixed state without constant stirring or shaking. Even if you keep it stable for a long time, it will not separate and settle down at the bottom.

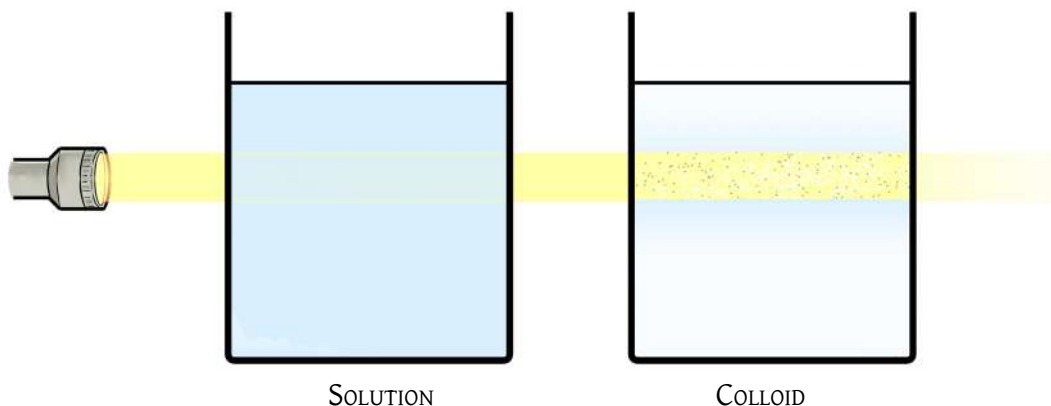

IMAGE: DIFFERENTIATION OF SOLUTION AND COLLOID WITH THE HELP OF LIGHT RAYS

Although the elements of colloid do not dissolve with each other, they blend perfectly with each other. Our familiar milk is an example of colloid which is made up of fine particles of water and fat.

Now we can talk about an experiment to differentiate between colloid and a real solution. When light goes through a real solution, the light will not be visible. But when it passes through the colloid, the ray of the light can be seen inside the mixture as the ray of light will scatter through the fine particles of the colloid.

Fog is another example of colloid like milk, where particles of water are scattered in the air. Again, the liquid pesticide 'aerosol' is a type of colloid where the insect resistant fluid floats in the air.

The size of the colloidal particles has to be less than 1 micrometre (one thousandth of a millimetre); if it is more than that, it becomes a suspension.

Separation of mixtures

Different methods of separating the components of mixture

A mixture may contain some kind of pollutant along with a pure substance, and sometimes we need to separate that pure substance from it. Sometimes it is necessary to separate a certain component of the mixture. There are different methods of this separation, such as evaporation, crystallization, distillation, etc. How these methods can be used properly is discussed below:

Filtration

Filtration method is used to separate the particles of insoluble solids from the solution. We are all familiar with the filtering method, we use the filter to separate the tea leaves from the tea. We use filter paper if we need to separate something more subtle. In this method, the filter paper is placed in a funnel, the solution is poured, and water or liquid solvent is allowed to pass through the paper. (See the image below).

Different types of filter papers are used to separate different sizes of solid pollutants from solutions. Depending on the size of the pollutant, the size of the pore in the filter paper is to be smaller or larger. Even in our homes we use filtration systems of different sizes and pores for different purposes.

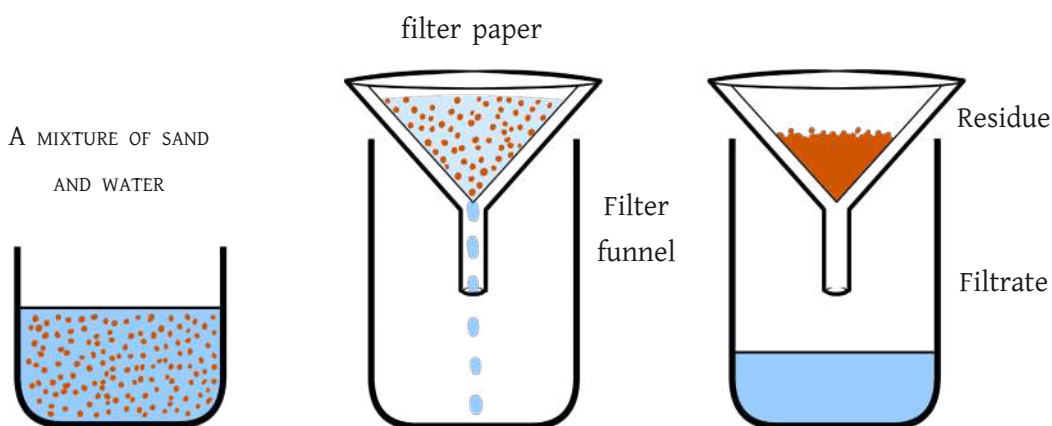

Image: Filtration method

Evaporation

Evaporation is a common method of separating a solute from a solution. Pure water evaporates at 100 degrees Celsius, but if there is something else dissolved there, the evaporation temperature may rise. If there is any impurity in the solution, it is first sieved through a sieve and then separated. The water is then heated to evaporate and separate the pure solute. However, even if heat is not applied, water evaporates in the normal process. When water is kept in an open pot, it dries up at one time. The wider the surface of the water or the higher the flow of air on the water, the faster the water evaporates.

You have read about homogeneous mixture. Using the evaporation process, you will be able to prove that the solution is a homogeneous mixture. Mix some salt in a little water to make a salt solution. Then divide the solution evenly in two or three bowls. This time, if you evaporate the water from the solution in the bowls by heating, you will see the same amount of salt in each bowl. If you wish, you can weigh the empty bowls and bowls with salt to make sure that you get the exact amount of salt out of the differences between the empty bowls and bowls with salt.

Decantation: the separation method

The decantation method is used to separate non mixable liquid or liquid-solid mixtures, such as suspensions. The method of separating oil from water is an example of decantation. Another example is the separation of a mixture of sand and water. You can easily understand the method from the following two examples:

1. If you leave a mixture of liquids that does not mix with each other like

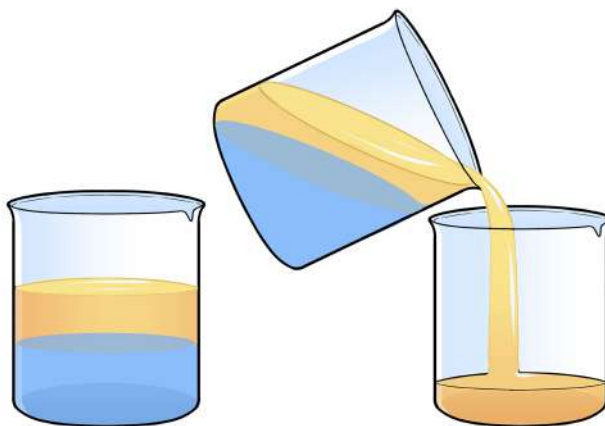

Image: Separation of water and oil by separation method (1)

water and oil, they are separated into two layers. Since oil is lighter than water, water remains below and oil floats above.

With the help of separating funnel in the laboratory, the water level can be moved from the bottom to another container, leaving only the oil layer there and then the oil can be collected in another pot. If you want to separate the oil from the water, you can carefully pour the oil into the pot from the top.

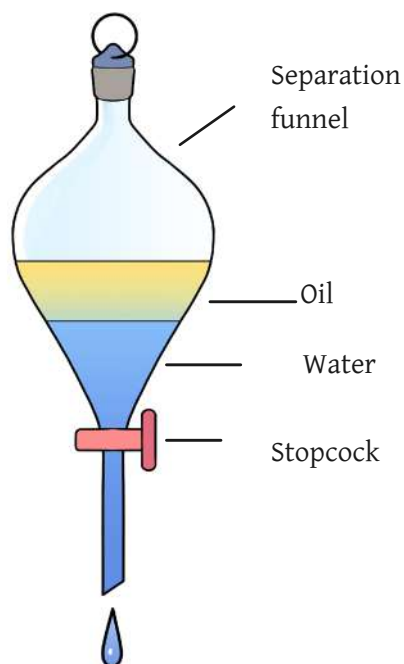

Image: Separation of water and oil by separation method (2)

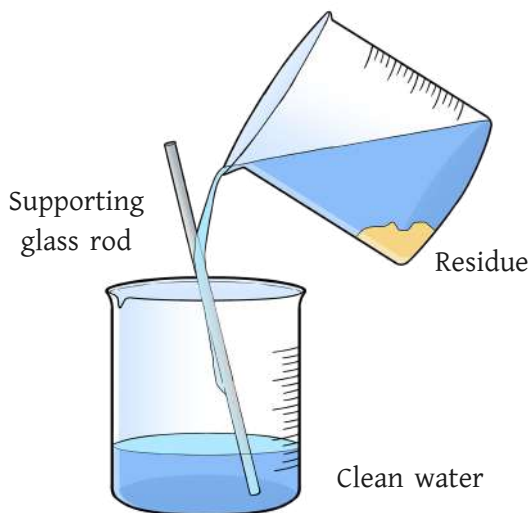
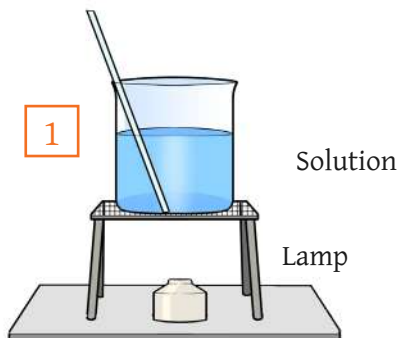
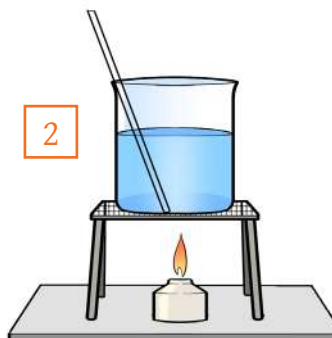

Image: Separation of sand and water by separation method

2. If you want to separate the mixture of water and sand in a decantation method, first let the sand settle down. Then carefully pour the clean water from the top into another container by touching a glass rod so that the sand or residue that has accumulated at the bottom does not move. When all the water on top has fallen off, only sand will remain at the bottom of the container.



Dissolved impure solids



Most solvents are being heated to remove.



Cooling the heated solution produces pure crystals.



The cold solution is poured to separate the crystals. It is then dried by pressing in a dry sheet or filter paper.

Image: Crystallization method

Crystallization

In the meantime you have learned how to make crystal. Since only the purest solute of a solution turns into crystal so, one method of purification of solids is crystallization. In this method, first the insoluble substance is separated by filtration method. When the solution is boiled in an open pot, the solvent begins to evaporate and the solutes begin to separate. When the solution is cooled, the solute particles gradually begin to solidify as crystals on the bottom of the pot. They are then collected and dried according to the characteristics of the generated solutes. The size of the crystal depends on how quickly the solution temperature is reduced. When the temperature is decreased rapidly, the size of the crystal becomes much smaller. Larger crystals are obtained by cooling slowly.

Distillation

Water from well-refined taps or tube wells is available in clean state where there are no floating or insoluble particles. But it is not 100% pure. When tube well or tap water is boiled and dried, a small amount of solids is often found on the bottom of the pot. This means that tap or tube well water contains some chemicals which are called dissolved salts.

Using the distillation method, it is possible to get 100% pure water as shown in the figure below. In the distillation method, the liquid is first evaporated by applying heat. Then kept at low temperature, the generated vapour is cooled by running it through a glass tube or pipe. The cooled vapour then condenses into liquid water. The liquid water produced is called distilled water.

It is possible to get pure water from sea water in this method, but it is very expensive.

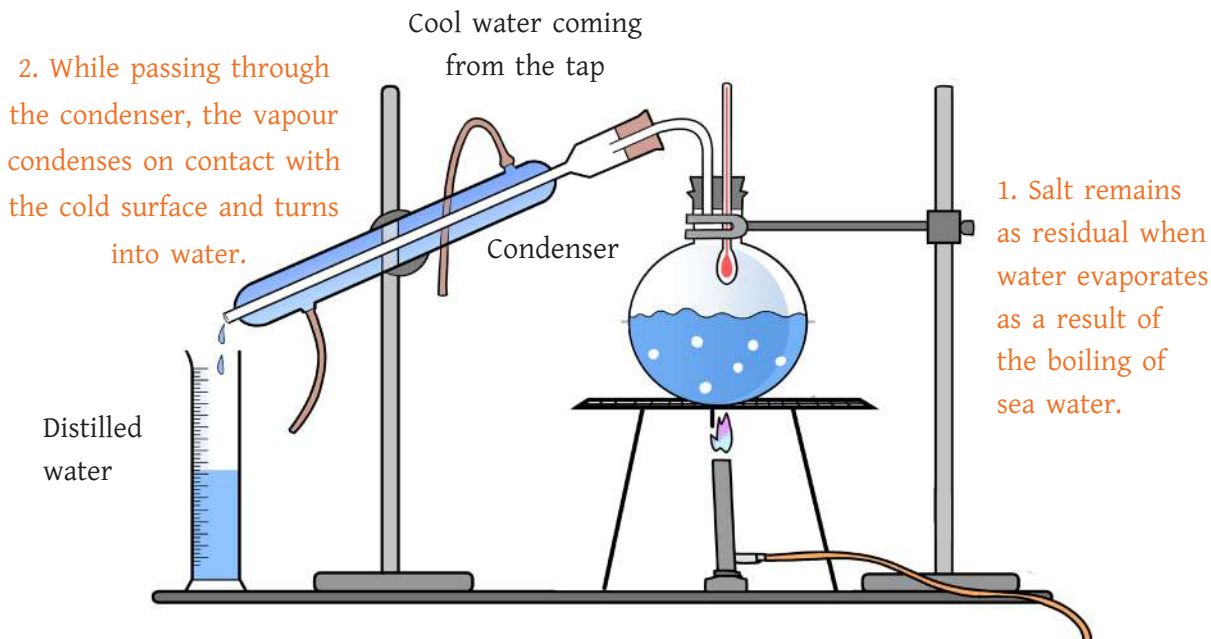

Image: Distillation method

Drinking water is not prepared from sea water in this method as it wastes a lot of energy.

Some of the mixture separation methods used at home

In our home, especially in the kitchen, we separate different types of mixtures in many ways. All kitchens have different types of sieves. To separate fine and large grains of food with a sieve is a common method. In our daily life, it is a regular thing to separate boiled rice from water or to separate tea leaves from tea with the help of a sieve. We often use thin cloth as a filter to filter the water. When the salt is high in the cooking of rural Bangla, the method of extracting it with charcoal is quite scientific. Many screw drivers have a bit of magnetism in their heads to distinguish the iron screw.

Will you be able to talk about other methods of separating the components of the mixture by observing the various activities of your home?



Image: Separation of tea leaves by sieve

Exercise



1. What kind of mixture is tea? Is it possible to separate the ingredients after making tea? If possible, how?
2. Prepare a mixture by mixing ata or flour with water. What can it be called? Solution, colloid, or suspension? Or none of these?



Chapter 13

Nutrition and Metabolism of the Organism

Chapter 13

Nutrition and Metabolism of the Organism

At the end of this chapter, students will be able to know the following:

- ☑ The process of food intake and digestion of microorganisms, plants and animals
- ☑ Growth and survival of plants
- ☑ Water and mineral transport system of plants
- ☑ Absorption and utilization of nutrients by animals

You must eat when you are hungry. If you do not eat for a long time, you feel weak. If you look around, you will see that all other animals are eating. Have you ever thought about plants? Do plants also need food? How do they get their food?

Not only plants or animals but also all organisms in nature need food to sustain and survive. The organism breaks down these foods and uses the nutrients in its cells. Organisms break down these foods and use the nutrients in their cells.

Nutrients are essential for the survival and growth of any organism. Simple organisms such as unicellular bacteria, yeasts or fungi receive nutrients almost directly from the environment. On the other hand, complex organisms, such as large plants or humans, collect and use nutrients in a detailed procedure.

But one thing applies to all of them- all organisms depend on their environment to meet their nutritional needs. Based on these characteristics, organisms can be basically divided into two groups- Autotrophic and Heterotrophic.

Organisms that can collect carbon, water, etc. from the environment to make their food are called autotrophic organisms. Such as- various microorganisms, green algae, plants etc.

On the other hand, organisms that collect their food (that is, various organic materials, such as protein, lipids or fats, carbohydrates) from other organisms in the environment are called heterotrophic organisms. Such as- different animals- humans, tigers, chickens etc.

This classification of organisms is based on the characteristics of how carbon-rich organic matter is formed. But again, if we consider how the organisms collect energy from the environment, the organism can be basically classified into two parts. Now we will know about that.

As the primary source of energy, some organisms use sunlight directly and produce

complex organic molecules (carbohydrates). These are called phototropic organisms. Such as- green plants and green algae, cyanobacteria etc. They produce carbohydrates in the process of photosynthesis in the presence of sunlight.

On the other hand, some organisms use chemical substances as a source of energy. These are called chemotropic organisms. Different bacteria, fungi are included in this type of life. We the humans are also chemotropic organisms. Because we can't also produce food directly by using sunlight. We meet our energy needs by eating ingredients from plants or other organisms. So far, we have been talking about nutrients that consist of a combination of carbon, hydrogen and oxygen. However, apart from these, some chemical substances are needed for the growth and survival of the organism. Such as- nitrogen, phosphorus, mineral salts (potassium, calcium, magnesium, sodium, iron, zinc, copper, manganese, etc.)

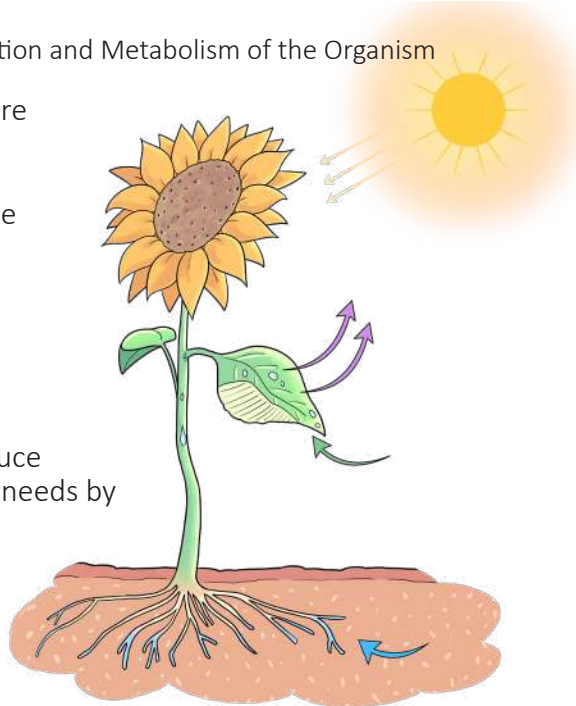

Absorption of nutrients by microorganisms

The absorption of nutrients by unicellular microorganisms is simple in nature. The cell is in direct contact with nutrients which make their nutrition relatively easy to receive. The nutrients very often enter the microbial cells through the cell membrane directly from the environment. Again, sometimes some of the carriers of the cell membrane help to take the nutrients from the environment into the cell.

The processes of receiving the nutrients by unicellular microorganisms are the principles that work for the case of multicellular large plants and animals.

Nutrition of Plants and Absorption

We usually think of plants as Autotrophic organisms. That is, they themselves make their own food. In fact, the matter is not entirely true. There are many plants that depend on other plants for their collection of nutrition. For example, the giant dodder (স্বর্ণলতা) - they have no chlorophyll. Chlorophyll is a type of green particle through which plants can make food. Due to the absence of chlorophyll in the giant dodder, they cannot make any food on their own in the process of photosynthesis. They depend on other plants for their nutrients. There are also plants that collect nutrition from insects- these are called insectivorous plants (পতঙ্গভুক). However, they can also produce their own food.

Plants have specific cells and tissues that are involved in transporting nutrients from the source place to different parts of the plant. These are called xylem and phloem tissues. We have already known about them before. These tissues can be compared to certain pathways inside the body of plants through which certain elements move. Xylem tissue carries water from the soil through the roots and absorbs the minerals dissolved in water. On the other hand, the nutrients (such as carbohydrates) made from the green leaves of plants reach to the other parts of the plant through a way, which is made up of phloem tissue.

Besides helping the plants in transporting nutrients, xylem and phloem also provide the strength of the plants. Microscopically the position of the phloem tissue around the xylem tissue can be seen.

Nutrition of Animals and Absorption

One of the major differences between plants and animals is in their food and nutrition management. No animal can produce food inside its own cells. As a result, animals have to depend on plants or any other organism or micro-organism for food. When we eat vegetables, rice, meat, fish, etc., we actually take in nutrients such as carbohydrate, proteins, fats, etc. Apart from this, we also need minerals like calcium, magnesium, sodium, vitamins etc. These ingredients also come from the various foods we eat.

We have seen earlier that plants have special tissues for absorbing and transporting their nutrients. In the case of animals too, their receiving nutrition and absorption are done through specific cells, tissues and organs. For example, human beings have digestive system. This digestive system breaks down the complex foods and uses cells to turn them into useful nutrients that are absorbed into the bloodstream and spread to other parts of the body.

The matter of food digestion starts from our mouth. When we eat rice, bread or fish, we cut them into small pieces by our teeth. The saliva secreted from the salivary glands under our tongue helps us digest food. Then the food goes to



our stomach. In the special environment there, the food is well digested. At the end of these steps, the food we eat breaks down into tiny organic molecules. In this stomach and its subsequent small intestine and large intestine, there are specialized endothelial cells (পরিশাষক কোষ) that absorb these tiny nutrients from the digested food and carry them throughout the body through the bloodstream.

Although there are fundamental differences among microorganisms, plants and animals, we see from the above discussion that there are some similarities among them. Although unicellular bacteria carry out all their metabolic functions in a single cell, the functions of multicellular plants and animals are carried out by different tissues and organs. However, the biochemical processes of each single cell in these tissues and organs have a fundamental relationship with the processes of unicellular organisms.

From this observation, it can be said that all living organisms have evolved on this earth based on some basic rules.

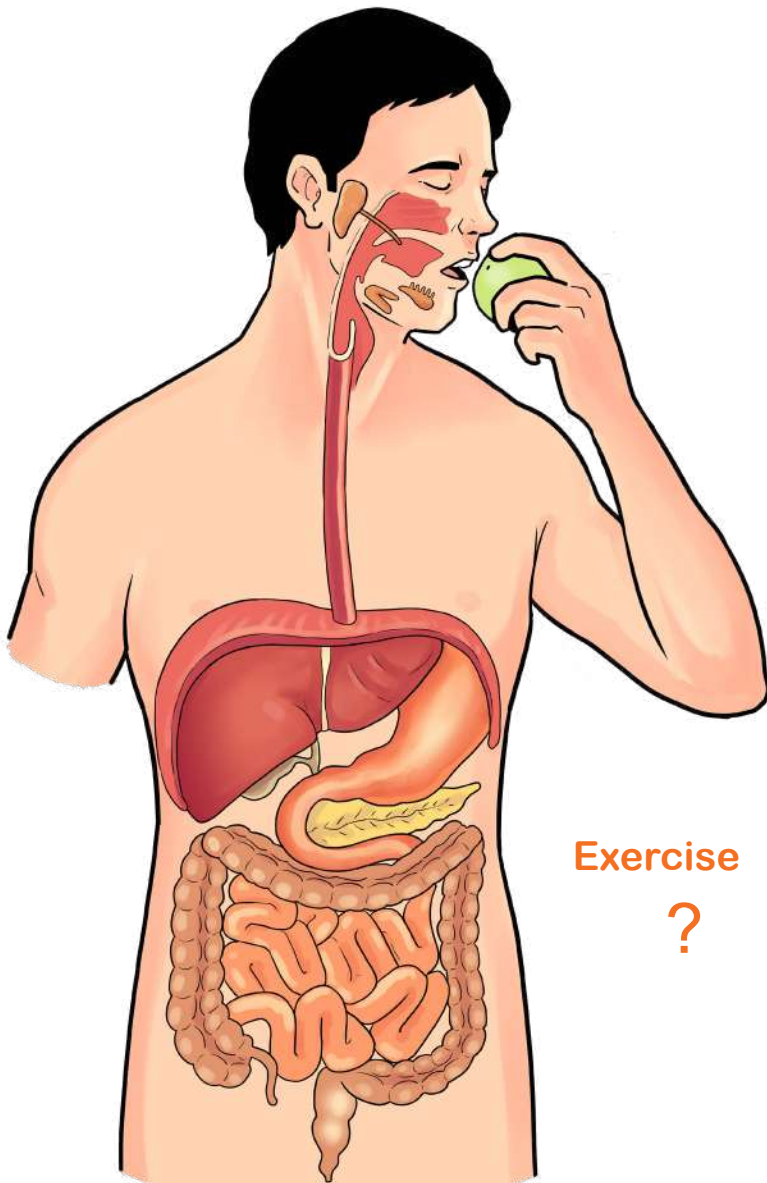

Exercise

?

1. If there were no microorganisms in the soil, would there be any problems with human nutrition or metabolism?



Chapter 14

Light

Chapter 14

Light

At the end of this chapter, students will be able to know the following:

- ✓ The colour of light
- ✓ Reflection, refraction and absorption
- ✓ How we see and the types of colour

Generally we can say that what we see with our eyes is light. However, it is not a completely scientific way of saying, because we see a lot of people, plants, sky, and clouds with our eyes – are all they light? There is no light in them. But light falls on them- so when the light from there falls on our eyes, we see them. If it becomes dark or when we close our eyes and don't let the light come into our eyes, we don't see anything.

Have you ever wondered why we see a Hibiscus flower as red and the leaves of Hibiscus flower as green? If you want to understand that, you need to know a little more about light.



The colour of light

In the meantime, you have learned that the scientist Newton had examined and shown that the colour of the sun — which is colourless or white — is actually made up of purple, blue, azure, green, yellow, orange, and red. When all of them are mixed together, it is seen as colourless or white colour in our eyes. We have seen in the rainbow that there are these seven colours in the sun's rays. In the rainbow, the sun's rays are divided into seven colours. If the CDs of songs or computer are reflected with light, seven colours are seen to have been divided there.



So when we see a hibiscus flower as red, it means that the white colour, which is a combination of all the colours, has absorbed all colours other than red after being reflected on this flower. Therefore, from there, only the red colour can come out and can come to our eyes. That's why, we see the flower as red. In the same way, we see the leaves of a tree as green because all colours other than green are absorbed, after the white colour, a combination of all colours, has been reflected on the leaves. When the dispersed green colour comes to our eyes, we see it as green.

You can check yourselves if it is really true. If you try to see the red flower in the green light, you will see the flower as pitch-black! Because after the green colour has been absorbed in the Hibiscus flower, no colour light will come out of it, so it will look black.

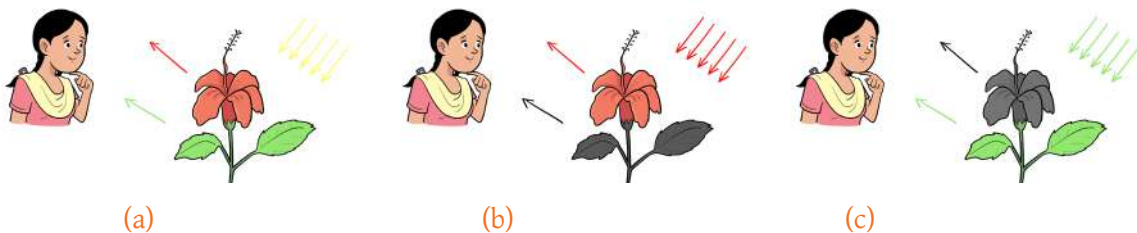

- a) In white light, colourful things can be seen in the right colour.
- b) In red light, it is not possible to see green coloured things.
- c) In green light, it is not possible to see red coloured things.

For the same reason, the green leaf will look pitch-dark in the red light.

So you can realize that the meaning of something to look black is that all colours have been absorbed there. In the same way, the meaning of something to look white means that no colour has been absorbed there! If you let a black cloth and a white cloth dry in the sun, the black cloth will dry sooner, because the black colour cloth keeps all colours absorbed, and as a result, the cloth gets hotter and can dry sooner. A little while ago, you were told that if the colours of white light are divided, they are found as purple, blue, azure, green, yellow, orange and red respectively.

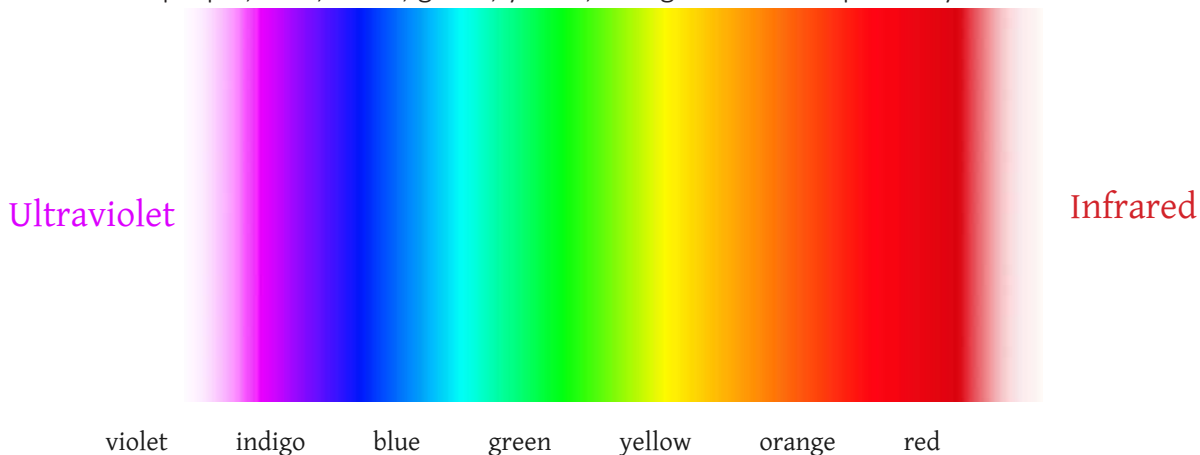

Image: Outside of visible light, there are also ultraviolet and infrared lights

Let us ask a strange question, is there any colour before purple? Again, is there any colour after red? Honestly speaking, the name of the previous colour of purple is ultraviolet and the next colour of red is infrared! However, the interesting thing is that we do not see those colours! Insects can see a little bit of ultraviolet colour. So it is seen that ultraviolet light is often used to catch insects. The infrared colour is also used in the remote control of the television. Even if you can't see that colour in your eyes, the camera of the smart phone can see that colour. So if you want, you can see the light by holding the remote control in front of the camera of a smart phone.

Light does not fade away, in spite of being ultraviolet ray on the one hand, and infrared on the other hand, rather spreads far and wide. You will be able to know about these issues in the higher class.

Reflection, refraction and absorption

If you fill a glass with water and keep it in the sun's rays coming from the window, you

will see that the sun's rays are reflected from the surface of the water on the ceiling of the house. If you observe closely, you will see that the sun's rays have refracted in and entered the glass through the water. Not only that, if you leave the glass of water in the sun for a long time, you will see that the water has warmed up a bit, which means that it has absorbed a little bit of sunlight.

The air was a medium here. The sun's rays have come into the water from that medium through another medium. Whenever light travels from one medium to another, the three processes of reflection, refraction and absorption take place. How much light is reflected out and how much is refracted in and how much is absorbed depend on the nature of the two media (singular-medium), the angle at which the light falls, and so on.

You have known a little while ago that how much colour will be absorbed depends on the colour of

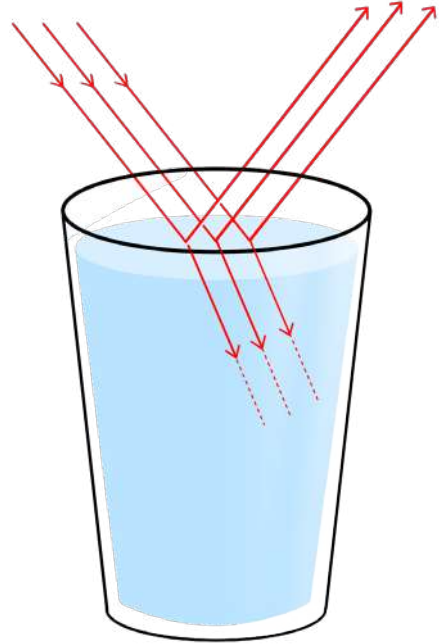

Image: Reflection, refraction and absorption of light

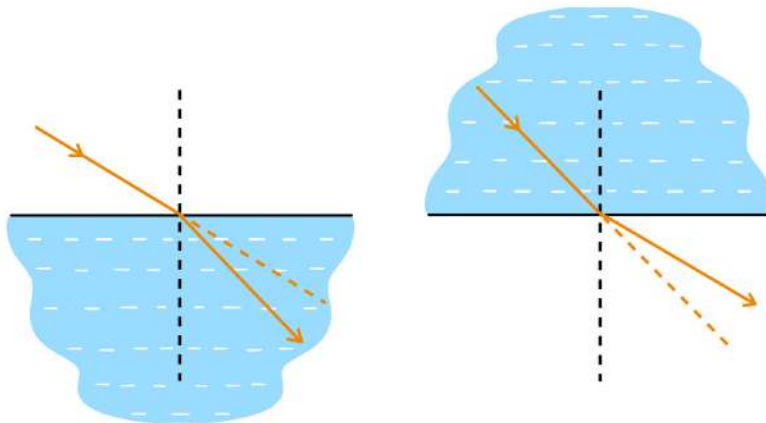

Image: Refraction of light from air to water and from water to air

a thing. Even, what appears to be transparent or colourless to the bare eye is more or less absorbed.

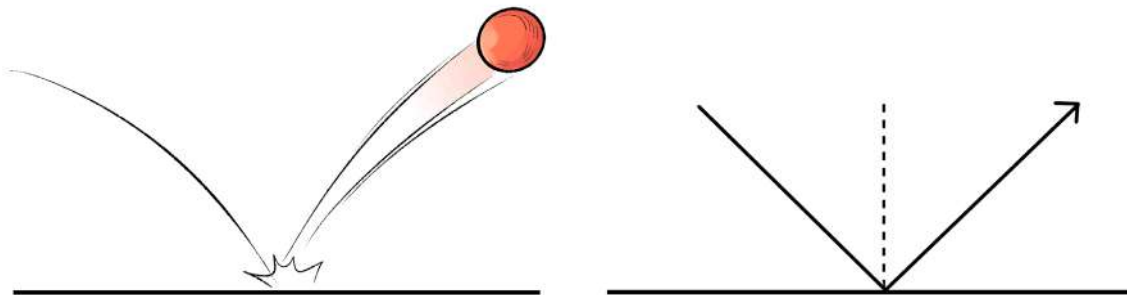

Image: The reflection of light is like a ball's getting dropped on the floor.

The reflection and refraction of light follow certain rules. When a ball is thrown on a flat floor and it runs at the same angle in the opposite direction, the same thing happens in the case of the reflection of light. When it travels from one medium to another, light is refracted to exactly the opposite direction.

The reflection of light is a very familiar thing to us. We see our face in the mirror every day! One thing we always notice when we look at ourselves in the mirror- in the reflected appearance, the right and the left sides always change. Have you ever wondered why this happens? Will you be able to create a mirror where our right and left sides do not change when we look at our appearance?

The task is not difficult. Place the two mirrors at a 90 degree angle as shown in the picture. You will see that your appearance has not changed. If you raise your right hand, the reflected appearance will also raise the right hand. Can you tell why this happens?

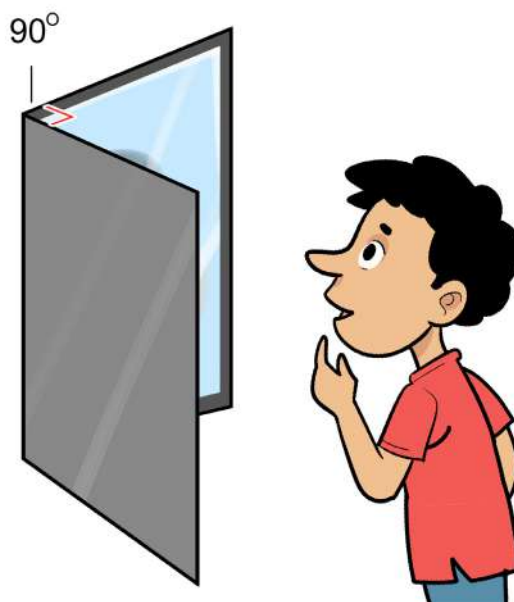

Image: The reflection in two mirrors placed at right angles does not invert right-left.

A more interesting thing happens with the refraction of light. We are always accustomed to seeing that light travels in

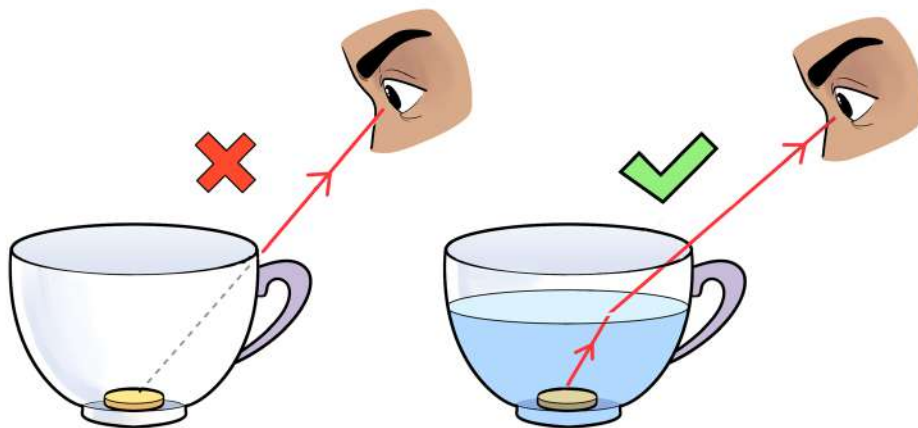

Image: The ray of light is getting curved while travelling from water to air.

a straight line. But when light tries to enter from one medium to another, it does not travel in a straight line- the light bends to enter. If it passes through light medium (air) to dense (water) medium, then the line of light will bend inwards. If the light travels from a dense medium to a light medium, it bends outwards. You can easily test that it is true. Put a coin in an empty cup so that you can see the coin. Since the light travels in a straight line, it can be said that now the coin and your eyes are in a straight line.

Now you slowly move your head back so that the coin is no longer visible. Keep pouring water in the cup. This time it will seem that the coin has come up and you can see it again. In fact, the coin is in its own place; the light is coming in a curved way so we see like that.

We also do a lot of work by using refraction. Lenses are made using the bending property of light, as it passes from air into glass. That lens is used to make a variety of practical equipment, from eyeglasses to cameras, binoculars, and microscopes.

The colour of light

You are accustomed to seeing a variety of colours in many places, from your books to televisions, smart phones and laptops. You may think that in order to create these colours, you have to use all the colours. In fact, it is not true- our eyes can see all the colours with only three colours. To test the fact, place a very fine drop of water on the screen of a smart phone by carefully shaking the wet finger. Then that water drop will act as a convex lens. You will see that with only these three colours- red, green and blue, all colours on the screen of the smart phone are created.

When colourful light enters the eyes, the sensory cells of red, blue, and green colours

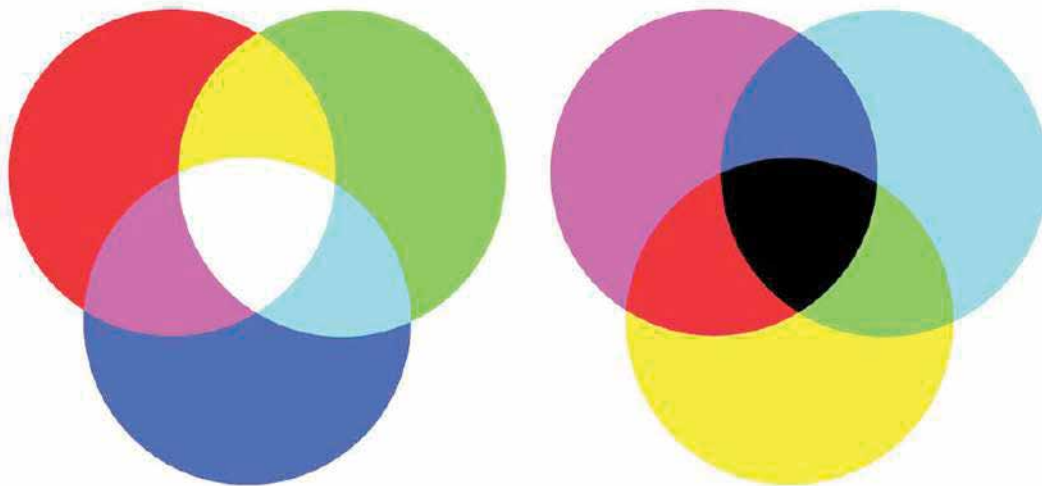

Image: The colour in the picture on the left side is made of a mixture of light of three colours, as is produced in the screens of computers, televisions or smartphones. The colour in picture on the right side is made by mixing colours with paint brush.

in the retina of the eyes produce a certain sensation of colour. The picture on the next page shows colours produced by the combination of other colours. As you see, white is made with equal amount of red, blue and green.

Here is another thing to remind you. If you mix red, blue and green colours with a paintbrush on a piece of paper, you will not find the colours shown in the picture on the left side; you will get some different colours, those colours are also shown in the second picture. Those of you who draw pictures must have noticed that yellow, red and blue can be used to make all other colours.

From the screens of smart phones, televisions and computers, a combination of red, blue and green colours comes to our eyes, and the eyes create the sensation of a certain colour for it. When colour is mixed on paper, the particles of one colour move over the particles of another colour; so, the upper particle absorbs the colour of the lower particle, and the colour that is not absorbed only comes out. Then the mixture of red, blue and green colours does not come in your eyes, the unabsorbed real colour comes and you see that colour.

Exercise



1. Why are rainbows round?
2. Why aren't the rainbows seen at noon?

THE RAINBOW

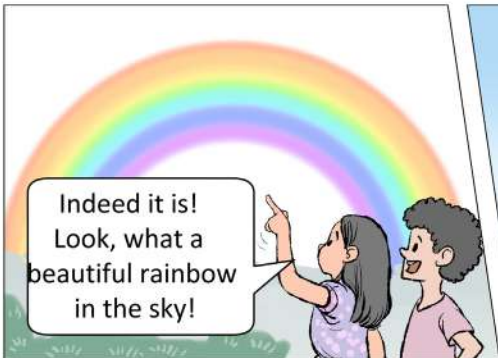

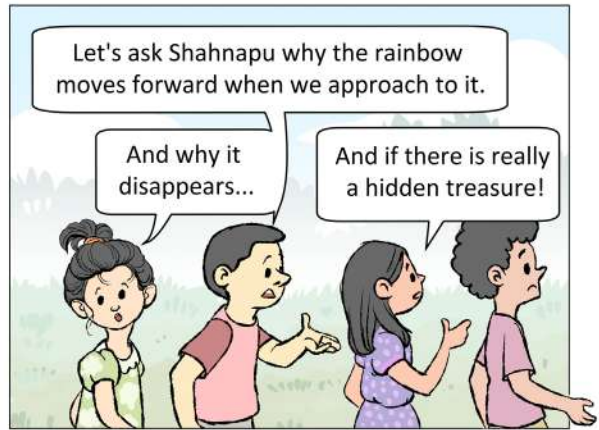

A little later



When sunlight reflects through water particles, it is divided into its seven colours. The disappears when the water particles dry out.

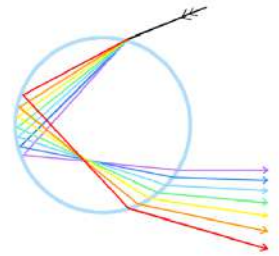

You can make your own rainbow by sprinkling water in the sunlight! There will be a rainbow against the sun!

A little later

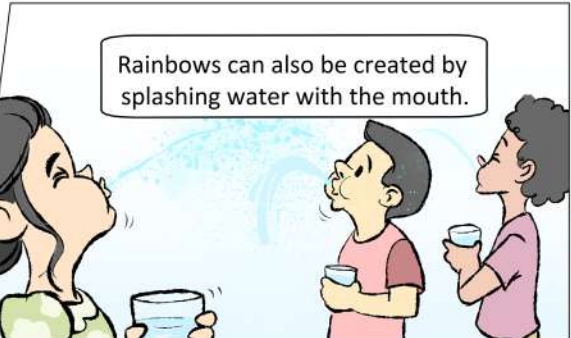

A little more later



End



Chapter 15

Environment and Topography

Chapter 15

Environment and Topography

At the end of this chapter, students will be able to know the following:

- ☑ Environment
- ☑ Elements of environment
- ☑ Landforms
- ☑ The interrelationship of soil, water, air, the living world and landforms
- ☑ Natural diversity in different parts of Bangladesh

Environment

The word environment is very familiar to us. To describe the condition of a place, we describe the environment of that place. There may be two types of environment—man-made and natural. In general, the environment is all about the organic and inorganic elements that surround us. Different elements of the environment affect people and other lives in many ways. If we feel comfortable staying or working somewhere, we say that the environment of that place is good. So in order to keep the environment of a place good, we must first know about the different elements of the environment.

Elements of environment

The main elements of the environment are soil, water, air and the living organisms. Among them, the first three elements are lifeless. This is why soil, water and air are called abiotic elements of the environment. And all living plants, animals and the whole living world are called biotic elements.

Soil

The soft part of the earth's crust is called the soil. This soil is very important for the survival of plants. The more fertile the soil, the better the crop grows on it. However, the process of soil formation is not easy. Soil is formed by mixing minerals and organic matters caused by the crushing of rocks. Minerals of soil are divided into three groups according to their sizes. These include sand, silt and clay. Because the sand particles are the largest, they cannot hold water. Again, the particles in the clay are too small, the water trapped inside their gap cannot be easily absorbed by the plant. This mixture of sand, silt and clay in different amounts results



in different types of soil. If sand, silt and clay are not predominant in any soil, then it is called loamy soil.

Soil pollution

Various man-made pollutants are the main cause of soil pollution. These polluting chemical substances can be both organic and inorganic. Different types of wastes not disposed of properly, various wastes generated from mills, and uncontrolled use of fertilizers and pesticides on agricultural land pollute the soil. Soil pollution can be a threat to the health of various organisms and humans. In order to prevent soil pollution, it is necessary to refrain from throwing garbage here and there, and also to use the right amount of fertilizers and pesticides in agricultural land in the right way.

Water

Another name for water is life. Water is essential for the survival of all living things. Very little of the world's whole water is sweet or fresh water. This water can be used for drinking and other daily activities. Most of the freshwater is in the form of ice and very little is in rivers and in the atmosphere. This amount of water in the air is called moisture. However, water or water vapour in the atmosphere is very important in determining the characteristics of the weather, even if it is small in quantity. Again, the water in rivers, canals, lakes, etc., plays a special role in changing the topography. If you notice, you will see that the silt layer falls on the soil during the flood season.

This soil is very important for crop production. Again, during the floods in many areas, the banks of the river break and many houses and lands are submerged in water. We use ground water through pumps or tube wells. Plants absorb the water that is in the middle of the pore space in soil, and survive. The importance of water as an element of the environment cannot be described in words.

Water pollution and its remedies

When water loses its natural properties in a mixture of different substances and becomes harmful to the ecosystem, we can call it polluted water. Water can be polluted as a result of various human activities. Water is polluted when stool and urine are discharged here and there, near water reservoir, fertilizers and being applied in the land are washed in water, waste of various factories and water are dumped in the river. As a result, groundwater can even be polluted.

Using or drinking contaminated water on a daily basis can lead



waste is disposed in or
pesticides after
and dumped
polluted

to physical and mental damage and even death due to the attack of various types of diseases. Therefore, in order to prevent water pollution, garbage cannot be dumped here and there. If there is a risk of rain, applying fertilizers and pesticides should be avoided.

Since the freshwater is a very small amount of earth's total water, people will face severe crises in the future if they waste water. It would be a waste to give more water than the required amount of water for the trees in the garden. We turn on the water tap a lot of the time while we take bath. As a result, a lot of water is wasted. It is possible to prevent wastage of water only by changing these behaviours.

Air

One of the elements of the environment is air. Although air is made up of a mixture of different gases, dry air consists mainly of nitrogen (78%) and oxygen (21%). However, due to the difference in humidity, water vapour can be 0 to 4 percent in the air. Moreover, air also contains very small amounts of argon, carbon dioxide, methane, ozone, hydrogen and other gases. The amount of different gases in the air can vary depending on the place and time.

From the air, we get the oxygen that we need to survive. Again, the carbon dioxide emitted during our respiration or breathing is used by plants to make food. There is also a layer of ozone gas above the Earth's atmosphere that protects the Earth from the sun's harmful ultraviolet rays. The sun's ultraviolet rays are extremely harmful to any living thing.

Air pollution

Air pollution is caused by various human activities and natural causes. As a result of burning oil, gas, wood, etc. carbon dioxide and carbon monoxide are released into the air. Carbon monoxide is a deadly toxic gas and harms the human body. Methane is released into the air as a result of the decomposition of various waste products. Methane and carbon dioxide affect the increase in average air temperature, known as the 'greenhouse effect'. If the fuel is not used properly, it emits toxic gases like carbon monoxide. In addition, chlorofluorocarbon (CFC) gas is emitted from aerosol sprays, refrigerators, etc., which depletes the ozone layer. As a result, the sun's harmful ultraviolet rays enter the earth. In addition, natural causes of air

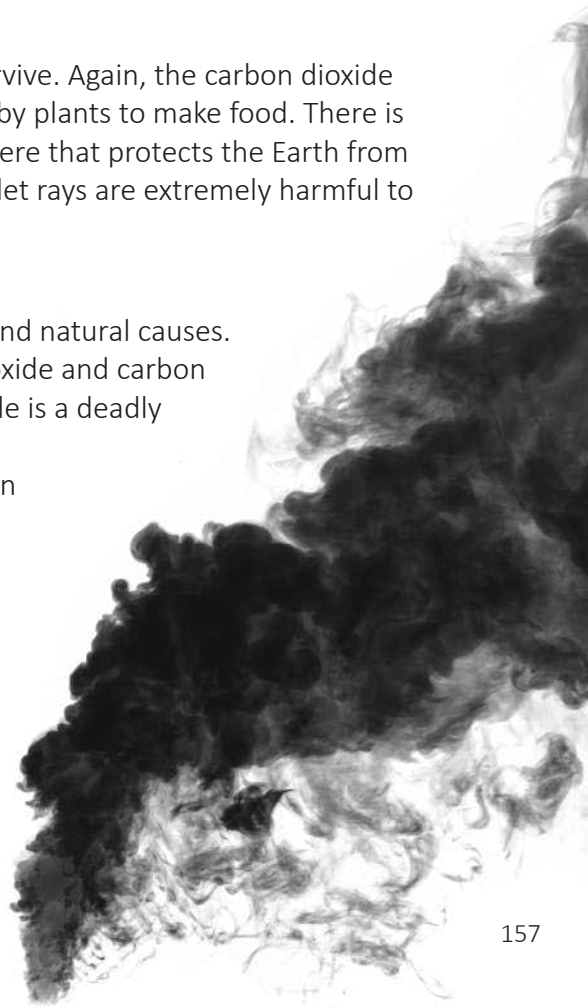

pollution include volcanic eruptions and forest fires. These two events result in the release of large amounts of polluted gases, ash particles, etc. into the air.

The first thing to do to prevent air pollution is to use fuel properly. Large quantities of gas, oil, coal, etc. are used to generate electricity. As a result, a large amount of polluted gas is released into the air. By using electricity properly without wasting, the use of fossil fuels for power generation will be reduced which will help in preventing air pollution. The production and use of products that emit CFC should be stopped. The burning of garbage should be stopped. In addition, if the soil is covered with grass and trees, the amount of dust in the air will be reduced.



The living world

Due to the fact that the environment of the earth is suitable for sustaining life, various kinds of plants and animals have developed here. Life has existed on earth for about three and a half billion (350 crores) years. From the deepest part of the ocean to the highest point of the atmosphere, from the deep forest to the top of the high mountains, the living world is extended. In terms of size, the living world range from unicellular bacteria to giant blue whales. There are many microscopic organisms in the air. The soil contains plants, various insects, earthworms, and many other animals. There are many aquatic animals and plants in the water. Phytoplankton and algae are the major sources of oxygen in the Earth's atmosphere. The various living organisms of the earth are interconnected for survival. Again, as a result of various activities of plants and animals, the topography changes. Plants can affect the weather and climate of a place. Where there is more vegetation or tree, the climate is relatively cold and rainfall is high.

Landform

Landform means the structural shape of a place. That is, the heights, shapes, slopes, relief, shapes, etc. of different lands located around the world are called landforms. There are various natural processes in the formation of landforms, among which are volcanic eruptions, earthquakes, exposure to sun rays, rivers, ocean currents, windstorm, glaciers, etc. The landforms can be divided into three main parts; Such as mountains, plateaus and plains.

In areas where it is very cold, that is, snow falls almost all the year round, the landform is formed and changed by the flow of snow. It is called glacier. It can be compared with the flow of river water. However, glacier ice flows much slower than river water.

In warmer and arid regions, landforms change as a result of wind movement. For example, dunes of various shapes and sizes can be seen as a result of wind flow in the

desert. If dust and sand are moved from one place to another as a result of wind flow, the previous place may be lowered. Again, where the transferred sand accumulates as a result of that wind, landforms can be seen as dunes. However, according to Bangladesh, different types of landforms can be seen in riverine countries mainly due to tide of rivers. In these countries, fertile plain lands are formed by the accumulation of sediment carried by the river water during floods. When the river flows over the land and falls into the sea, the soil particles (sand, mud, etc.) of different sizes floating in the river water accumulate there, Chars and islands are created.

The interrelationship of soil, water, air, the living world and landforms

Soil, water, air and the living world are all related to each other. These four elements of the environment play an important role in creating and changing the topography of the earth. There are three main processes involved in formation of landforms in any place.

1. Erosion
2. Transportation
3. Deposition

Water and air act as mediators in the formation of landforms. In this case, both liquid water and ice play a role in landforms. When rocks, soil, sand, etc. of any place are eroded by water, wind or ice, different types of landforms are formed there. When these eroded rocks and soils accumulate elsewhere, various types of landforms are formed there as well. We have earlier seen that rocks are crushed and turned into soil. Hard rocks are not easily eroded. Erosive topography is more prevalent in areas where rocks are relatively soft. During floods, many rivers erode their banks and their banks become steep. It is a landform caused by erosion. Again, in winter or in dry season, Chars are seen in the river. These are the landforms caused by sedimentation. Different animals live by making holes into the ground. These holes accelerate soil erosion. On the other hand, the covering by plants on the soil prevents the erosion of the soil in that place.



Topography of Bangladesh

In addition to the major rivers like Padma-Meghna-Jamuna, hundreds more rivers have flowed. During the floods, the sediments have accumulated in about three-fourths of the area of Bangladesh, creating vast plain lands. The average height of these plain lands is below 10 metres from the sea level. Most areas of the country are inundated every year as a result of heavy monsoon rains since the areas are not much higher than the sea level. From a modern point of view, the topography of Bangladesh can be clearly divided into three parts, namely: a) hill tracts b) terraced region and c) flood plain.

(a) Hill Tracts: They consist of hilly areas of Rangamati, Bandarban, Khagrachhari, Chittogram, Sylhet, Moulvibazar and Habiganj districts. Their average height is about 600 metres. These mountains were formed when the Himalayas rose about 25 million (2.5 crore) years ago.

(b) Terraced region: It is estimated that this terrace was formed about 2.5 million (25 lakh) years ago due to flooding in interglacial water (আন্তববরফগলা পানি). These are divided into three areas namely Barind Bhumi, Madhupur and Bhawal Garh, and Lalmai Hills. From the sea level, the average height of these area is 15 metres.

(c) Flood plains: About 80% of the land of Bangladesh except hilly and terrace region consists of river basin areas and extended plain land. These lands have been created slowly over the last 2 million (20 lakh) years. The flood plain is formed by the accumulation of soil carried away by floods year after year. Here the soil layer is very deep and very fertile.

Natural diversity in different parts of Bangladesh

The characteristics of a place are formed by the combination of different natural elements such as topography, climate, rivers and canals, forests, hills, mountains, biodiversity etc. Nature, and the plants and animals that live in it create the natural environment of a particular place. All the features that can be noticed in the natural environment of a place are the natural features of that area. For example, the natural features of Sylhet are the hills and Tilas of different sizes and there is a lot of rainfall. In the Sundarbans, various plants have pneumatophore, and twice a day, pneumatophores of the plants are submerged in tidal water. The soils of Barind land are red in colour. All these are natural features of those areas. The natural environment of a particular place depends on the topography and climate of that place.



The land area of Bangladesh is about 1,48,460 sq km. Although small in size, Bangladesh does not have shortage of natural diversity. The river basin area of Bangladesh is the largest delta island in the world and it is full of various types of natural diversity. Bangladesh can be divided into several regions based on topography. The elements of the environment, plants and animals of these regions all have special features. These areas include numerous rivers, the Bay of Bengal in the south, Haors and wetlands in the Sylhet Mymensingh areas. Most of the plain land is occupied by Padma Meghna Jamuna floodplain, Barind land, Madhupur and Bhawal terraced land, hills of Chottogram, Chottogram Hill Tracts, coastal mangrove forest of the Sundarbans, coral island of St. Martin etc. Some of these characteristic areas are discussed below.

The Sundarbans

Mangrove forests are a collection of trees and shrubs found in coastal tidal areas. Recognized as a UNESCO World Heritage Site as the largest mangrove forest in the coastal saline environment, the Sundarbans is the largest running forest in the world.



Sixty per cent of the Sundarbans, which covers an area of about 10 thousand sq km, is in Bangladesh and the rest is in India. The Sundarbans is entangled like a net with numerous rivers, mud Chars and small islands with salinity of mangrove forests. The most common tree species in this forest are Sundari and Gewa. The Sundarbans is home to about 500 (types of) wild animals, including numerous birds, fish, mammals, reptiles and amphibians. Not only fish and trees, a lot of honey is collected by the beekeepers (Mouala) from the Sundarbans every year.

Rivers

Bangladesh is a riverine country. Numerous small and large rivers have flowed over Bangladesh and later fell into the Bay of Bengal in the southern part of the country. Many



islands have been formed in the Bay of Bengal due to the accumulation of silt, sand, etc. carried by these rivers and it is still happening. All these are part of the natural diversity of Bangladesh. Apart from major rivers, rivers can be termed as tributaries according to their structure. For example, rivers that originate from another river are called tributaries. For example, Dhaleshwari is the main tributary of the Jamuna. Also Madhumati, Mathabhanga, Kapataksh river, Pashur river, Betna river etc. are tributaries of Padma. Rivers that originate from one source and flow over a certain distance to fall into another river are called tributaries of that river. In Bangladesh, rivers like Teesta, Dharla, Karateya, Atrai, Subarnashree, etc. flow from the source and merge into the river Jamuna; so, they are tributaries of the river Jamuna. In this country, about 230 rivers, including tributaries, have flowed through the country occupying an area of 24,140 km with huge amount of water throughout the year. Most parts of Bangladesh have been formed by sedimentation flowing through hundreds of rivers. These rivers are an integral part of the way of life of the people of Bangladesh; innumerable people live on the banks of the rivers, irrigation is done in agriculture from rivers, fishermen live by fishing. The people of our country regularly travel by boats, launches and ships for transportation. You will be happy to hear that considering the immense importance for the country, the river has been given the status of equal rights of living people in this country.

The Sea

The only sea in Bangladesh is the Bay of Bengal. The Bay of Bengal is a bay because it is surrounded on three sides by land. The impact of the Bay of Bengal on the climate



of Bangladesh is immense. The source of the water that we see raining from the sky is any sea or ocean. In the case of Bangladesh, during the monsoon season, there is a lot of rainfall due to the effect of monsoon winds with water vapour coming from the Bay of Bengal. At that time, monsoon winds blow from the south west of Bangladesh. Large vessels or boats can enter the rivers of the tidal areas at high tide due to the difference in water level between high and low tide. All the ships that come to the port of Mongla in Khulna enter the river at high tide from the Bay of Bengal. A large number of coastal fishermen fish in the sea to meet the demand of fish in our country. It is assumed that there is a huge reserve of gas and oil under the sea, and coastal towns are beginning to develop as tourist destinations for the people of this country.

Haor

Due to the arrival of monsoon winds, a large part of the floodplain of Bangladesh is submerged under water for four to six months. Such wetlands include Haor, Baor, Beel etc.

Haor is a low-lying area in the shape of a saucer. In the rainy season, Haors contain a plenty of water, but in winter the amount of water shrinks a lot. Haors are found in greater Sylhet and Mymensingh areas of Bangladesh. These Haors mainly get the water flows from rivers and canals. In the winter, the Haors take the form of vast, extended green lands, while in the rainy season, they take the form of shoreless seas. During the monsoon season, the area is submerged in flood waters up to 6 metres deep. Most of the water goes away during the dry season. Then in the shallow water of a Beel, a large variety of aquatic plants germinate. When the Char is visible, the bushes of Hogla and reed also develop. As a result, Haor areas have become ideal place of food and shelter for fish and other aquatic animals on the one hand, and attractive habitats for migratory birds on the other hand.

Coral

Island

St. Martin is a coral island situated in the Bay of Bengal in the south most area of Bangladesh. Coral is a type of marine insect whose dead bodies accumulate and take on different

shapes. These accumulated marine carcasses or dead bodies form coral island. Various species of fish, jellyfish and turtles can be seen in the sea water around St. Martin's Island.

Exercise



1. You have known that the topography of Bangladesh is divided into three parts. In which part is your area included?
2. What are the most familiar wild animals in your area? For what features of the environment have they chosen this area?





Chapter 16

**The interdependence of
the organisms and the
sustainable environment**

Chapter 16

The interdependence of the organisms and the sustainable environment

At the end of this chapter, students will be able to know the following:

- ☑ The interdependence of animals and plants, and microorganisms in the environment
- ☑ Use and usefulness of microorganisms in human life
- ☑ Global warming and the crisis of the living world
- ☑ Changing environment of Bangladesh and its impact on biodiversity

With the bare eyes, we usually differentiate between living and non-living things. But, if we think a little, we understand that it is not so simple. Simply we call them living beings that can move and take food. Again, if you notice their structure, you will see that they are made up of different inorganic molecules, that is, non-living matter! In addition, the definition of a living thing is not always so clear. For example, let's consider

virus. It is very difficult to categorize virus in living organism or in non-living organism as, until it reaches the host body, it is more appropriate to call the virus non-living based on the behaviour of the virus. There is no end to the curiosity of humans as to how innumerable non-living elements combine to reveal the characteristics of an organism. So scientists have been researching this for a long time. You will be able to know a lot more details about these issues in the upper class!

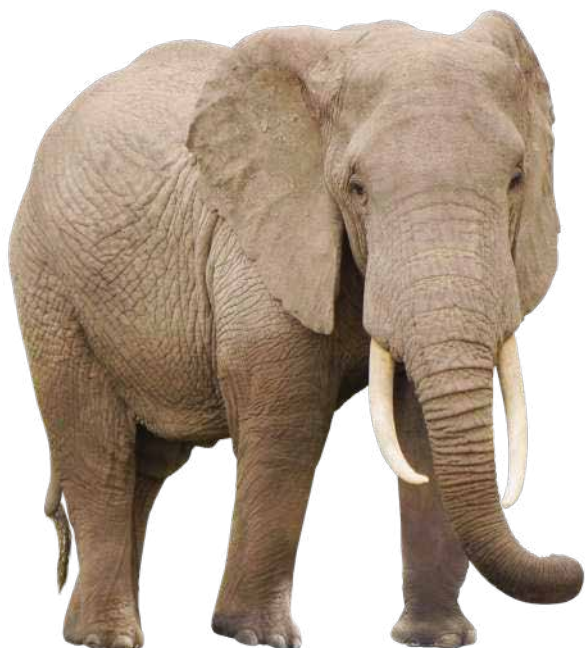

The relationship between the living world and the non-living elements is like a cycle. When a new organism is born, both organic and inorganic materials are stored in the organism's body



from various sources of the environment. When this organism dies, those organic and inorganic elements return to the environment. They continue to exist in the environment as organic and non-living material until they are later stored in an organism. An ecosystem is a system that develops on the basis of the interrelationships between the organisms of a region and all the non-living elements of their environment. Ecosystem is usually region-based. From the above discussion, we can easily understand that every ecosystem has two types of elements-organic elements and non-living elements.

Among the living elements are various microorganisms, plants and animals. Non-living elements include temperature, light, water, oxygen, soil, etc.



The interdependence of the living world

The microorganisms, plants and animals of this living world all depend on each other. At the very first, we may think of microorganisms that they only harm us by causing various diseases. But there are many microorganisms that benefit us. For example, the bacteria that we eat with yogurt are good for our body. Some fungi are the source of our life-saving antibiotics. We use

the virus to make vaccines against many deadly diseases. For example, you may have heard of the disease, Polio. This disease damages our nervous system. As a result, we become paralyzed. Vaccines against this disease are made using viruses.

Microorganisms are also important for plants. There is a type of bacteria that helps plants absorb nitrogen from the environment. Scientists have also found a variety of microorganisms in jute leaves and stems that contribute to the growth and survival of jute.

The whole living world depends on plants. Because we know that all green plants use sunlight to produce carbohydrate. The energy stored in the carbohydrate is then passed on to other organic molecules. In this way, the light energy coming from the sun spreads to other living things in different forms. Microorganisms receive nutrients from both plants and animals. In addition, after the death of plants and animals, they decompose them and return various elements to nature.

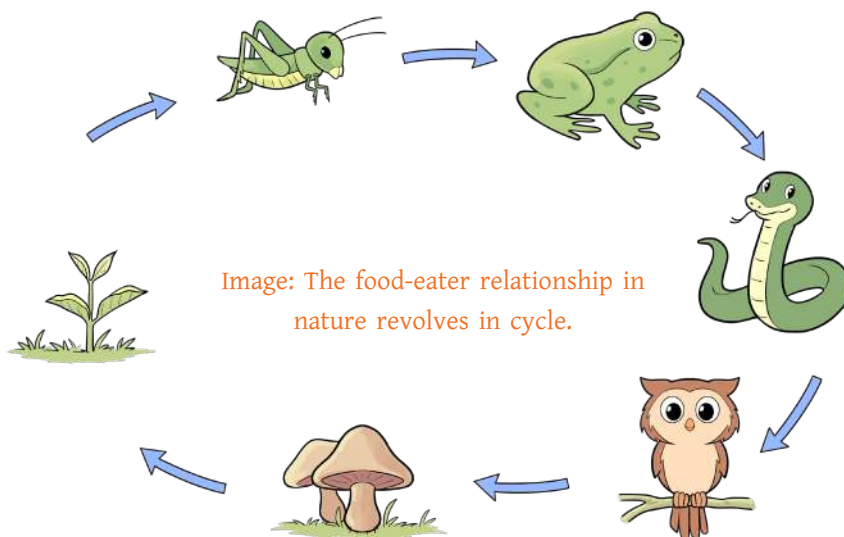

This interdependence of nutrients among plants, animals and microorganisms in nature is called the food cycle. The main point of this cycle is that one organism exists in nature as food for another organism.

The position of human beings in the food cycle of the earth is at the very top and their eating habits and related activities have a great impact on other organisms in the environment.

The role of humans in the world's ecosystem

The role of humans in the ecosystem of the world is extremely important. Since humans are the eaters of the highest level and influencers of the food cycle, their behaviour affects all in the living world. Humans have an effect on not only living

things but also non-living things. People are now affecting various elements of environment and weather including fire, water, and air. They are industrializing agriculture and making various vehicles, roads, solar panels etc. for transportation. This is having a long lasting and widespread impact on the environment. For example, when we turn small and big hills, wetlands, etc. into a plain land to make an agricultural farm, we largely change the ecosystem of that place. Sometimes, we even move an ecosystem from its original foundation to a completely different place. When we cut down trees of a forest, the ecosystem there is changed. This is because forest-dependent species have to make new efforts to survive, and both local humidity and climate change. Again, the construction of a dam also changes the course of the river and the distribution of water, and affects the species living along the course of the river.

This is how various activities of human beings affect our environment, so at this moment the major responsibility of human beings is to protect this environment.

The environment is protected in two ways. One way is to use natural resources in such a way that there is no shortage of those resources for future generations to use. For example, now a farmer is cultivating his land and producing crops. As a result, the fertility of the land is gradually declining. If he cultivates in such a way that the fertility of the land is restored as before, and his descendants can cultivate in the future just like him, then the soil or environment of the land is being preserved. In special cases, when a natural resource is on the verge of extinction, it is important to protect it with utmost importance. In this case, any living thing or natural resource is preserved as it is, and people are prevented from using it. There are many plants and

animals that are used by humans to make food and medicine. If their number is greatly reduced then they have to be protected in this way. In that case, no one will be able to use those plants, animals or natural resources and they will have to be preserved as they are.



Image: Waste management becomes easier if waste is segregated according to the types like biodegradable, non-biodegradable, hazardous, e-waste etc. For this reason, different coloured dustbins are kept for throwing specific types of wastes in different places including hospitals.

Waste management

Unwanted or unusable items are called wastes. When an object is no longer usable, rather occupies space, and in many cases can be harmful to humans or other animals, it is considered waste. For example, we use glass, ceramic or melamine dishes,

bowls, glasses at home. If they break down, they turn into waste. These are solid wastes. If various electronic appliances used in the house are damaged and unable to be repaired, then they turn into electronic or e-waste. The unusable portions which are thrown after the cutting of vegetables for cooking is also waste. However, they are decomposable and organic manure can be produced by decomposing them. The gauzes, bandages used in hospitals, and various body parts are discarded after surgery, and various types of harmful organics are produced. These are called medical wastes and are one of the most harmful wastes. The packets that we throw after eating chocolates, biscuits and chips are not decomposable and are very harmful for the environment. Therefore, these should not be thrown here and there.

Waste management is the method of arranging these according to the types of wastes. Compost manure can be prepared by decomposing such decomposable wastes and this compost manure is used in agriculture. Reusable new products can be made by melting or processing glass or metal wastes. There are some wastes that cannot be recycled and reused by humans. In that case, they are destroyed or kept under the ground in such a way that it cannot be harmful to anyone. However, in the case of waste management, the first thing to follow is to dispose of the waste in a specific place, instead of disposing here and there.

Preventing the waste of resources and sustainable use

In many cases, the resources that we use for our daily life are limited. Therefore, in order to keep the resources usable for a long time, it is necessary to prevent the waste of resources and use them properly. Among the resources that we use are water, different types of fuels and food.

Soil is a resource without which we would not be able to produce our agricultural products. Soil is also a limited resource. If the same crop is cultivated in a land for several years in a row, the fertility of that land decreases. This is because certain type of crop requires certain type of minerals of soil. Minerals take time to return naturally to their previous state in the soil. If the same type of crop is cultivated continuously, the soil fertility will not have time to return to its previous state. As a result, crop production also decreases. Even, if there is no cover of grass or other trees on the unused land, the fertile top soil of the upper layer is eroded and the fertility of the land is reduced. Water is a big part of the body of different organisms. Without water, plants and animals will not be able to survive. We can use a very small part of the vast water body of the world directly.





Image: Solar energy is a major source of renewable energy that can be used to generate electricity to meet the demand for electricity to a large extent.

But due to our ignorance, a lot of water is wasted and, as a result, we may be deprived of water when we need it. We should use only the amount of water that we need in our daily work. The right amount of water should be used for bathing, car washing, watering the garden or land, and for using the bathroom. We produce energy by using different types of fossil fuels. Fossil fuels include wood, coal, fuel oil, natural gas, etc. Once these fuels are used, there is no way to reuse them. This is why, they are called non-renewable fuels. Therefore, waste should be avoided in the use of these fuels. However, wind energy, solar energy, etc. are useful for repeated use and these are

called renewable energy. Increasing the use of renewable energy can reduce the use of various fossil fuels.

Any living thing needs food along with water to survive. In many parts of the world, people cannot afford to eat three meals a day. Other resources, including fuel, are used to produce food. Soil fertility is used to grow crops, fossil fuels or electricity is used for irrigation and food processing. Fossil fuels are often used to transport crops or other foodstuff. So, wasting food means wasting other resources as well. Only if we can stop wasting all kinds of resources, we will be able to build a happy, prosperous Bangladesh.



Image: Another source of renewable energy is wind power. In many countries around the world, electricity is generated by using wind power with the help of wind turbines.

Climate crisis in Bangladesh and what we need to do

The impact of global climate change has also fallen on our country Bangladesh. If we talk to our grandparents, we can understand that as a country of six seasons, they could understand the difference among the six seasons. Farmers depended on climate and seasonal changes for the country's agriculture. But now there are some exceptions to that rule of changing seasons. For example, Ashar and Shraavan in the Bangla calendar, these two months are referred to as the rainy season, but now there is a lot of rain in the month of Ashwin, which brings untimely floods. Again, it is not as cold as it used to be earlier in winter. As a result of these changes in weather and climate, the incidence of cyclones, floods, drought, etc. has increased in the country.

A big cyclone named 'Sidr' hit Bangladesh on 11 November 2007. At that time, the salt water of the sea flooded the agricultural lands and human habitation. Since then, crop lands, ponds, habitats, etc. in the southern part of Bangladesh have been affected due to salinity. Agricultural production has declined. Scientists fear that this trend will continue. Many coastal areas of Bangladesh might be permanently submerged under water. Even a part of the Sundarbans can be affected by permanent flooding and bring about a huge change in the living world here.

As we are facing salinity in the southern areas, droughts are increasing in our northern areas due to shortage of rain. As a result, agricultural production will decrease here and biodiversity will change. Many species of plants and animals in Bangladesh have already become extinct.

Among the mammals, Dorokata hyena in Rajshahi region, gray wolf in Noakhali and Chottogram, Nilgai in Dinajpur-Panchagarh area, bunting or gaur (Bongoru in Bangla) in





Image: Sumatran rhinoceros, once found in Bangladesh. They are now endangered all over the world.



Image: Nilgai which once roamed around Dinajpur-Panchagarh areas



Image: Striped hyena, once found in Rajshahi region

Chottogram and Sylhet have become extinct. Once upon a time, wild buffalo was found in all forests of the country. Besides, there were three types of rhinoceros in Bangladesh: Sumatra rhinoceros, Java rhinoceros and Indian rhinoceros. Bada or swamp deer is locally called twelve-horned deer which was found in Sylhet and Haor areas. An animal called black bull (Krishna Shar) could be found in Rajshahi and Dinajpur areas. All of them are now extinct. Bangladesh is said to be one of the top countries in the world to be affected by climate change. The issue of climate change is a global crisis. This climate change has happened and is still happening now due to industrial and technological reasons of the developed countries of the world. But we have to work



for the preservation of the environment from personal, family and social levels wherever we are. A very important thing is to take care of our own behaviour. We can contribute to the world by not wasting the resources of the world. We can reduce the use of polythene and plastic products. We can personally reduce wasting water; we can reduce wasting gas.

We need to remember that the world does not belong to us only. We humans are just a species. There are millions of other unknown species here. The presence of all of them is essential for the balance of our world. But at this time various human activities are having a negative effect on all living and non-living worlds. We all have a responsibility to protect the world from these destructive consequences and to make this beautiful world livable for all through every action of ours.

Exercise



1. Think about what can be done to prevent the waste of resources in your home?
2. Can you find out the endangered plants or animals in your area? Think about what can be done to prevent their extinction.



করোনাভাইরাসের (কোভিড-১৯) প্রাদুর্ভাব রোধে জনসচেতনতা মূলক তথ্যাবলি

করোনাভাইরাস সংক্রমণের ঝুঁকি রোধে করণীয়



১ ঘন ঘন দুই হাত সাবান পানি দিয়ে কমপক্ষে ২০ সেকেন্ড যাবৎ পরিষ্কার করুন। প্রয়োজনে হ্যান্ড স্যানিটাইজার ব্যবহার করতে পারেন।



২ যেখানে সেখানে কফ ও থুতু ফেলবেন না। হাত দিয়ে নাক, মুখ ও চোখ স্পর্শ থেকে বিরত থাকুন।



৩ শ্বাসকষ্ট

করোনাভাইরাস (কোভিড-১৯)
এর লক্ষণসমূহ

৪ হাঁচি-কাশির সময়ে টিস্যু অথবা কাপড় দিয়ে বা বাহুর ভাঁজে নাক-মুখ ঢেকে ফেলুন। ব্যবহৃত টিস্যু ঢাকনামুক্ত ময়লার পাত্রে ফেলুন ও হাত পরিষ্কার করুন।



Academic Year 2023

Class Six Science

সমৃদ্ধ বাংলাদেশ গড়ে তোলার জন্য যোগ্যতা অর্জন কর
– মাননীয় প্রধানমন্ত্রী শেখ হাসিনা

মিতব্যয়ী হওয়া ভালো

তথ্য, সেবা ও সামাজিক সমস্যা প্রতিকারের জন্য '৩৩৩' কলসেন্টারে ফোন করুন

নারী ও শিশু নির্যাতনের ঘটনা ঘটলে প্রতিকার ও প্রতিরোধের জন্য ন্যাশনাল হেল্পলাইন সেন্টারে
১০৯ নম্বর-এ (টোল ফ্রি, ২৪ ঘণ্টা সার্ভিস) ফোন করুন



Ministry of Education

For free distribution by the Government of the People's Republic of Bangladesh.